

Minimization of power consumption for the monitoring of mobile-WiMAX service coverage in DBDM Handsets

Changmin Lee and Youngcheol Park

Department of Electronics and Information Engineering, Hankuk University of Foreign Studies,
Yongin-si, Kyungi-do, South Korea 449-791
E-mail: trugntlmrio@hufs.ac.kr, ycpark@hufs.ac.kr

Abstract This paper presents a wideband active detector to scan the mobile WiMAX(mWiMAX) service area when a mWiMAX+cellular DBDM terminal is out of the mWiMAX coverage. The device, which consists of a wideband LNA and an envelope detector to minimize the power consumption for the scanning of signal existence, is designed to detect 10MHz of mWiMAX signal at 2.35GHz with the gain of 10~11dB. Measurement result shows 30~60mW of power consumption over the input power of -50 dBm~ 0 dBm, which is significantly lower power consumption compared to the case of conventional reception with full demodulation of mWiMAX signal.

1. Introduction

For Korean and North American markets, dual-band dual-mode (DBDM) terminals supporting mWiMAX and CDMA cellular network are being deployed by various market leaders. However, due to the limited coverage of mWiMAX system, cellular modem periodically asks the mWiMAX modem to check the coverage of mWiMAX system unless it has registered to the network and go into the power-save mode[1]. The diagram of DBDM cell coverage is shown in Fig.1. The regular power-save-mode operation is designed to minimize the power consumption of the modem although it is only supported within the mWiMAX coverage of I and III. In the contrary, when the terminal is out of the mWiMAX area such as in II, the mWiMAX modem is periodically awakened by the cellular modem and performs full demodulation to check the existence of the mWiMAX signal, which generally takes hundreds of milliwatts for several hundred milliseconds. The block diagram of DBDM terminal is shown in Fig.2. As a result, the average power consumption for the mWiMAX coverage checking is the dominant factor of the power leakage estimation when the terminal is out of the mWiMAX area. Thus, in this paper, a wideband detector with active gain is suggested as a supplementary device to pre-scan the mWiMAX cell coverage for the minimized power consumption. When the output of the detector indicates the existence of any signal, the mWiMAX modem wakes up and proceed for the full reception of the signal through the registration to the network. By adopting this pre-scanning process, the power consumption for the site searching can be dramatically reduced compared to the full wake-up of the modem just for the coverage check.

2. Power consumption on mWiMAX Block

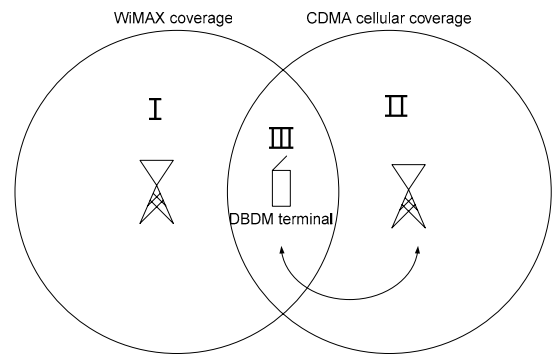

Figure 1. Diagram of DBDM cell coverage.

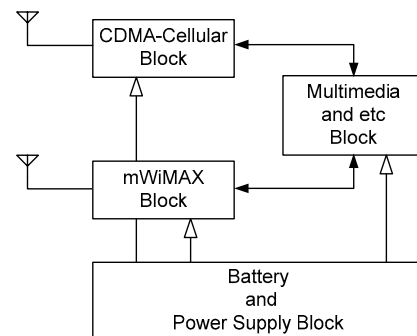

Figure 2. Block diagram of DBDM terminal.

When a DBDM terminal is in area II, the mWiMAX block is awakened by the cellular modem to check the existence of the mWiMAX signal. The basic UL parameters for mWiMAX handsets are presented in Table 1. Thus, the power consumption for the monitoring the DL signal can be calculated based on the TDD nature of the signal.

Table 1. Basic UL parameters for mWiMAX handsets[2].

Parameters	Values
Nominal bandwidth	8.75MHz
FFT size	1024
OFDMA symble time	102.4μs
TDD frame length	5ms
Number of symbles/frame	42 = 27(DL) + 15(UL)
TTG+RTG	161.6μs = 87.2+74.4

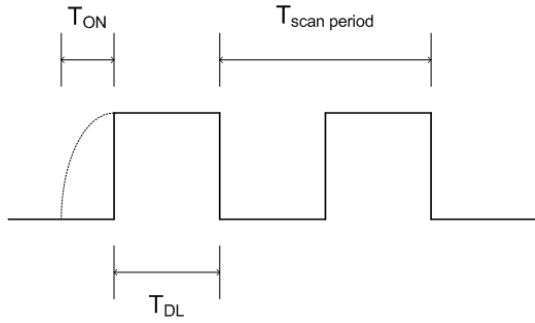

Figure 3. Period of monitoring WiMAX service coverage.

When the mWiMAX modem is assumed to receive about 5 frame-signal and consume about 600mW (330mA * 1.8V), the stand-by average power is calculated as below,

$$P_{avg} = P_{modem,ON} \times (T_{DL} + T_{ON}) / T_{scan\ period} \quad (1)$$

$P_{modem,ON}$ means the power consumption when modem is proceed for the reception. T_{DL} , T_{ON} , $T_{scan\ period}$ signify the DL time, boot-up time for turning the modem on and the scanning period of mWiMAX signal respectively. The period of monitoring WiMAX service coverage is shown in Fig.3. As a result, the average power consumption to detect the area of mWiMAX when the terminal is out of the mWiMAX area is about 31mW(in the case of $T_{DL} = 15.55ms$, $T_{ON} = 500ms$, $T_{scan\ period} = 10sec$) by the general mWiMAX modem operation, which means that the current of 11.7mA is constantly consumed with 4.2V battery.

$$\begin{aligned} T_{DL} &= 5 \times (5ms - RTG - TTG) \times \frac{27}{42} \\ &= 5 \times (5ms - 0.161ms) \times \frac{27}{42} \\ &= 5 \times 3.1ms \\ &= 15.55ms \end{aligned} \quad (2)$$

3. Design of LNA and Envelope Detector

3.1 Design of wideband LNA

The schematic diagram of the wideband LNA circuit is shown in Fig. 4. For the verification of the idea, the discrete pHEMT transistor ATF-34143 from Avago Technology is used[3], which is used up to 6GHz frequency range. The LNA is optimally designed for the wideband signal reception at 2.35GHz considering WiMAX signal[4]. The amplifier uses a high-pass network consists of a series capacitor and a shunt inductor. This topology is especially well suited for wideband applications such as OFDM [5].

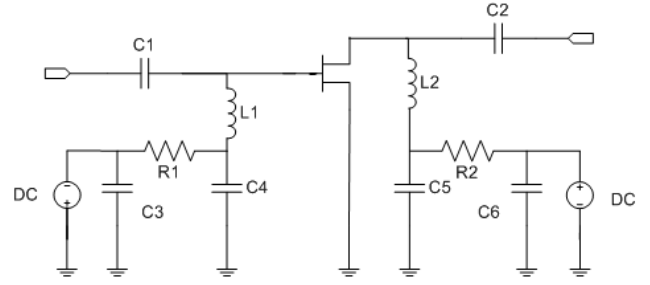

Figure 4. Schematic diagram of wideband LNA circuit.

Also, the transistor is biased at V_{ds} of 3 volts with 10mA and 20mA drain currents. Accordingly, the LNA consumed DC power of 30mW and 60mW, obtaining gain of 11dB at 2.35GHz frequency. The amplifier scattering parameter is shown in Fig.5 and Fig.6.

Figure 5. S_{21} for LNA at $V_{ds} = 3V$ and $I_{ds} = 10mA$.

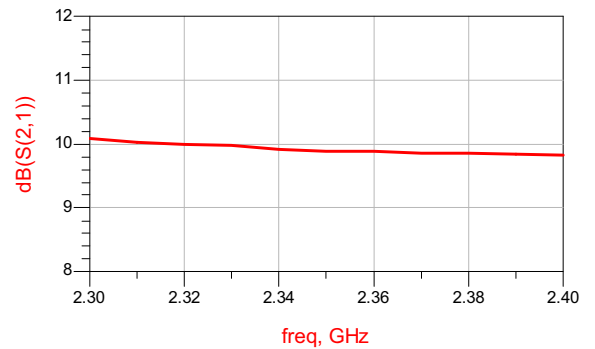
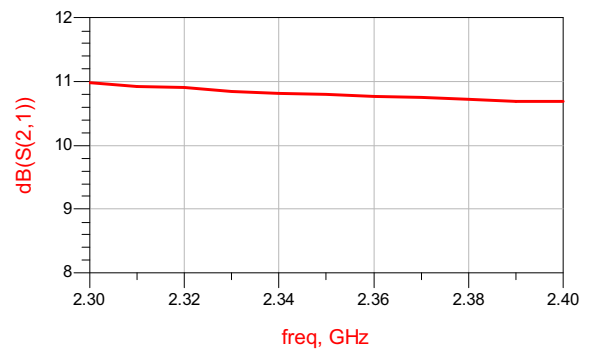

Figure 6. S_{21} for LNA at $V_{ds} = 3V$ and $I_{ds} = 20mA$.



It's confirmed that almost constant gain(10~11dB) was achieved with the two bias conditions.

3.2 Design of Envelope Detector

The implemented schematic diagram of envelope detector circuit is shown in Fig.7. The diode used in envelope detector is the Avago's HSMS-285x family. and this Schottky detector diode has been developed specifically for low cost, high volume designs in small signal applicatons, which is quite suitable to monitor the WiMAX signal [6].

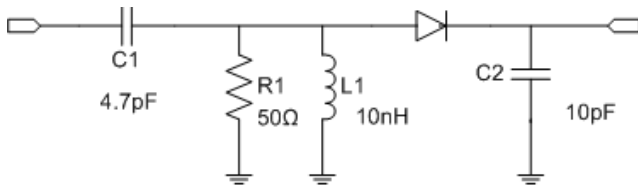

Figure 7. Schematic diagram of the zero-bias envelope detector circuit.

The RC constant is determined to monitor the WiMAX signal power at 2.3~2.4GHz with Eqn (3). The bandwidth is limited by the RC product of the circuit .

$$\frac{1}{RC} = 2\pi \times f \quad (3)$$

The input circuit is matched to the LNA for optimized sensitivity to mWiMAX signals at 2.3 ~ 2.4GHz[7]. This kind of Schottky diodes don't need DC bias circuit, because of its good voltage sensitivity[8].

4. Measurement and Estimation of power consumption in a circuit

The power consumption for the pre-scanning of the signal can be estimated from the DC power as,

$$P_{diss} = V_{ds} \times I_{ds} \quad (4)$$

Table 2. Power consumption in a circuit.

V_{gs}	V_{ds}	I_{ds}	P_{diss}
-0.6	3V	10mA	30mW
	3V	20mA	60mW

Therefore, this active detector is to spend 30mW, 60mW, respectively when $I_{ds} = 10mA$ and $20mA$. Also the power consumption can be minimized. because the envelope detector doesn't consume the DC power. With these bias, the device can detect the cw signal over -50dBm~-20dBm with output voltage over 4.23mV ~ 47mV. Fig.8 shows the detection results with CW signal at 2.35GHz. The detector is also measured with mWiMAX downlink signal of QPSK 3/4 . When the input power is -50dBm ~ -20dBm, the detector can monitor the output voltage 6.54 ~ 45.5mV. As a result, instead of using full demodulation, the detector is expected to recognize whether the WiMAX signal exists. The measured result is shown in Fig.8. As shown in Fig. 8

and Fig.9, the sensitivity is not quite different between two cases. The sensitivity is to be improved by careful tuning of the matching network between the detector and transistor output. In addition, almost constant gain(10~11dB) was achieved over the variation of the two bias conditions, which is useful and desirable for the detection of a high peak-to-average power ratio (PAPR) signals such as mWiMAX signals.

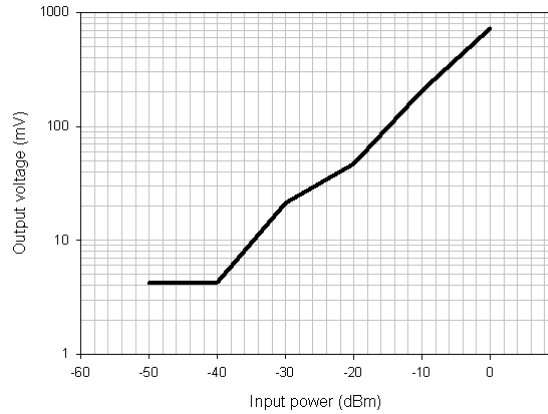

Figure 8. Detected voltage vs. input power for CW signal.

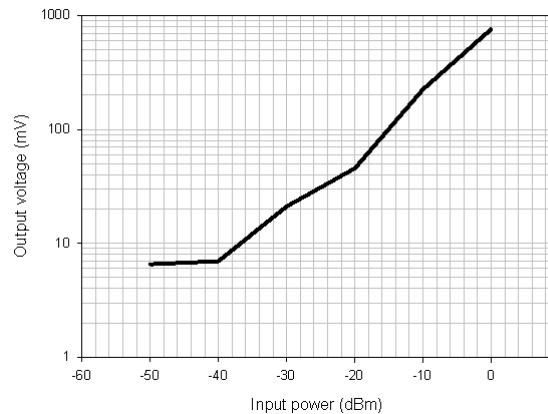

Figure 9. Detected voltage vs. input power for mWiMAX signal of QPSK 3/4.

Consequently, the power-consumption is reduced by more than 90% than the case of full demodulation of the mWiMAX signal, which consumes about 31mW with conventional design.

As a result, the power consumption to check the signal without the demodulation in the modem is calculated with $T_{DL} = 0ms$, $T_{ON} = 3 \tau ms$ and $T_{scan period} = 10sec$ in Eqn (1).

$$\begin{aligned}
P_{\text{avg}} &= P_{\text{modem,ON}} \times (T_{\text{DL}} + T_{\text{ON}}) / T_{\text{scanperiod}} \\
&= 30\text{mW} \times T_{\text{ON}} / T_{\text{scanperiod}} \\
&= 30\text{mW} \times (3 \times \tau) / T_{\text{scanperiod}} \quad (5) \\
&= 30\text{mW} \times (3 \times 50\text{ms}) / T_{\text{scanperiod}} \\
&= 1\text{mW}
\end{aligned}$$

Then, the average power consumption is calculated as below when the time constant τ is assumed about 50ms.

4. Conclusions

In DBDM handsets of mWiMAX and cellular functions, standby-mode power consumption is one of the major factor determining the battery life. Especially, when the terminal is out of the mWiMAX area, the mWiMAX modem has to perform full demodulation to check the existence of the mWiMAX signal, which generally takes hundreds of milliwatts for several hundred milliseconds. Therefore, in the effort of minimizing the power leakage when the terminal is out of the coverage, this paper suggests a wideband active detector to pre-scan the existence of the signal so that the terminal can save the time and power to demodulate the mWiMAX signal. As a result, the detector with 100KHz bandwidth and 11dB gain showed successful performance over -50dBm ~ 0dBm of input power. Consequently, the power consumption can be saved by more than 90% when the full demodulation is assumed to consume 600mW. For the following work, this device can be implemented in the baseband processor as a supplementary block to pre-scan the cell coverage.

References

- [1] *IEEE P802.16-REVd/D5-2004*, Three Park Avenue: IEEE, 2004.
- [2] Y. C. Park, "Minimization of Peak Current-Consumption in mobile-WiMAX and CDMA-cellular, Dual-mode Handsets" in *Proc. The 22nd International Technical Conference on Circuits/Systems, Computer and Communications*, Busan, Korea 2007.
- [3] *Low noise Pseudomorphic HEMT in a Surface Mount Plastic Package* Data Sheet : <http://www.avagotech.com>
- [4] Guillermo Gonzalez, *Microwave Transistor Amplifiers Analysis and Design*, Prentice Hall, 1997
- [5] *High Intercept Low Amplifier for the 1930-1990MHz PCS Band using the Avago ATF 34143 Low Noise PHEMT* Application Note 1191 : <http://www.avagotech.com>
- [6] *HSMS -285x Series Surface Mount Zero Bias Schottky Detector Diodes* Data Sheet : <http://www.avagotech.com>
- [7] *Impedance Matching Techniques for Mixers and Detectors* Application note 963 : <http://www.avagotech.com>
- [8] *All Schottky Diodes are Zero Bias detectors* Application Note 988 : <http://www.avagotech.com>