

Design of Waveguide Short-Slot 2-Plane Couplers

Dong-Hun Kim, Jiro Hirokawa and Makoto Ando

Dept. of Electrical and Electronic Engineering, Tokyo Institute of Technology
Tokyo, Japan

donghun.kim@antenna.ee.titech.ac.jp; jiro@antenna.ee.titech.ac.jp; mando@antenna.ee.titech.ac.jp

Abstract—A waveguide short-slot 2-plane coupler is proposed. It is designed to couple in the H- and E-planes, but should be considered propagation conditions of plural modes in the coupled region. Satisfying these conditions, the design of the coupled region and the ports is conducted. Its achieved bandwidth is approximately 2 % restricted by the frequency characteristic of the propagating modes in the coupled region.

Keywords—Antenna feed circuit, Beam forming, Butler matrix, Coupler, Waveguide passive device, Waveguide structure

I. INTRODUCTION

The waveguide short-slot coupler is one of components to divide and combine microwave power with a phase delay. It has small insertion loss and simple structure [1]. One of the authors proposes the waveguide short-slot 2-plane coupler as a component to realize two-dimensional beam-switching in Butler matrix by one body [2]. For acquiring the characteristic of hybrid or cross couplers, the structure of the coupler should be designed to satisfy four conditions on the propagating TE₁₀-like, TE₂₀-like, TE/TM₁₁-like and TM₂₁-like modes and the other evanescent modes.

In this paper, 2×2-way short-slot hybrid and cross 2-plane couplers are realized by consideration of given conditions.

II. SHORT-SLOT TWO-PLANE COUPLER

The short-slot hybrid and cross 2-plane couplers are designed. The operating frequency of these couplers is selected to 22 GHz. The design process consists of the cross-section of the coupled region, the ports, and the length of the coupled region. Then simulation results are presented.

For acquiring the characteristic of hybrid or cross couplers, the structure of the coupler should be designed to satisfy following 4 conditions.

Each of the conditions is explained in detail as follows.

1) Suppression of TE₃₀-like and TE₂₁-like modes

The broad-wall width a' of the coupled region is selected as shown in Fig. 1(b) to increase the cut-off frequency of the TE₃₀-like mode. The notches at the four corners of the cross section in the coupled region can suppress the TE₂₁-like mode so that they are placed along the electrical field of the TE₂₁-like mode in a PEC rectangular cross section.

2) Decoupling of TE₀₁-like mode

The TE₀₁-like mode in the coupled region should not have coupling with the input/output ports by adding the notches

from the broad-wall sides in the coupled region. In other words, if we would have notches from the narrow-wall sides, we could have coupling of the TE₀₁-like mode.

3) Balancing the coupling coefficients of the propagation modes

The dimensions and the positions of the ports are designed so that an incident mode in the port should have equal coupling with the four propagation modes in the coupled region. Instead of solving the problem on the coupling between the port and the whole coupled region, four problems on the coupling between the port and the quarter of the coupled region should be solved by assuming PEC and/or PMC walls at the two symmetrical planes of the coupled region properly for the symmetry of the corresponding four modes as shown in Fig. 3(b)-(e), respectively. We try to equalize the coupling among the four problems.

4) Relation among the propagation constants of the propagation modes

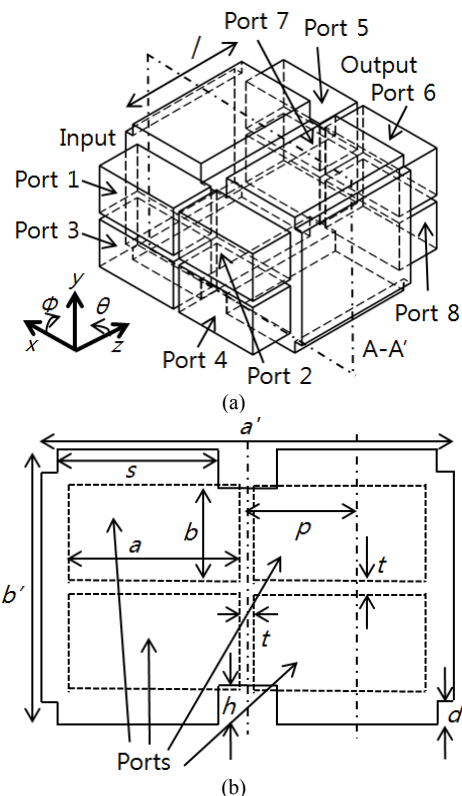

Fig. 1. 2×2-way short-slot 2-plane coupler. (a) Perspective view. (b) Cross-section of the coupled region (A-A', bold line).

This work is conducted in part by the Strategic Information and Communications R&D Promotion Programme, the Ministry of Internal Affairs and Communications.

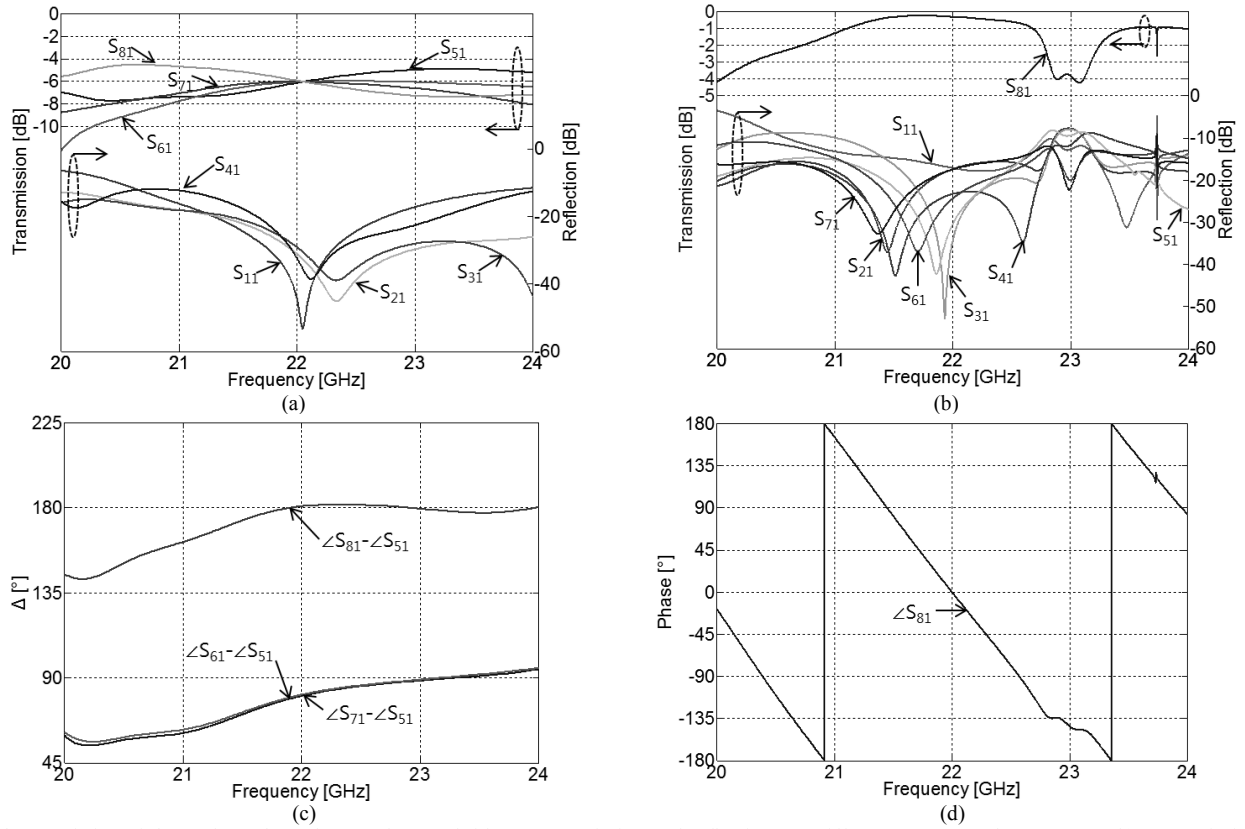

Fig. 2. Characteristics of the 2-plane short-slot couplers. Hybrid (a) Transmission and reflection (c) Differences among phases, Cross (b) Transmission and reflection (d) Phase.

When an input power from a port is assumed to transform to the TE₁₀-like, TE₂₀-like, TM/TE₁₁-like, and TM₂₁-like mode equally, the TE₂₀-like and TM/TE₁₁-like modes should have equal propagation constant.

$$\beta_{20} = \beta_{11} \quad (1)$$

The propagation constants of the TE₁₀-like, TE₂₀-like, and TM₂₁-like modes should satisfy the conditions to acquire the desired coupling coefficients of the output ports.

$$\text{Hybrid coupler} \begin{cases} \frac{l}{2}(\beta_{10} - \beta_{21}) = \frac{\pi}{2} \\ \frac{l}{2}(\beta_{10} - \beta_{20}) = \frac{\pi}{4} \end{cases} \quad (2)$$

$$\text{Cross coupler} \begin{cases} \frac{l}{2}(\beta_{10} - \beta_{21}) = \pi \\ \frac{l}{2}(\beta_{10} - \beta_{20}) = \frac{\pi}{2} \end{cases} \quad (3)$$

where β_{10} , β_{20} , β_{11} , β_{21} are the propagation constants of the TE₁₀-like, TE₂₀-like, TM/TE₁₁-like, and TM₂₁-like modes respectively, l is the length of the coupled region.

Briefly (2) and (3), a vital few relation among the propagation constants can be acquired by

$$\beta_{20} = \frac{\beta_{10} + \beta_{21}}{2} \quad (4)$$

The dimensions and the positions of the notches are selected to satisfy (4).

A. Cross-section of the coupled region

In a rectangular waveguide, the length of the broad and narrow walls can be determined by the cut-off frequency of propagating and evanescent modes. In the coupled region for the short-slot 2-plane coupler, six notches are inserted into the coupled region to disturb the flow of surface current of TE₂₁-like mode. It makes TE₂₁-like mode to evanescent mode. Maintaining TE₃₀-like mode to the evanescent mode in the operating frequency, we consider not only the length of the broad wall a' , but also the heights of the notches d and h in Fig. 1(b). The path length of surface current across the broad wall is dependent on these heights of the notches. If these heights are over the specified length, TE₃₀-like mode is changed to propagation mode. On the other hand, if these heights are below the specified length, TE₂₁-like mode is changed to propagation mode. Therefore the heights of notches should be chosen by considering these. The height and width of the center notches are key parameters for TE₂₁-like and TE₃₀-like modes to the evanescent modes. Finally, all the design parameters of the coupled region are selected to satisfy a relation among the propagation constants. The design parameters of the cross-section of the coupled region are listed in Table I for the center frequency of 22.0 GHz.

TABLE I
DESIGN PARAMETERS OF THE CROSS-SECTION OF THE COUPLED REGION [mm]

a'	b'	d	h	s	p	t
18.75	12.50	1.05	1.81	7.26	4.99	0.60

TABLE II
COUPLING AND PROPAGATION CONSTANTS OF THE PROPAGATING MODES AT 22 GHz

	TE ₁₀	TE ₀₁	TE ₁₁	TM ₁₁	TE ₂₀	TM ₂₁
β [rad/m]	435	379	358	306	301	177
C [dB]	-6.11	-28.80	-15.70	-6.51	-6.02	-6.22

B. Ports

The ports are arranged to two rows and two columns. The design parameters of the cross-section of the ports are selected to increase the coupling coefficients between the ports and the coupled region.

Due to the reason of fabrication, the distances between the ports are limited 0.6 mm. The broad and the narrow wall lengths of the ports are selected to $a = 7.85$ mm and $b = 4.35$ mm, respectively. The 2-plane short-slot hybrid coupler is followed these design parameters. On the other hand, the design of the 2-plane short-slot cross coupler is considered the discontinuity of waveguides in the 2-D beam-switching Butler matrix, the broad and the narrow wall lengths of the ports are same to the hybrid coupler's and the distances between the ports are 3.05 mm (H-plane) and 3.8 mm (E-plane).

The coupling coefficients and the propagation constants of the propagating modes are listed in Table II. TE₀₁-like and TE₁₁-like modes have lower coupling coefficient than other propagation modes. These modes can be ignored to contribute the generation of electric field in the coupled region. Considering the propagation constants listed in Table II, the lengths of the coupled region in the short-slot 2-plane hybrid and cross couplers are selected to 11.57 mm and 21.72 mm, respectively.

C. Simulation results

The bandwidth of the short-slot 2-plane couplers are 2.3 % from 21.8 GHz to 22.3 GHz where the transmission at the output ports are within -6.1 ± 0.5 dB, the phase differences

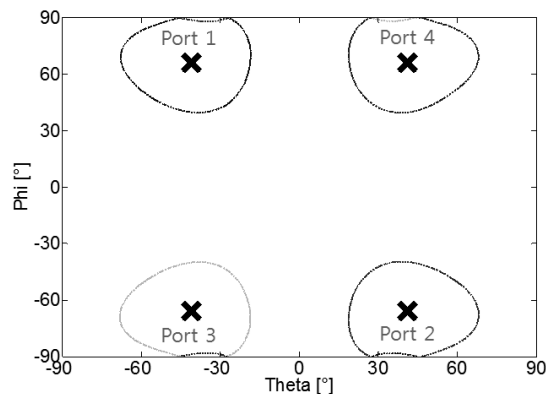

Fig. 3. 3 dB gain patterns of short-slot 2-plane hybrid coupler at 22 GHz

among the output ports are within $81 \pm 3.7^\circ$ and $180.3 \pm 1.5^\circ$, and the reflection at the input ports are under -18.5 dB as shown in Fig. 2(a) and (c). The short-slot cross 2-plane coupler has the transmission (> -0.7 dB), the reflections and the isolations (< -12.8 dB) at the output port as shown in Fig. 2(b) and (d). A short-slot 2-plane hybrid coupler substitutes a 2×2 -way 2-D beam-switching Butler matrix. It generates four 2-dimensional radiation patterns corresponded to four inputs as shown as Fig. 3.

III. CONCLUSION

The 2×2 -way short-slot 2-plane couplers are discussed. The cross-section of the coupled region is designed by considering the electric field distribution and the cut-off frequency of plural modes. The lengths of the coupled region are selected to correspond to the hybrid and the cross couplers. The size of the ports of the short-slot 2-plane couplers is focused on the hybrid coupler for manufacturing and connecting of waveguides. The short-slot 2-plane hybrid coupler works as a 2×2 -way 2-D beam-switching Butler matrix. Because there are four modes which have different propagation constants, the operating frequency band is restricted.

REFERENCES

- [1] H. J. Riblet, "The short-slot hybrid junction," *Proc. IRE*, vol. 40, pp.180-184, Feb. 1952.
- [2] J. Hirokawa, "Configuration of a Two-dimensional Beam-switching Butler Matrix and Feasibility of a Two-plane-dividing Short Slot Coupler," *Proc. IEICE General Conf.*, B-1-48, Mar. 2015.