

A Grid Array Antenna with Parasitic Monopoles

Toru Kawano*

Department of Communications Engineering
National Defense Academy
Yokosuka, Kanagawa, Japan 239-8686
tkawano@nda.ac.jp

Hisamatsu Nakano

Department of Electrical and Electronic Engineering
College of Science and Engineering, Hosei University
Koganei, Tokyo, Japan 184-8584
nakano@hosei.ac.jp

Abstract— A system composed of a grid array antenna (GAA) and parasitic monopoles is analyzed. The analysis is performed using an integral equation with the method of moments to reveal the radiation pattern, axial ratio, half-power beam-width and gain. It is found that the parasitic monopoles contribute to transforming a linearly polarized beam from the GAA into a circularly polarized beam. It is also noted that this circularly polarized beam is almost symmetric with respect to the antenna axis normal to the GAA.

Keywords—grid array antenna; parasitic monopole; broadside beam; circularly polarized beam

I. INTRODUCTION

A grid array antenna (GAA) composed of numerous grid cells has been invented by Kraus [1]. It is explained qualitatively that the short and long sides of the unit cell act as a radiation element and a feed network element, respectively [1]. It follows that the radiation field is linearly polarized (LP) parallel to the short side of the grid cell.

When the GAA is fed from the antenna edge, the LP radiation is tilted. On the other hand, the GAA is fed from its center region, the LP radiation is in the broadside direction [2]. These facts have been quantitatively revealed using an integral equation [3] with the method of moments (MoM) [4].

Recently, circularly polarized (CP) GAAs have also been investigated [5]-[7]. In [5], parasitic c-shaped elements are placed above the GAA. In [6], four GAAs are excited by a 90° progressive/regressive phase relationship. In [7], loops are used for radiation elements.

This paper is a sequel to the CP grid in [5], where the c-shaped elements are modified to monopoles (mp). This antenna is designated as the mp-GAA. The radiation characteristics of the mp-GAA are analyzed using the integral equation [3] with the MoM [4], as in [2]. It is shown that the mp-GAA radiates a CP beam in the broadside direction.

II. CONFIGURATION

Figure 1 shows antenna system where parasitic wire monopoles are placed above a grid array (mp-GAA). The

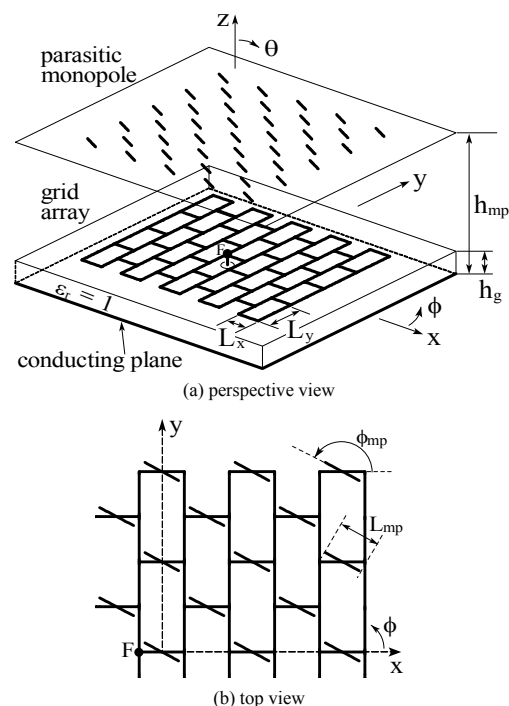

Fig. 1. Configuration and coordinate system of mp-GAA

conducting plane for the GAA is assumed to be of infinite extent. The heights from the conducting plane to the grid cell and the monopoles are h_g and h_{mp} , respectively. The short- and long-side lengths of the grid cell are L_x and L_y , respectively. The length and rotation angle of the monopole are L_{mp} and ϕ_{mp} , respectively. The wire diameter is $2a$. The mp-GAA is fed by a coaxial line from point F, which is located near the central region of the GAA.

III. DISCUSSION

The radiation characteristics of the mp-GAA are analyzed using an integral equation [3], derived for an arbitrary shaped antenna, with the MoM [4]. To obtain the current distribution along the mp-GAA, a piecewise sinusoidal function is used for basis and weighting functions in the MoM. The radiation characteristics are calculated using the obtained MoM current

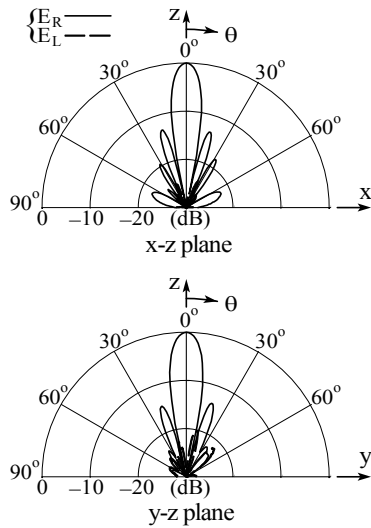

Fig. 2. CP radiation from the mp-GAA

distribution.

Fig. 2 shows radiation from the mp-GAA, which is decomposed into two components: a right-handed CP component E_R and a left-handed CP component E_L , where the following configuration parameters are used: $h_g = 0.1\lambda_{12}$, $h_{mp} = 0.23\lambda_{12}$, $L_x = 0.53\lambda_{12}$, $L_y = 2L_x = 1.06\lambda_{12}$, $L_{mp} = 0.45\lambda_{12}$, $\phi_{mp} = 151^\circ$, and $2a = 0.012\lambda_{12}$, where λ_{12} denotes the free space wavelength at a test frequency 12 GHz.

It is found that the half-power beam width (HPBW) is 11° in the x-z plane and 12° in the y-z plane. The gain is approximately 22 dBi for a right-handed CP wave. The cross-polarization component (E_L) is small (less than -20 dB). For

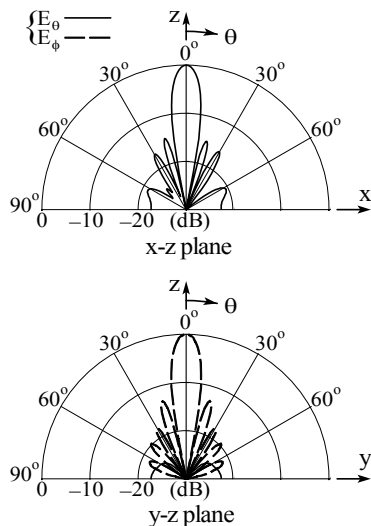

Fig. 3. LP radiation from a GAA without parasitic monopoles

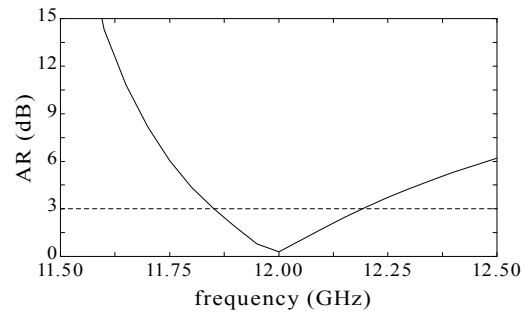

Fig. 4. Axial ratio as a function of frequency

comparison, the radiation pattern when the parasitic monopoles are removed is illustrated in Fig. 3. This GAA radiates an x-directed linearly polarized (LP) beam, where the HPBWs in the x-z plane and y-z plane are almost the same and 10° . These HPBWs are very close to those for the mp-GAA. It can be said that the parasitic monopoles act as a polarization transformer that does not affect the radiation pattern.

Figure 4 shows the axial ratio for the mp-GAA as a function of frequency. The axial ratio at 12 GHz is calculated to be 0.3 dB. The frequency bandwidth for a 3 dB axial ratio criterion is approximately 3% (from 11.85 GHz to 12.2 GHz).

IV. CONCLUSIONS

The radiation characteristics of a grid array antenna with parasitic monopoles (mp-GAA) have been analyzed using an integral equation with the method of moments. It is found that the parasitic monopoles act as a polarization transformer not affecting the radiation pattern. The radiation from the mp-GAA is circularly polarized in the broadside direction with good axial ratio.

REFERENCES

- [1] J. D. Kraus, "A backward angle-fire array antenna," *IEEE Trans. Antennas Propag.*, vol. AP-12, no. 1, pp. 48–50, Jan. 1964.
- [2] H. Nakano, I. Oshima, H. Mimaki, J. Yamauchi, and K. Hirose, "Center-fed grid array antennas," *IEEE AP-S Int. Symp.*, pp. 2010–2013, June 1995.
- [3] H. Nakano, *Analysis Methods for Electro-magnetic Wave Problems*, E. Yamashita Ed., Norwood, MA: Artech House, vol. 2, chap. 3, 1996.
- [4] R. F. Harrington, *Field Computation by Moment Methods*, Macmillan Company, New York, 1968.
- [5] T. Kawano and H. Nakano, "A grid array antenna with c-figured elements," *Electronics and Communications in Japan*, part 1, vol. 85, no. 1, pp. 58–68, Jan. 2002.
- [6] T. Kawano and H. Nakano, "A bowtie-shaped grid array antenna radiating linearly and circularly polarized beams," *IEEE AP-S Int. Symp.*, July 2015 (to be published).
- [7] H. Nakano, Y. Iitsuka, and J. Yamauchi, "Loop-based circularly polarized grid array antenna with edge excitation," *IEEE Trans. Antennas Propag.*, vol. AP-61, no. 8, pp. 4045–4053, August 2013.