

Analysis on the effect of heating coil in micro-speakers for smart car

Hyun-Kab Kim¹ and Hie-Sik Kim², Dalwon Jang³, Jongseol Lee⁴, Sei-Jin Jang⁵

^{1,2} Department of Electrical Engineering, University of Seoul

The Univ. of Seoul, Jeonong 2-dong, Dongdaemun-gu, Seoul, Korea

^{3,4,5} KETI(Korea Electronics Technology Institute)

KETI, 195, Baengma-ro, Ilsandong-gu, Goyang-si, Gyeonggi-do, Korea

E-mail: ¹hyunkab@keti.re.kr, ²drhskim@uos.ac.kr, ³dalwon@keti.re.kr, ⁴leejs@keti.re.kr, ⁵sjjang@keti.re.kr

Abstract: Loud speakers, which are representative transducers, have non-linearity, thus that requires for speaker researchers to measure loud speakers precisely. In particular, micro-speakers, which are used in potable devices as smartphones, have bad situation for generating sound compared to other sound emitting objects. Thus, more careful measurement is necessary. In this paper, the effect of heating coil through the pre-driver in the micro-speakers with a voice coil is presented. The experimental results related to coil heating is shown, and from the result, this paper can know coil heating is necessary for precise measurement of micro-speakers.

Keywords-- Voice coil, transducer, thermal, measurement, micro-speakers

1. Introduction

Loudspeaker is a typical device having a non-linearity. Unlike the electric conversion device for changing the electrical signal in the same domain, the speaker is affected by various environmental factors. Particularly in the case of using a moving coil speaker, conversion efficiency, mechanical variables, and thermal properties are largely influenced. Therefore, a precise measurement is required in the course of product development.

This paper deals with measurement of micro-speakers which are main components of smart phones, and media sound of the Smart car(Including the IoT network). Demand of micro-speakers is rapidly increasing. Many micro-speaker diaphragms having a diameter of less than 20mm and a thickness of 10 μm use the film material [1]. Because of the small size and the limited displacement of speakers, they have a harsh environment as a sound emitting object. For this reason, when they are excited in large displacement, the degree of heating of the moving coil is expected to affect the measurement results.

In this paper, the main focus is not the on conversion relationship due to heating of voice coil. The relationships between the pre-conditions of measurement and test result will be described

2. Heating coils measurement

Experiments to find out the effect of the heating coil micro-speaker is shown in Figure 1.

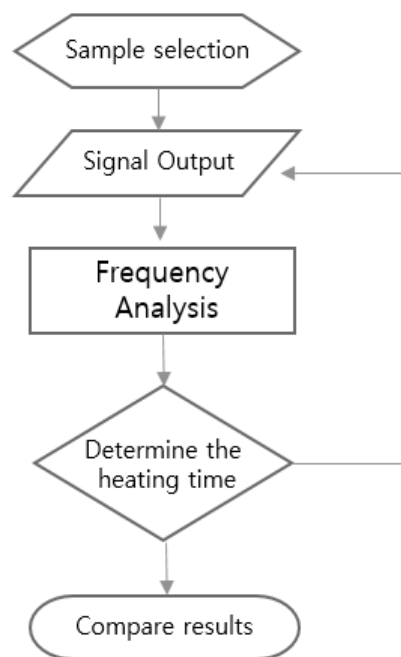

Figure 1. The process for experiments of heating coil microspeaker

2. 1 Sample for measurement

Micro speaker using the voice coil structure of the divided by driving force type, geometric structure, and permanent magnet position. The electrodynamic (Dynamic) and electrostatic (Electrostatic) can be classified by driving method. The cone (Cone type), Honhyon (Horn type), and plate type (Plate type), etc. can be sorted by geometric structure. The core magnet(P-type), ring magnet(F-type) can be divided by permanent magnet position[2].

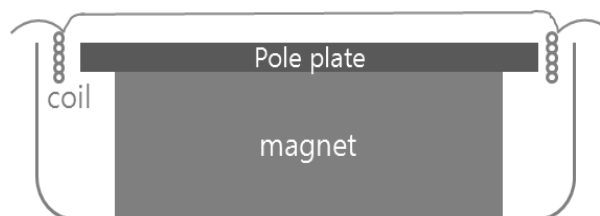

Figure 2. Magnet core type Flatbed micro speakers Construction

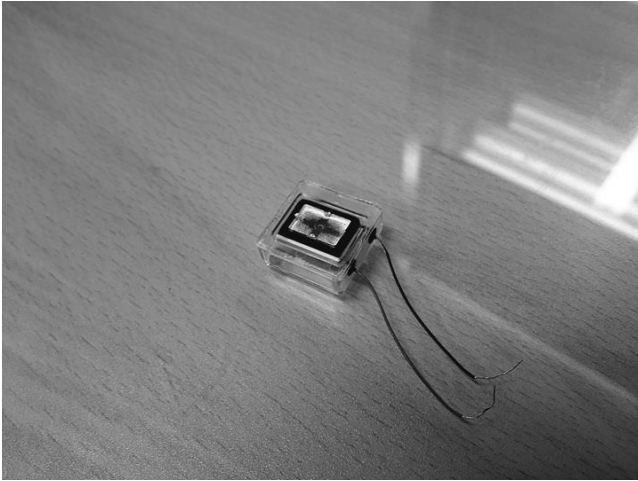

Figure 3. Test sample

In this paper, we use plate-type and core magnet speakers which is commonly used in micro speakers. Further, a sample of closed box-type which rear air volume is enveloped was used to simulate the actual thermal load environment. Simple structure view of the product is the same as Figure. 2, the sample image can be seen in Figure 3. Closed box type speaker are mainly used in smartphones which allow only narrow and thin space, and often used in acoustic component of a motor vehicle that is buried in cluster with complex equipment.

2. 2 Speaker measurement process

This experiment is to determine the effect of voice coil heating caused by pre-load. Here we will focus on changes in the frequency response characteristic and the impedance characteristic graph. Frequency response characteristic and the impedance characteristic is one of the typical parameters of the speaker. Frequency response is a basic item in acoustic measurement of the speaker, the impedance characteristic is an electrical parameters showing typical characteristics of the composite LRC speakers have. LRC generally mean inductance (L), resistance(R), Capacitance(C) respectively.

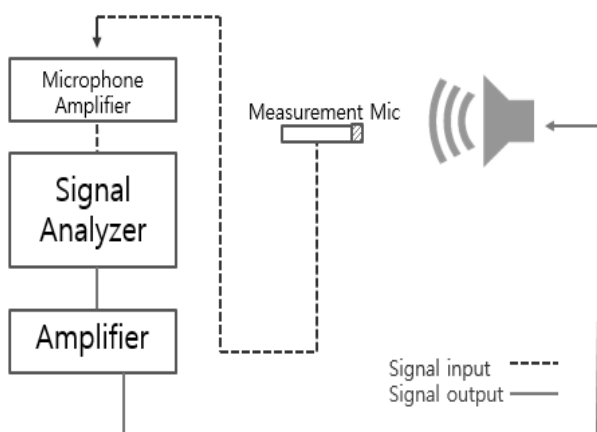

Figure 4. The experimental structure of speaker measure

System used for the measurement, comprehensive analysis APx585 impedance boxes IMP1 the Audio Precision, and B & K Power Amplifiers 2716C and conditioning amplifier 2690, measurement microphone 4191-L-001, is composed of a calibrator 4231.

This test was performed under the IEC speaker measurement standards[3]. But, since the test is for relative comparison, the test was done in a typical room environment, 10 cm away from DUT, rather than free-field conditions. To remove the reflected sound, windowing was applied in the time domain. Flatness of the frequency response of micro speaker and near field effect are not considered in this experiment.

Samples used have 8 ohm nominal impedance, supplied with 2.828 Vrms corresponding to 1W characteristic voltage. This voltage cannot be regarded as a large signal in most case. But in case of the micro-speakers, it is not corresponding to the small signal level. Since for large signal input, the part of many characteristic parameters entering the nonlinear level, in this experiment, we construct a basic pre-drive environment according to 1 W.

2. 3 Measurement results

The measurement results are displayed on the two entries of frequency response characteristic and the impedance graph. The difference in the frequency response characteristic of the Normal graph (dotted line) which are not pre-driven and five graphs which are pre-driven for 1 to 5 minutes can be identified in Figure 5. As a result, after 3 minutes, the difference in the outcome seems to be reduced. Likewise, for the graph of impedance, Figure 6 shows the results of none-pre-driving and 1 to 5 minute pre-driving and changes in the resonant frequency.

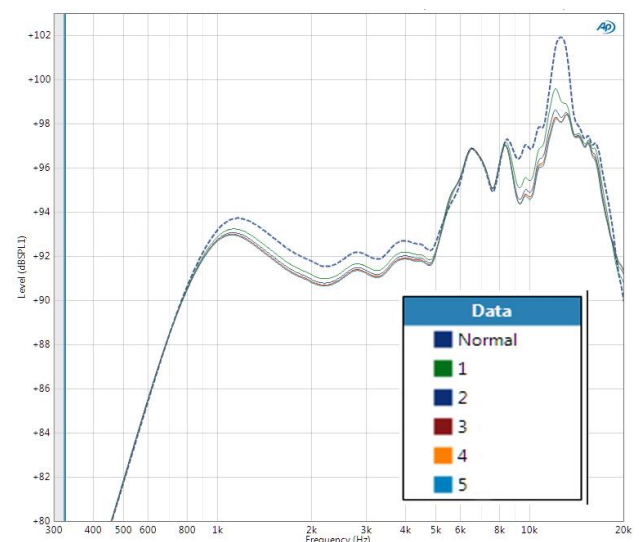

Figure 5. Differences in the frequency response

Frequency response characteristics in Figure 5. shows a fairly large enough change to be easily distinguish Normal (not pre-driven) graph and pre-driven ones for 1 to 5 minutes. One can know that the shape of curve of frequency

response are changing by pre-driving, not simply the decay in sound pressure level.

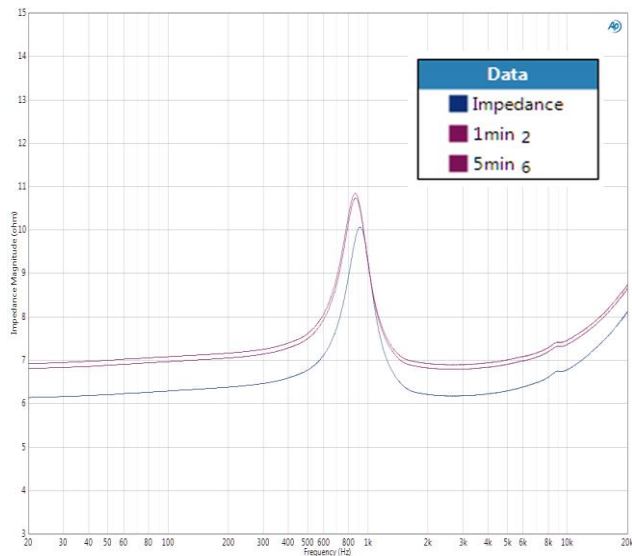

Figure 6. Differences between the impedance graph

Not like the changes in frequency responses, the impedance in Figure 6. converges without big changes after 1 minute of pre-driving . The relation between increase of resistance and temperature can be observed as shown in general analog elements. However, as a result of combined effect, it is possible to identify the change in the maximum resonance frequency also, not just shift of the curve. Since this change in the maximum resonance frequency is the important reference point in the speaker design, the direction of movement is very important.

3. Conclusion

In general, characteristics of the micro-speaker can be determined by some parameters such as the resonance frequency, the output (Sound Pressure Level) and Total Harmonic Distortion (THD) [4]. However, this property cannot be viewed as a fixed value. In real usage situations, speakers are excited for long-term period over a certain volume level. In the experiments of this paper, a pre-driving condition which reflects the situation is suggested and confirms the change in the impedance and the frequency response due to coil heating.

Therefore, the degree of change by the coil heating should be measured in advance and be measured in a stable driving environment for meaningful measurement results for accurate analysis of a micro speaker. Speaker driven in the real environment is not for a single reproduction of the short measurement signal. One must always take into account the fact that the voice coil of speakers are being heated sufficiently in the process of continuous reproduction situation.

This paper, we examined the results of the changes in the properties of a specific micro-speaker unit by the coil heating. By that, we found that the coil heating affects the

characteristic change of the speaker and the period of pre-driving which is degree of thermal load changes the tendency.

However, in the present study, the experimental sample was limited, less parameter values were considered as variables. Therefore, the type-specific modeling of coil heating was not derived.

Therefore, for the future works, the micro-speaker of various forms will be classified according to structure and more subject parameters be prepared to quantify the component and establish modeling of heat-load. Finally, we will try to seek for guidelines for the optimal design to be applied to the composite media devices such as a smart car.

4. Acknowledgement

This work was supported by Institute for Information & communications Technology Promotion (IITP) grant funded by the Korea government (MSIP) (No. B0101-15-0426, Development of the Smart convergence SW platform based on open software for new convergence services in mobile seconds branch)

References

- [1] Jung, Kyung-II, Yi, Han-Ryang, Oh, Sei-Jin, Yoon, Suk-Wang, "Behaviour of Micro-loudspeaker Diaphragms", Proceedings of the Acoustical Society of Korea Conference, vol 23, no 2(s), pp.499-502, 2004
- [2] Kyeong Min Kim, Seong Keol Kim, and Keun Park, "Investigation on Vibration Characteristics of Micro Speaker Diaphragms for Various Shape Designs", Journal of the Korean Society of Precision Engineering / v.30 no.8, pp.790-796, 2013
- [3] Korean Agency for Technology and Standards, "Sound system equipment – Part 5 : Loudspeakers", KS C IEC 60268-5, 2010
- [4] Sei-Jin Oh, Hae-Young Kim, "Correlation Between Tensile Strength of Diaphragm and Resonance Frequency for Micro-Speaker", The journal of the acoustical society of Korea, v.28 no.4, pp.299-307, 2009