

Limited Area Communication Using Sum & Differential Patterns

Mitoshi Fujimoto, Kenji Takemoto, Toshikazu Hori
Graduate School of Engineering
University of Fukui
3-9-1, Bunkyo, Fukui, Japan

Abstract— In this paper, a novel communication system for limited area communication is proposed. In the proposed system, sum pattern and differential pattern is used. A main beam of the sum pattern is directed to the direction of the desired user and signal for communication is transmitted using the main beam. On the other hand, a null of the differential pattern is also directed to the desired user and a jamming signal is transmitted using the differential pattern. Numerical results show that the communication area is limited by interference due to the jamming signal while the communication distance is not affected.

Keywords—limitation; sum pattern; differential pattern;

I. INTRODUCTION

In recent years, wireless communication systems are widely spread and lots of users communicate via wireless communication links [1]. To cover the many users as possible, long communication distance is preferable. On the other hand, on the view point of security, communication area should be limited in the specific direction where the desired terminal is present.

Array antenna is one of the promised techniques to form the arbitrary radiation pattern [2]. In generally, many antenna elements are required to form narrow beam pattern and it make high cost. The gain of array pattern is decreased as the beam width is decreased. Then, the distance of communication is also decreased [3].

In this paper, a novel communication technique for limited area communication is proposed. In the proposed system, desired signal is transmitted using sum pattern of the array antenna while jamming signal is transmitted using differential pattern.

A concept and configuration of the proposed system is provided in Sec.2 and validity is indicated via numerical simulation in Sec.3. The paper is summarized in Sec. 4.

II. PROPOSED AREA LIMITEATION COMMUNICATIN SYTEM

A. Concept of Poposed System

Fig.1 shows the concept of the proposed system. In the proposed system, two kinds of array pattern are used. One is sum pattern which is used for communication. It is usual array pattern as same as a phased array and the main beam of the sum pattern is directed to the desired direction. The other is

differential pattern which is utilized for limiting the receivable area. A null of the differential pattern is directed to the direction of the main beam of the sum pattern and a jamming signal is transmitted using the differential pattern. Since the jamming signal is not radiated to the null direction, the communication quality in the desired direction is not affected by the jamming signal. On the other hand, correct reception is jammed by the jamming signal except for the null direction. Since the width of the null is very narrow, the direction where the reception area becomes narrow compared to the case of the usual phased array.

B. Configuration of proposed system

Fig.2 shows an example of the configuration of the proposed system. It is supposed in this example that 8-elements are used for sum pattern. And only 2-elements are used for the differential pattern because 2-elements differential pattern has only one null. Since the only one null is directed to the direction of the main beam of the sum pattern, all of the other directions are jammed by using the 2-elements differential pattern. A part of the elements of the sum array is co-used to the differential array as shown in Fig.2.

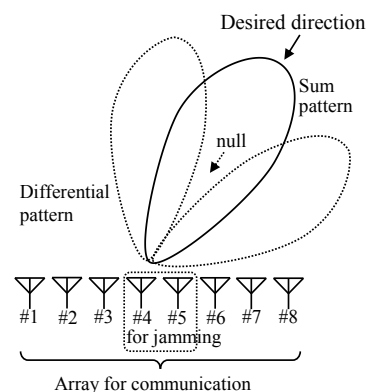

Fig.1 Concept of proposed system

III. COMMUNICATION AREA OF PROPOSED SYSTEM

Fig.3 shows the numerical results of the proposed system. Fig.3 (a) (Left side of Fig.3) is the case that the main beam and null is directed to broad side direction. The top figure of the Fig.3 (a) is the sum pattern and differential pattern. The middle figure shows the communication area by the proposed system.

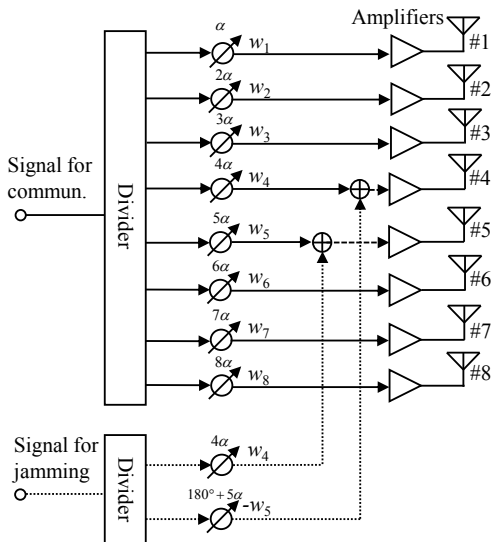

Fig.2 Configuration of proposed system

The brightness indicates the bit error rate. The bottom figure of the Fig.3 (a) shows the bit error rate in case of conventional phased array for a reference. As we can see, the communication area of proposed system is narrower compared to the case of conventional one. And also we can find that the communication distance of the proposed system is almost the same with conventional one even if the area becomes narrow.

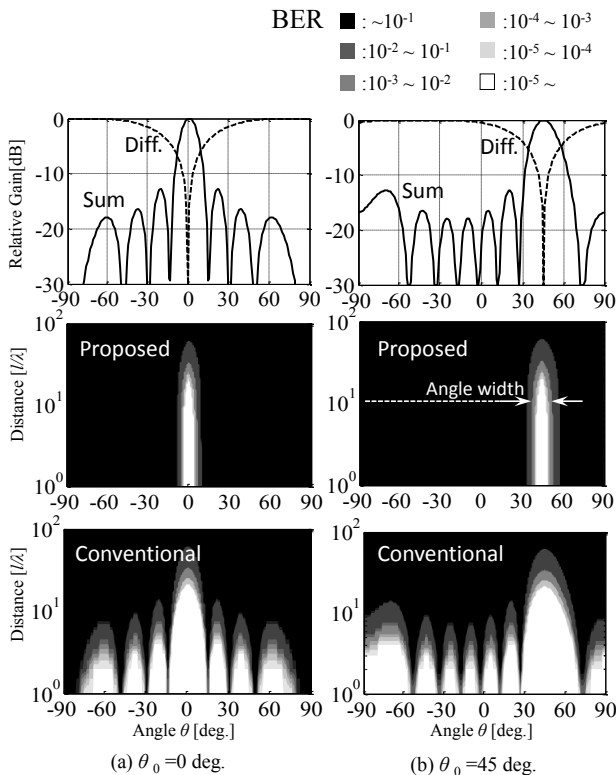

Fig.3 Limitation effect of proposed system

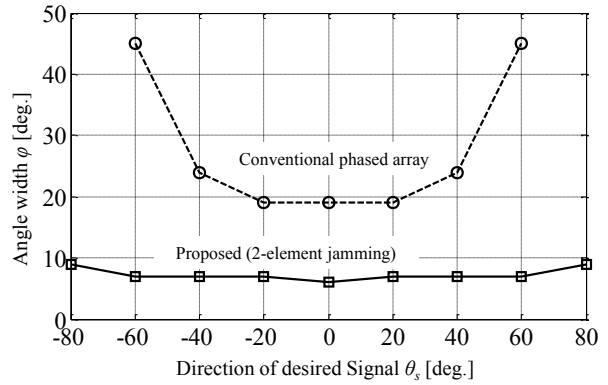

Fig.4 Effect of desired direction

Fig.3 (b) shows the result in case that the direction of the main beam and null is shifted 45 deg. from the broadside direction. As the same with the Fig.3 (a), the top figure, the middle figure and the bottom figure is the directional pattern, the communication area by the proposed system and that of the conventional phased array, respectively. We can find from figure that the communication area of the proposed system is still narrow while the area of the conventional system becomes wide.

IV. EFFECT OF DIRECTION ON COMMUNICATION AREA

We evaluate the area limitation effect by using “Angle width” of the communication area in this paper. The “Angle width” is defined as the angle width that the communication distance is longer than 10 wavelengths as shown in Fig.3. Fig.4 shows the variation of “Angle width” when the direction of desired signal is changed. The solid line and dashed line shows the results of the proposed configuration and the conventional phased array, respectively. In the case of the conventional configuration, the “Angle width” is considerably affected by the desired direction. Especially, the “Angle width” becomes large as the direction closes to the end-fire direction. On the other hand, the “Angle width” of the proposed method does not depend on the direction and it is almost a constant.

V. CONCLUSION

A novel communication system for area limitation was proposed. In the system, the sum pattern was utilized for communication while the differential pattern was utilized for area limitation. It was shown that the communication area was limited by the proposed configuration. It was also shown that the communication distance was not affected even if the angle was limited.

REFERENCES

- [1] J. G. Proakis, Digital Communications (McGraw-Hill Inc.,1995. 3rd edn.)
- [2] W.L. Stutzman and G.A. Thiele: “Antenna theory and design,” John. Wiley and Sons, 2nd Edition, 1998.
- [3] M. P. Daly, IEEE Trans. Antennas Propagat., vol.57, pp.2633-2640, 2009.