

Development of Nearby Cluttered Tags Detection Unit with UHF-RFID Technology

Kyosuke Mayama, Yoshinobu Okano

TOKYO CITY UNIVERSITY

1-28-1, Tamadutsumi, Setagaya-Ku, Tokyo, Japan 158-8557

g1581524@tcu.ac.jp, y-okano@tcu.ac.jp

Abstract — Recently, the system for closely-spaced tag management (at 13.56 MHz) and the system for the long distance identification (at 920 MHz) have been carried out to practical use. For continuous logistics, it is desired that those are integrated seamlessly. However, integration into the system, which uses the frequency band of 13.56 MHz, is disadvantageous to keep the feature of the long distance identification. In this paper, the system which identifies nearby cluttered tags by the frequency band for the long distance identification is described.

Keywords — RFID, UHF band, RF-Tag, detector, the leaky coaxial cable

I. INTRODUCTION

Recently, radio frequency identification (RF-ID) system is noticed as a distribution management system that replaces the bar code. There are two types of present RFID systems (the electromagnetic coupling use type and the microwave-use type).

The electromagnetic coupling use type system (HF-RFID) has the property to which the identification precision is steady for environmental changes. Therefore, this system is suitable for the detection of closely-spaced RF-tags. However, it is unsuitable for few meters distance or movement RF-Tag detection.

In contrast, the microwave-use type system (UHF-RFID) is suitable for few meters distant or traveling RF-tags detection, because the detection signal transmission efficiency is high [1]. Though, the suppression technology of electromagnetic interference is necessary for the detection of closely-spaced RF-tags.

In detailed management of a physical distribution, if closely-spaced tags detection and distant tags detection system are unified, that is so useful. Although, the integration of those systems are not easy. The reason is that the equipment cannot be shared because the frequency band is substantially different.

Improving the detection distance of the HF-RFID system is attended with a lot of technical difficulties. On the one hand, the electromagnetic interference suppression method for the UHF-RFID system exists variously. In this paper, these two systems are integrated by UHF-RFID. The proposed unit searches tags that are cluttered in two dimensions. As for the

apparel industry segments, because neither metallic objects nor moisture exist near RF-tags, those identifications with UHF-RFID system are easy, though RF-tags have been closely-spaced. In such industry segments, the distant or traveling RF-tags detection is required in the delivery confirmation, the detection of closely-spaced RF-tags are also required in the sales confirmation (refer to Figure 1). Accordingly, closely-spaced RF-tag detector unit that uses the UHF-RFID system will be demanded.

The following chapters report on the electromagnetic interference suppression technique for closely-spaced RF-tags with UHF-RFID system.

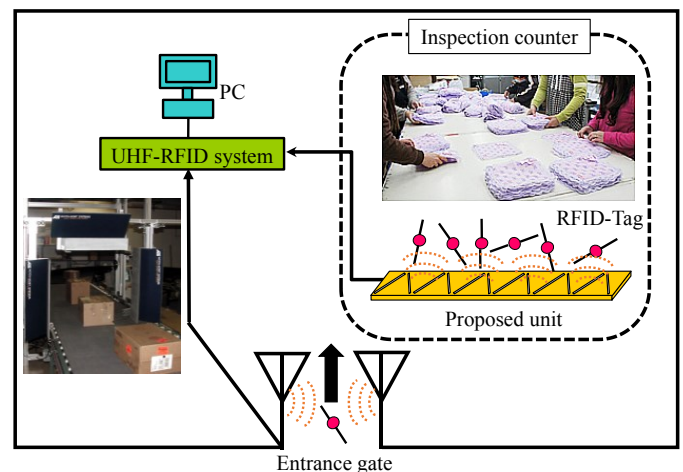

Fig. 1 Integration of a UHF band RFID system

II. CONFIGURATION OF THE PROPOSED UNIT

The proposed unit is required to search cluttered tags without electromagnetic interference. If this proposal is realized, seamless management will become possible. The cluttered tags detector proposed in this paper referred to the leaky coaxial cable [2]. The proposal tag detector has flat shape that fitting to the commodity identification work desk is considered though general leaky coaxial cable's form is a cylindrical shape. The structure of the proposed unit is shown in Figure 2 in detail. A flat shape cable is called shielded type microstrip-line. The proposed unit is composed with putting

slot apertures on the outside metal layer of shielded type microstrip-line.

In design or performance evaluation of the proposal cluttered tags detector, finite-difference time-domain (FDTD) method is used as numerical analysis [3]. The relative permittivity and the conductivity of the dielectric substrate in shielded microstrip-line is set to $\epsilon_r = 3$, $\sigma = 0.0005$ [S/m].

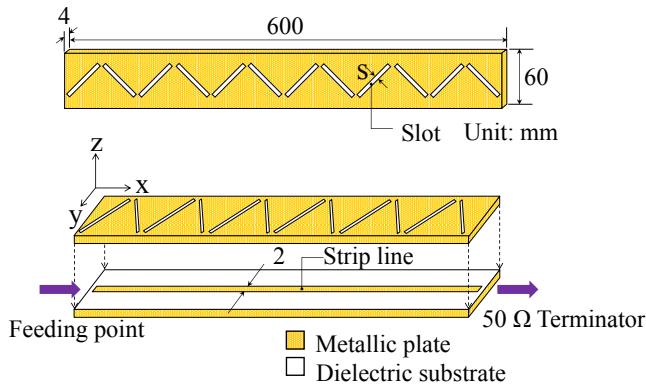

Fig. 2 Configuration of the cluttered tag detector unit.

III. ANALYSIS RESULTS

A. Study on the slot width

The composite electric field which synthesized X-component and Y-component of electric field is used as the performance evaluation index because the proposed unit search scattered tags on X-Y plane in Figure 2. It is assumed to inquire into tags attached in the commodity on the inspection counter with the proposal unit. Hence, electric field distribution on the reference plane 50mm (assumed thickness of folded clothes) away from the detector unit is evaluated. The electromagnetic radiation from the antenna for long-range detector is used for the performance evaluation index of the proposed tag detection unit. Many of antennas for long-range Reader/Writer are enabled for tag to be detected by 90 % or more if the distance between it and a target tag is within 2 m. Consequently, the electric field for the performance evaluation index is normalized with the electric field of the high-gain patch antenna (around 8 dBi) above 2 m. Specifically, when normalized electric field is 0 dB, actual electric field shows 0.27[V/m]. When the normalized the electric field level is 0 or more, tag will be certainly found with proposal unit.

Figure 3 shows the slot width 's' dependency of the electric field distribution along the tag detection unit. From those results, it can be seen that the electromagnetic radiation is increased by enlarging the slot width. Although, it is not desired that the radiation from one unit be excessive because the proposal unit should be made a series array to inquire into

two-dimensional cluttered tags. It is not appropriate to expand 's' to 9 mm or more.

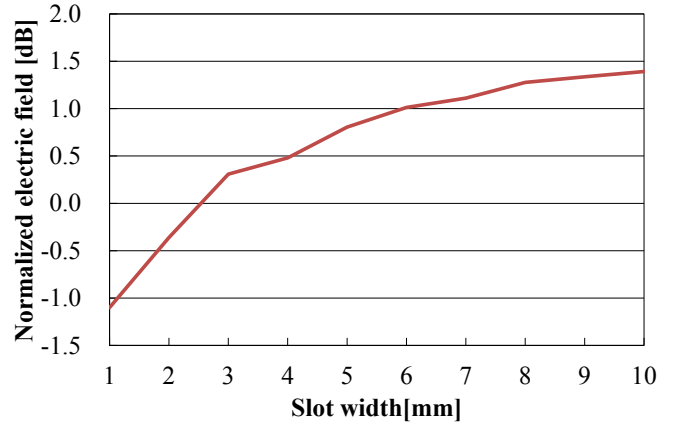

Fig. 3 Normalized electric field of changing the slot width

B. Study on the number of slots

The radiation field from the cluttered tags detector greatly depends on the slot length and number of slots. In this section, the radiation field from tags detector when the slot length and number of slot are sequentially changed is evaluated.

Figure 4 shows normalized electric field distribution away 50 mm from the unit. It can be seen that the normalized electric field above the unit is a positive value.

Figure 5 shows the analysis results of changing the slot length and number of slots. The all slot width is set to 9 mm. Figure 5(a) is 6 slots type, (b) is 9 slots type, (c) is 12, (d) is 15. All these electric field strength is normalized with electric field strength of the high-gain patch antenna in 2 m distance. As for 6-slot and 9-slot unit, the X-component electric field shows the tendency to decline in the gap between slot apertures. In the radiation field from the 12 slots type unit, the field distribution is smooth, and the difference between the X and Y components is not so large. On the other hand, the radiation field from the 15 slots type unit is worse than with the 12 slots type unit. Those results suggest that the radiation level from the tags detector be deteriorated, if the slot length shorten even if the number of slots increases.

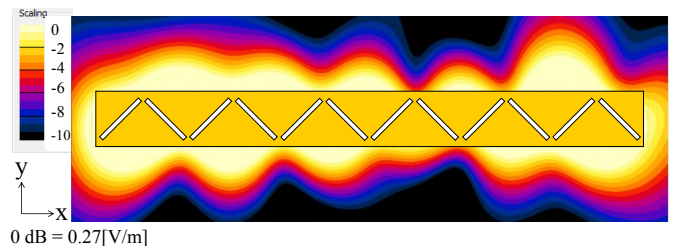

Fig. 4 Normalized electric field distribution

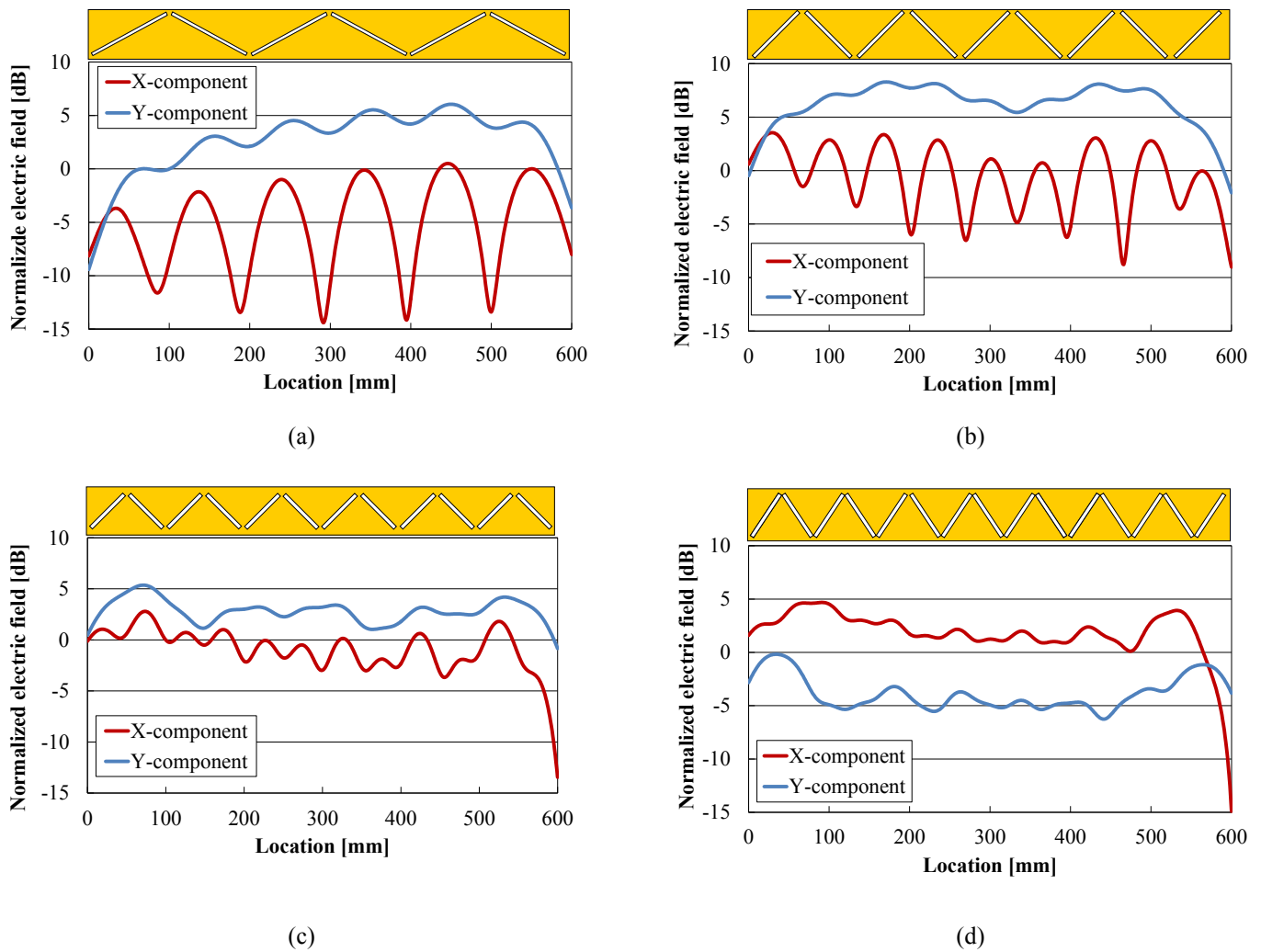

Fig. 5 Normalized electric field of changing the number of slots

(a) 6 slots type unit, (b) 9 slots type unit, (c) 12 slots type unit, (d) 15 slots type unit

IV. MEASUREMENT

In this chapter, the performance evaluation results of the prototype of cluttered tag detector are described. Fig. 6 shows the prototype unit of the cluttered tag detector. The prototype unit has 12 slots aperture, and each slots are set to 60 mm in length and 9 mm in width.

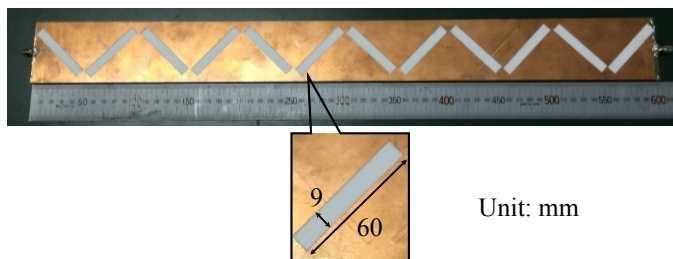

Fig. 6 The prototype unit

Figure 7 shows the configuration for the near electric field measurement. Small-shielded loop antenna is used for the measurement. Two directions of the electric field (X and Y components) are measured by changing the antenna angle. The measured electric fields on 50 mm away from the center line of the unit are also normalized with the measured electric field intensity 2 m away from the high-gain patch antenna. In Figure 8, X and Y components of the normalized measured electric field are compared with the calculated one. The radiation electric field strength with the prototype tag detector greatly declines unlike the prediction by the numerical analysis. Either of the slots are a homogeneous, symmetrical shape. However, the normalized electric field distribution in X and Y components are not corresponded each other. The reason is that, the standing wave distribution in this unit is thought to be not homogeneous though slot apertures are symmetry.

The radiation electric field reduces particularly at around 150mm ('Location' = 450 mm in Fig. 8) away from the 50Ω terminator. As reason of this, the electromagnetic radiation from the adjacent slots is presumed to cancel each other out. Fortunately, the identification test which uses actual tags has succeeded on the almost whole area of detector. However, it is necessary for equalizing the radiation level with the adopting asymmetric slot aperture. In the future, the second prototype tag detector will be fabricated while noting the composition material selection.

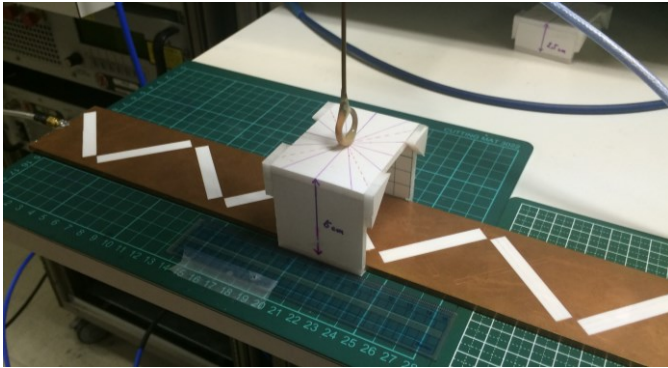

Fig. 7 Measurement condition

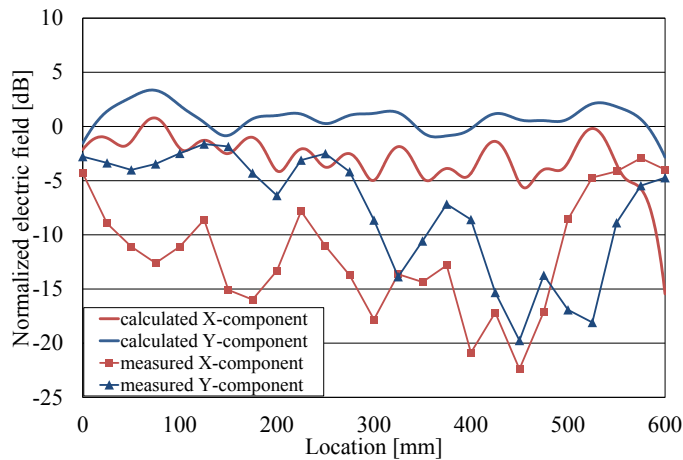

Fig. 8 Measured results and calculated results

V. CONCLUSION

In this paper, the detection system for UHF-RFID to detect nearby tags was proposed. The leaky coaxial cable that applied shielded type microstrip-line was adapted to the proposed system. The electromagnetic radiation increases as the slot width increases. The radiation level from the tags detector be deteriorated, if the slot length shorten even if the number of slots increases. The prototype unit's performance is evaluated by measurement.

Low-radiation point will be improved by changing the slot shape. The second prototype tag detector will be fabricated in near future. The multiple proposed units will be arrayed.

ACKNOWLEDGMENT

This work was supported under Grant-in-Aid for Scientific Research (C) 25420387.

REFERENCES

- [1] Gaetano Marrocco, "RFID Antennas for the UHF Remote Monitoring of Human Subjects," *IEEE TRANSACTIONS ON ANTENNA AND PROPAGATION*, Vol.55, No.6, June 2007.
- [2] *Radio Engineering*, New York: J. Wiley & Sons, 1980. Robert E. Collin and Franis J. Zucker, "Antenna Theory part II", chapter 20, McGraw-Hill Inc., 1969.
- [3] A. Taflov and M. E. Brodwin, "Numerical solution of steady state electromagnetic scattering problem using the time dependent Maxwell's equation," *IEEE Trans. On Microwave Theory and Techniques*, vol. 23, pp. 623-630, Aug. 1975.
- [4] Maiko Ochiai and Yoshinobu Okano, "Development of management system for gathered RFID-Tag with UHF band", *APMC*, 2009.