

# Relay Multiplexing Enhancement Using a Nonreciprocal Antenna Array

Rui Zang, Christophe Caloz, and Qingfeng Zhang,

**Abstract**—We introduce the concept of a *nonreciprocal* relay for multi-user communication in a cluttered environment. This relay is based on a nonreciprocal antenna array system that receives and transmits in *different* directions of space according to communication requirements. This relay features much higher gain than its conventional reciprocal and omnidirectional counterpart, where power is lost in undesired directions due to reciprocity. The proposed relay is demonstrated using in three-user downlink system design so as to receive and transmit uniquely in the appropriate directions.

## I. INTRODUCTION

A relay is an indirect communication link between transmitter and receiver when no direct link is available due to long distance or obstacles or when cooperative diversity is needed to enhance the quality of communication [1]-[2].

In a common scenario, the desired directions of the incoming and outgoing signals are not same. If high gain is required, one may use an antenna synthesized to exhibit directive lobes in the required different directions. However, in this case, the gain associated with each lobe is much less than the gain achievable by a single-beam antenna of the same size. A solution consists then in using different antennas for transmission and reception. However, using different antennas for transmission and reception will occupy more space and decrease the aperture efficiency.

We propose here the concept of a *nonreciprocal* relay, which exhibits the advantage of requiring *only one antenna* for the transmit and receive operations, hence reducing the complexity of the system. This relay is based on a nonreciprocal antenna array, which may itself be realized using a nonreciprocal *analog* feeding network, which essentially produces nonreciprocal phase shifts between the elements of the array and which may be using conventional ferrite technology or more recent planar magnetless transistor-based nonreciprocal systems [3]-[6].

The nonreciprocal relay can be used in any system which need a device to collect signal from one direction and re-transmit the signal to another direction, for example, the wireless control system, the satellite communication system and the mobile communication system. Comparing with the

digital phased array antenna, the array with nonreciprocal analog feeding network do not need extra control system to switch the feeding network when changing working state and has the possibility of full duplex. It is more suitable for the scenario that the reception and transmission directions are fixed.

## II. CONCEPT OF NONRECIPROCAL RELAY

### A. Basic Concept of Relay

Figure 1 shows the basic concept of the nonreciprocal relay in a cluttered environment. In such an environment, the transmitter must resort to a relay terminal to avoid obstacles (e.g. hills, tall buildings, etc.) so as to reach the receiver. Here the relay is equipped with a nonreciprocal antenna array system, which enables the following operation. The relay only “listens” in the directions of the transmitters and only “talks” in the direction of the receiver. Therefore, the relay is superior to a conventional relay in the sense that it uses only one antenna and is therefore less complex.

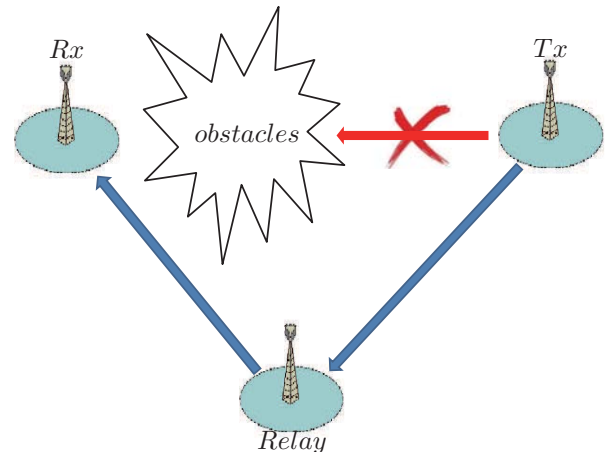

Fig. 1. Basic concept of *nonreciprocal* relay in a cluttered environment, where transmitter utilizes a relay terminal to avoid obstacles (e.g. hills, tall buildings, etc.) so as to reach the receiver. The relay terminal selectively (directively) receives the signals of the transmitter and re-transmits them to the receiver, using a nonreciprocal antenna array system.

### B. Multi-User Relay Communication System

Figure 2 shows the concept of the nonreciprocal relay for multi-user communication system. Typically, each user will use different frequencies for the uplink and downlink, which allows one to achieve different radiation patterns for the two

R. Zang is with Institute of Applied Physics, University of Electronic Science and Technology of China, ChengDu, China, e-mail: sdzangrui@gmail.com, .

C. Caloz is with Department of Electrical Engineering, Polytechnique de Montreal, QC H2T 1J3, Canada and also be with Electrical and Computer Engineering Department, King Abdulaziz University POB 80204, Jeddah 21589, Saudi Arabia email:christophe.caloz@polymtl.ca.

Q. Zhang is with the Department of Electrical and Electronics Engineering, South University of Science and Technology of China (SUSTC), Shenzhen 518055, China email: zhang.qf@sustc.edu.cn.

links. Moreover, different users use different frequencies in either the uplink or the downlink, which allows the relay to discriminate them via its synthesized radiation patterns.

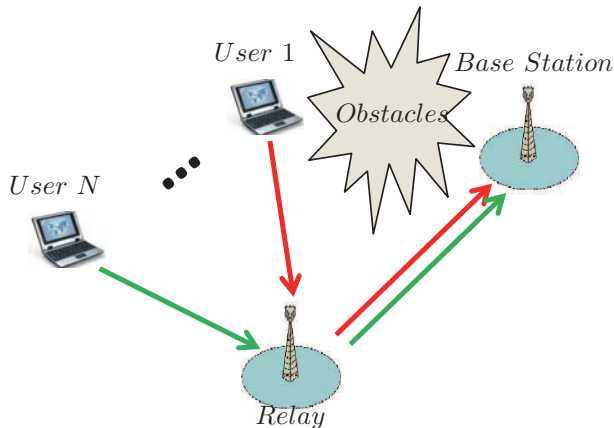

Fig. 2. Concept of *nonreciprocal* relay in a multi-user communication scheme in a cluttered environment. In the uplink, the relay terminal selectively (directly) receives the signals of the different users and re-transmits them to the base station, using a nonreciprocal antenna array system (different colours represent different frequencies); the relay terminal performs the opposite operation in the downlink (not shown for clarity).

### C. Nonreciprocal Phase Shifter using Circulators

In order to achieve the nonreciprocal antenna array, some nonreciprocal phase shifters are needed to build the nonreciprocal feeding network, which essentially produces nonreciprocal phase shifts between the elements of the array and which may be using conventional ferrite technology or more recent planar magnetless transistor-based nonreciprocal systems. Figure 3 shows two concepts of the nonreciprocal phase shifters using circulators, based on different phasers types.

## III. THREE-USER SYSTEM PROOF-OF-CONCEPT

Consider the scenario represented in Fig. 4. Three users are located at the azimuthal angles  $\phi_1 = 0^\circ$ ,  $\phi_2 = -30^\circ$  and  $\phi_3 = -60^\circ$ , respectively, while the base station is located at  $\phi = +45^\circ$ , relative to the relay. The azimuth angles, uplink frequencies and downlink frequencies of the different users are list in Tab. I.

TABLE I  
UPLINK AND DOWNLINK FREQUENCIES ASSIGNED TO THE USERS.

	user 1	user 2	user 3
azimuth angle	0	-30°	-60°
uplink frequency	2.9 GHz	2.8 GHz	2.7 GHz
downlink frequency	3.3 GHz	3.2 GHz	3.1 GHz

We choose for the antenna array of the relay terminal a 9-elements linear phased array with element spacing  $d = 40$  mm. The array is designed via array factor synthesis [7], whose

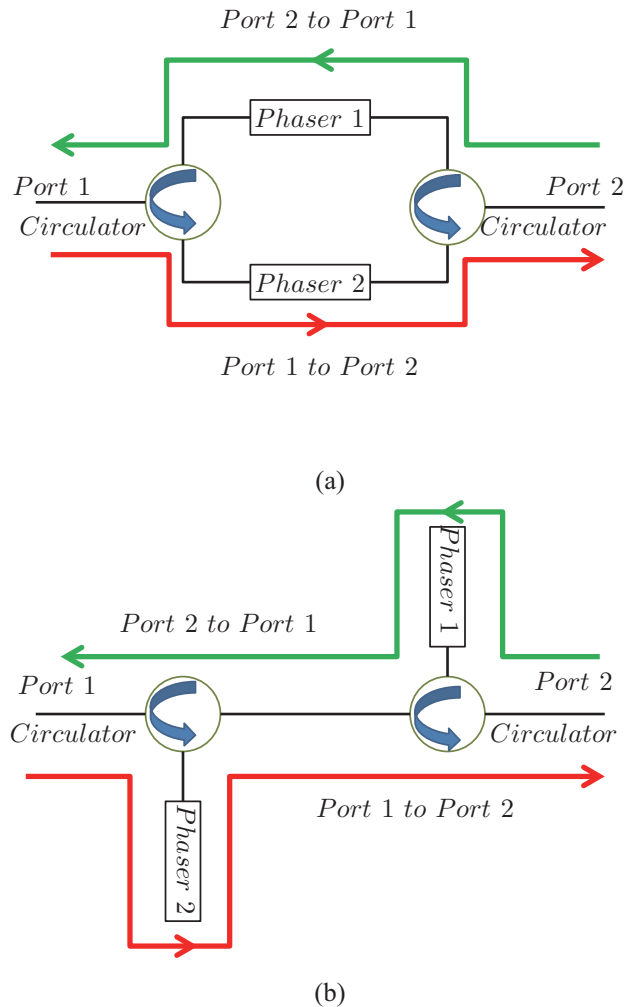

Fig. 3. Nonreciprocal phase shifter using circulators. The phaser 1 and phaser 2 have different group delays. (a) Using the transmission type phasers. (b) Using the reflection type phasers.

results provide the related phase shifts between the elements at each frequency. The array factor  $AF$  of a linear array is

$$AF(\phi) = \sum_{m=1}^N e^{j(m-1)(kd \sin \phi + \beta)} \quad (1)$$

where  $N$  is the number of the element,  $k$  is wave number,  $\beta$  is the phase difference between adjacent elements, and where the phase shift corresponding to radiation direction  $\phi_0$  is obtained as

$$\beta = -kd \sin \phi_0. \quad (2)$$

The resulting phase shifts, corresponding to Tab. I, are given in Tab. II, while the corresponding radiation patterns, obtained using (2), are plotted in Fig. 5.

## IV. PROSPECTIVE IMPLEMENTATION

The next step of the work will naturally consist in implementing the nonreciprocal antenna array exhibiting the synthesized phases, as in Tab. II for the example of the previous section. As the required shift phases are changed

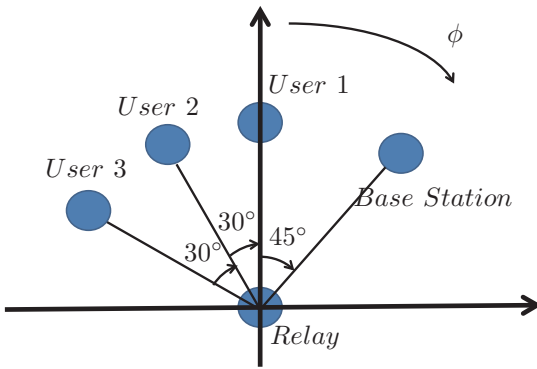

Fig. 4. Three-user scenario for the proof-of-concept.

TABLE II  
PHASE SHIFTS USED IN THE NONRECIPROCAL RELAY ARRAY.

	receive phase shift	transmit phase shift
2.7 GHz	1.9589	-1.5994
2.8 GHz	1.1729	-1.6587
2.9 GHz	0	-1.7179
3.1 GHz	-1.8364	2.2491
3.2 GHz	-1.8956	1.3404
3.3 GHz	-1.9549	0

according to the frequency, the phasers based on the coupling line structures will be used in the nonreciprocal relay [8]. The nonreciprocal phaser (NRP) will be consisted by circulators and phasers. The diagram of the relay is shown in Fig. 6. The group delay of NRP 1 will be designed to achieve the specific phase shifts for all frequencies according the request. And the group delay of NRP  $n$  will be  $n$  times of the NRP 1.

The fabricated nonreciprocal antenna array and the experimental results will be presented at the conference and reported elsewhere.

## REFERENCES

- [1] C. Hausl, and J. Hagenauer, "Relay Communication with Hierarchical Modulation", *IEEE Communications Lett.*, vol. 11, NO. 1, pp. 64–66, Jan. 2007.
- [2] J. N. Laneman, David N. C. Tse, and G. W. Wornell, "Cooperative Diversity in Wireless Networks: Efficient Protocols and Outage Behavior", *IEEE Trans. Inform. Theory*, vol. 50, NO. 12, pp. 3062–3080, Dec. 2004.
- [3] T. Kodera, D. L. Sounas, and C. Caloz, "Nonreciprocal Magnetless CRLH Leaky-Wave Antenna Based on a Ring Metamaterial Structure", *IEEE Antennas Wireless Propag. Lett.*, vol. 10, pp. 1551–1554, 2011.
- [4] T. Kodera, D. L. Sounas, and C. Caloz, "Artificial Faraday rotation using a ring metamaterial structure without static magnetic field", *Appl. Phys. Lett.*, vol. 99, no. 3, pp. 031 114:1C3, Jul. 2011.
- [5] D. L. Sounas, T. Kodera, and C. Caloz, "Electromagnetic modeling of a magnet-less non-reciprocal gyrotropic metasurface", *IEEE Trans. Antennas Propag.*, vol. 61, NO. 1, pp. 221–231, Jan. 2013.
- [6] T. Kodera, D. L. Sounas, and C. Caloz, "Magnetless non-reciprocal metamaterial (MNM) technology: application to microwave components", *IEEE Trans. Microw. Theory Tech.*, vol. 61, no. 3, pp. 1030C1042, Mar. 2013.
- [7] C. A. Balanis, *Antenna Theory Analysis And Design, 3rd ed.* John Wiley & Sons, Inc., 2005, pp. 290–304.
- [8] S. Gupta, Q. Zhang, L. Zou, L. J. Jiang, C. Caloz "Generalized Coupled-Line All-Pass Phasers", *IEEE Trans. Microw. Theory Tech.*, vol. 63, no. 3, pp. 1007C1018, Mar. 2015.

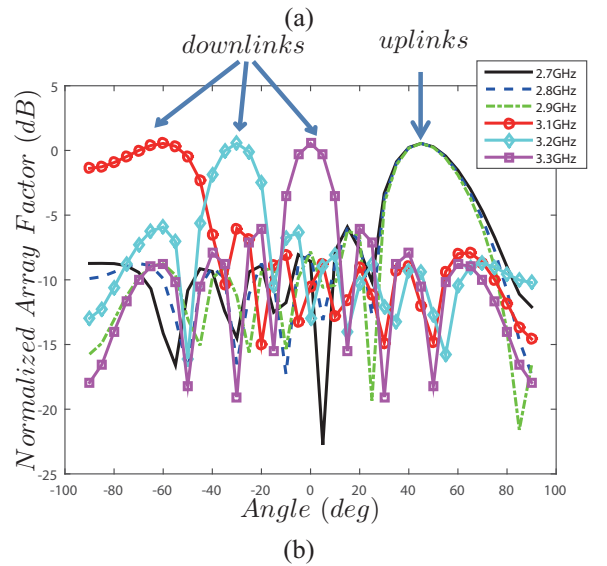
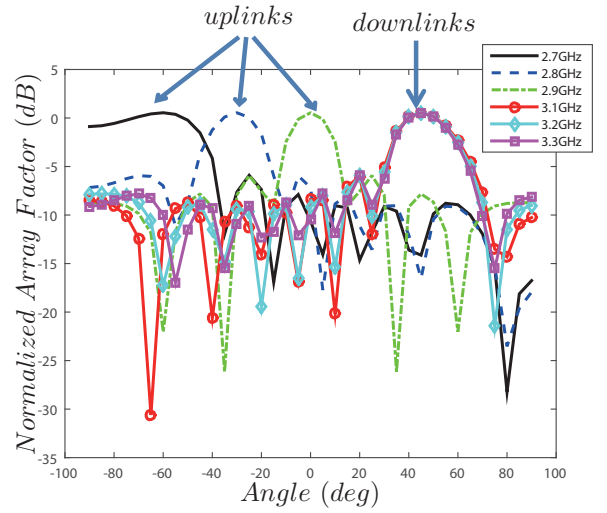

Fig. 5. Normalized array factor of the nonreciprocal relay antenna. (a) Receive patterns. (b) Transmit patterns.

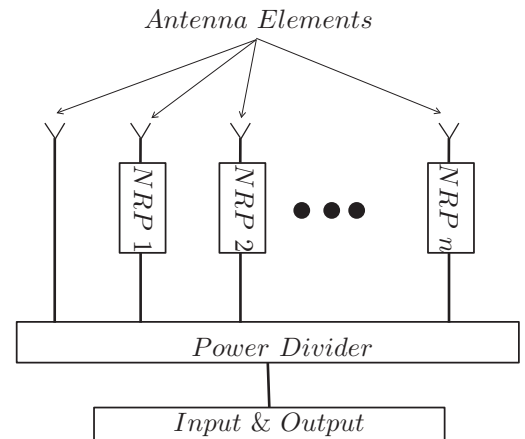

Fig. 6. Diagram for the nonreciprocal antenna array. The group delay of NRP 1 will be designed to achieve the specific phase shifts for all frequencies according the request. And the group delay of NRP  $n$  will be  $n$  times of the NRP 1.