

# Linear Precoding Techniques for 2-Hop MIMO Relaying

Byungwook Yoo<sup>1</sup>, Kyu Ha Lee<sup>2</sup>, Hyundo Kim<sup>3</sup>, and Chungyong Lee<sup>4</sup>

<sup>1,4</sup>Dept. of Electrical and Electronic Engineering, Yonsei University, Korea  
134, Shinchon-dong, Seodaemun-gu, Seoul 120-749, Korea

<sup>2,3</sup>Samsung Thales R&D Team

San 14-1, Nongseo-dong, Giheung-gu, Yongin-si, Gyeonggi-do 449-712, Korea

E-mail: {<sup>1</sup>randyoo, <sup>4</sup>clee}@csp.yonsei.ac.kr, {<sup>2</sup>kyuha.lee, <sup>3</sup>hyundo.kim}@samsung.com

**Abstract**—In this paper, we deal with the linear precoding techniques for 2-hop multiple-input multiple-output (MIMO) relaying, where limited feedback is available at source and relay nodes. Among the various linear precoding schemes, we utilize quantized precoding technique which is more implementable than precoding schemes with full feedback due to short feedback length. Based on quantized precoding technique, we propose the source and relay precoding matrix selection criterion in the given codebook to improve the bit error rate (BER) performance. As a result, the performance of the proposed algorithm exceeds that of open-loop MIMO relaying using optimum maximum likelihood (ML) receiver and Alamouti's scheme which is optimum open-loop orthogonal space-time block coding (OSTBC). Moreover, simulation results show that the proposed scheme has more diversity gain comparing with other open-loop schemes.

## I. INTRODUCTION

In recent years, relay network which stem from relay channel of information theory has received significantly interest due to coverage extension, low power consumption, and high data rate. As the relaying is flexible to apply various techniques, many researches about that are in progress such as channel capacity and performance analysis, resource allocation, cooperative diversity, multi-hop relaying, distributed MIMO, and so forth. Among the various research topics, MIMO relaying which is combined multiple antennas with relaying takes advantages of increasing the channel capacity and improving the reliability of data communication, simultaneously. Thus, diverse MIMO techniques can be applied in MIMO relaying.

Until recently, the main topic of MIMO relaying is increasing the channel capacity. For enhancing channel capacity, water-filling algorithm [1] which is the optimal precoding techniques for MIMO systems is applied for relay precoder [2]. Furthermore, the source and relay precoders design scheme to maximize the channel capacity is proposed for MIMO fixed relaying network [3]. There are also many BER minimizing schemes such as OSTBC [4] and linear dispersion codes (LDC) [5] for open-loop MIMO relaying and joint precoder and decoder design techniques to minimize mean square errors [6], transmit antenna subgroup selection scheme [7], and quantized precoding technique [8] for closed-loop MIMO systems. Among these techniques, the closed-loop techniques show better performance than open-loop techniques due to transmission using the channel state information (CSI).

However, the fact which transmitter knows exact CSI in full feedback systems means that infinitely many bits are required for feedback from receiver to transmitter. Thus, full feedback systems are not realistic but theoretical systems.

In this paper, we consider the implementable closed-loop MIMO relaying with partial feedback. For limited partial feedback systems, we utilize quantized precoding techniques to improve BER and to minimized the feedback load. We neglect the direct connection between the source and destination and assume slow and flat fading channel. By means of relaying scheme, we consider amplify-and-forward (AF) relaying, called non-regenerative relaying and decode-and-forward (DF) relaying, called regenerative relaying [9].

The remainder of this paper is organized as follows. Section 2 introduces the system and signal model of 2-hop closed-loop MIMO relaying and quantized precoder. In section 3, proposed precoder selection algorithm to minimize BER performance is described. Simulation results are discussed in section 4. Finally, section 5 concludes this paper and provides future works.

## II. 2-HOP CLOSED-LOOP MIMO RELAYING

In this section, we describe the system block diagram and signal model, then we briefly introduce the quantized precoding techniques for general closed-loop MIMO systems.

### A. System block diagram and signal model

Let us consider a 2-hop closed-loop MIMO relaying with  $M_t$  transmit antennas,  $M_r$  receive antennas, and  $N_s$  streams ( $N_s \leq \min\{M_t, M_r\}$ ) as illustrated in Fig. 1.  $N_s \times 1$  vector  $\mathbf{s}$  means the message symbol,  $\mathbf{F}_1$  and  $\mathbf{F}_2$  are  $M_t \times N_s$  source and relay precoding matrix which are selected by binary codebook index, and  $\mathbf{H}_1$  and  $\mathbf{H}_2$  are  $M_r \times M_t$  channel matrix which is spatially uncorrelated and whose elements are complex Gaussian random variables with  $CN(0, 1)$ .  $\mathbf{v}_1$  and  $\mathbf{v}_2$  are  $M_r \times 1$  independent additive complex Gaussian noise vector of relay and destination nodes, and distributed according to  $CN(0, N_0)$ .  $E_s$  and  $E_r$  are total transmit power at source and relay nodes, respectively. In this case, received symbol vector at relay node is given by

$$\mathbf{y}_r = \sqrt{\frac{E_s}{N_s}} \mathbf{H}_1 \mathbf{F}_1 \mathbf{s} + \mathbf{v}_1. \quad (1)$$

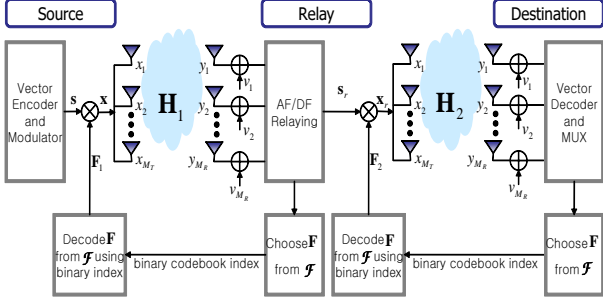

Fig. 1. System block diagram of the closed-loop MIMO relaying.

The transmit symbol vector at relay node can be changed by relaying scheme such as AF and DF [9]. Thus, received symbol vector at destination node can be written as

$$\mathbf{y}_d^{DF} = \sqrt{\frac{E_r}{N_s}} \mathbf{H}_2 \mathbf{F}_2 \hat{\mathbf{s}} + \mathbf{v}_2, \quad (2)$$

$$\mathbf{y}_d^{AF} = \beta \sqrt{\frac{E_s}{N_s}} \mathbf{H}_2 \mathbf{F}_2 \mathbf{H}_1 \mathbf{F}_1 \mathbf{s} + \beta \mathbf{H}_2 \mathbf{F}_2 \mathbf{v}_1 + \mathbf{v}_2, \quad (3)$$

where  $\mathbf{y}_d^{DF}$  and  $\mathbf{y}_d^{AF}$  are received symbol vector at destination node which are relayed by DF and AF relaying scheme, respectively and  $\beta$  is the power amplifying factor by AF relaying [9] and is represented as

$$\beta = \sqrt{\frac{E_r}{E\{|\mathbf{y}_r|^2\}}}, \quad (4)$$

where  $E\{\cdot\}$  denotes the expectation operation and  $|\cdot|$  means the vector norm.

### B. Quantized Precoding

Quantized precoding technique is partial CSI scheme to reduce amount of feedback. In quantized precoding, the transmitter and receiver have the same codebook,  $\mathfrak{S}$  which is the set of  $M_t \times N_s$  unitary precoding matrices. After the transmitter sends pilot symbol, the receiver estimates the current channel matrix and finds the codebook index of precoding matrix which shows the best performance among the whole precoding matrices of the codebook,  $\mathfrak{S}$ , then the receiver transmits the codebook index to the transmitter. From the received feedback information, the transmitter performs precoding the transmit symbol vector, then precoded symbol vectors are transmitted.

Now, we discuss the precoding matrix selection criteria from given codebook with size  $N$  (The number of feedback bits are given by  $\lceil \log_2 N \rceil$ ). Let us consider MIMO quantized precoding system depicted in left half of Fig. 1. Then, (1) will be the received symbol vector at the receiver. From (1), we can find message symbol vector,  $\mathbf{s}$  using conventional MIMO receiver such as zero-forcing (ZF), minimum mean square error (MMSE), vertical Bell labs space time (V-BLAST), and maximum likelihood (ML) receiver. Among these receivers, we consider only linear ZF receiver due to low complexity. The linear ZF receiver applies an  $N_s \times M_t$  matrix,  $\mathbf{G}$  which

is chosen according to least square (LS) criterion. The ZF receiver is represented by

$$\mathbf{G}_{ZF} = (\mathbf{H}\mathbf{F}_i)^\dagger, \quad (5)$$

where  $(\cdot)^\dagger$  denotes the matrix pseudo-inverse operation and  $i$  represents the index of the codebook. The performance of the ZF receiver is represented by a function of post signal-to-noise-ratio (SNR) for each substream. The post-SNR of the  $k$ th sub stream for the ZF receiver is written by

$$\eta_{k,i}^{ZF} = \frac{E_s}{N_s N_0 [\mathbf{F}_i^H \mathbf{H}^H \mathbf{H} \mathbf{F}_i]_{k,k}^{-1}}, \quad (6)$$

where  $k$  is index of substreams,  $\mathbf{A}_{k,k}^{-1}$  denotes  $(k, k)$  entry of  $\mathbf{A}^{-1}$ , and  $(\cdot)^H$  means matrix conjugate transposition. Minimizing a bound on the average probability of error, the minimum sub stream SNR must be maximized [7]. Therefore, codebook index selection criteria for the ZF receiver are given by

$$i^* = \arg \max_{1 \leq i \leq N} \min_{1 \leq k \leq N_s} \eta_{k,i}^{ZF}, \quad (7)$$

where  $i^*$  is optimal value of codebook index. It was shown that the minimum post SNR for ZF receiver can be bounded using Rayleigh-Ritz theorem [7],

$$\eta_{min,i}^{ZF} = \min_{1 \leq k \leq N_s} \eta_{k,i}^{ZF} \geq \frac{E_s}{N_s N_0} \sigma_{min}^2 \{\mathbf{H}\mathbf{F}_i\}, \quad (8)$$

where  $\sigma_{min}$  means the minimum singular value of the given matrix. Using minimum singular value bound, the minimum singular value selection criterion (MSV-SC) can be written as

$$\mathbf{F} = \arg \max_{\mathbf{F}_i \in \mathfrak{S}} \sigma_{min} \{\mathbf{H}\mathbf{F}_i\}. \quad (9)$$

### III. PRECODER SELECTION ALGORITHM

In this section, we propose source and relay precoder selection algorithm to minimize the BER in 2-hop MIMO relaying. In our system, ZF receiver is used for MIMO detector to minimize computational complexity.

The system structure for MIMO DF relaying looks like concatenated two MIMO systems. In other words, the source and relay nodes are considered as one MIMO transceiver pair, and the relay and destination nodes are regarded as the other MIMO transceiver pair. Therefore, conventional quantized precoding scheme can be used for MIMO DF relaying. The source precoder is selected by codeword index from the relay node and the relay one is chosen by feedback of the destination node using MSV-SC. Thus, the source and relay precoders for the MIMO DF relaying by using MSV-SC are determined by conventional codeword selection criterion in (9), and they are given by

$$\begin{aligned} \mathbf{F}_1 &= \arg \max_{\mathbf{F}_i \in \mathfrak{S}} \sigma_{min} \{\mathbf{H}_1 \mathbf{F}_i\}, \\ \mathbf{F}_2 &= \arg \max_{\mathbf{F}_j \in \mathfrak{S}} \sigma_{min} \{\mathbf{H}_2 \mathbf{F}_j\}, \end{aligned} \quad (10)$$

where  $\mathbf{F}_1$  and  $\mathbf{F}_2$  denote the source and relay precoding matrix, respectively. In DF relaying, joint precoding matrix

selection scheme cannot be utilized due to symbol detection at the relay node. Thus, individual precoding matrix selection scheme only allows.

In AF relaying comparing with DF relaying, various selection criteria can be applied to minimized BER. Especially, if the destination node knows not only the effective channel but also the individual channel,  $\mathbf{H}_1$  and  $\mathbf{H}_2$ , joint precoder selection scheme can be utilized at the destination node. In this paper, we propose three codebook selection schemes for MIMO AF relaying.

First scheme is the same to precoder selection criteria for MIMO DF relaying shown in (10) (DF-SC). The relay node transmits the codeword index which maximizes the minimum singular value of effective channel,  $\mathbf{H}_1 \mathbf{F}_i$  to the source node and the destination node sends the codebook index that maximizes the minimum singular value of effective channel,  $\mathbf{H}_2 \mathbf{F}_j$  to the relay node. It means that the source precoder is selected to minimize the BER of transmitted symbol vector,  $\mathbf{s}$  and the relay precoder is chosen to minimize the BER of relaying symbol vector,  $\beta \mathbf{y}_r$ . Thus, it is simplest way to find the precoding matrix, however performance is degraded because the relay precoder does not minimize the BER of transmitted symbol vector, but minimize the BER of noisy relaying symbol vector.

Second method is the precoder selection scheme using effective channel (Eff-SC). From (3), the effective channel of the received signal at the destination node in MIMO AF relaying is written as follows:

$$\mathbf{H}_{i,j}^{(eff)} = \beta \sqrt{\frac{E_s}{N_s}} \mathbf{H}_2 \mathbf{F}_j \mathbf{H}_1 \mathbf{F}_i. \quad (11)$$

From (11), the source and relay precoders can be determined by joint searching to maximize the minimum singular value of the effective channel at the destination node, if the destination node knows both effective channel and individual channel. Thus, Eff-SC is represented by

$$\{\mathbf{F}_1, \mathbf{F}_2\} = \arg \max_{\mathbf{F}_i, \mathbf{F}_j \in \mathfrak{S}} \sigma_{\min} \mathbf{H}_{i,j}^{(eff)}, \quad (12)$$

where the index  $i$  and  $j$  denote the source and relay codebook index, respectively. Therefore, Eff-SC is joint precoder selection technique and shows the better performance than DF-SC due to considering effective channel. However Eff-SC has more computational complexity because of  $N^2$  effective channel calculations, and  $N^2$  minimum singular value findings and comparisons comparing with each  $2N$  computations for DF-SC. Moreover it does not consider effective noise from (3), thus it causes performance degradation.

Lastly, we consider the output vector of ZF receiver,  $\mathbf{z}$  as follows:

$$\mathbf{z} = \mathbf{s} + \sqrt{\frac{N_s}{E_s}} \tilde{\mathbf{H}}_{i,j}^\dagger \mathbf{H}_2 \mathbf{F}_j \mathbf{n}_1 + \sqrt{\frac{N_s}{\beta^2 E_s}} \tilde{\mathbf{H}}_{i,j}^\dagger \mathbf{n}_2, \quad (13)$$

where  $\tilde{\mathbf{H}}_{i,j}$  means effective channel which is given by

$$\tilde{\mathbf{H}}_{i,j} = \mathbf{H}_2 \mathbf{F}_j \mathbf{H}_1 \mathbf{F}_i. \quad (14)$$

From (13) and (14), the post SNR per substream can be considered as the selection criterion (SNR-SC) and is written by

$$\eta_{k,i,j}^{ZF} = \frac{\beta^2 E_s / N_0 N_s}{\beta^2 \left[ \tilde{\mathbf{H}}_{i,j}^\dagger \mathbf{H}_2 \mathbf{F}_j \mathbf{F}_j^H \mathbf{H}_2 \tilde{\mathbf{H}}_{i,j}^\dagger \right]_{k,k} + \left[ \tilde{\mathbf{H}}_{i,j}^H \tilde{\mathbf{H}}_{i,j} \right]_{k,k}^{-1}}. \quad (15)$$

If the number of substreams,  $N_s$  is equal to the number of receive antennas,  $M_r$ ,  $\tilde{\mathbf{H}}_{i,j}$  will be square matrix, the matrix pseudo-inverse operation will change the matrix inversion operation. Therefore, (15) can be reduced as follows:

$$\eta_{k,i,j}^{ZF} = \frac{\beta^2 E_s / N_0 N_s}{\beta^2 \left[ (\mathbf{H}_1 \mathbf{F}_i)^H (\mathbf{H}_1 \mathbf{F}_i) \right]_{k,k}^{-1} + \left[ \tilde{\mathbf{H}}_{i,j}^H \tilde{\mathbf{H}}_{i,j} \right]_{k,k}^{-1}}. \quad (16)$$

From (16), the SNR-SC is scheme which maximizes the minimum post SNR among the substreams and is expressed as

$$\{\mathbf{F}_1, \mathbf{F}_2\} = \arg \max_{\mathbf{F}_i, \mathbf{F}_j \in \mathfrak{S}} \min_{1 \leq k \leq N_s} \eta_{k,i,j}^{ZF}. \quad (17)$$

SNR-SC which is considered the post SNR shows the best performance, but it has much computational complexity due to  $N^2 + N$  matrix inverse operations.

In joint precoder selection criteria such as Eff-SC, SNR-SC, codeword indexes are determined at the destination node. Though we assume that the source node cannot communicate the destination node, it is possible if the destination node sends the source and the relay precoder index to the relay node and the relay node retransmits the source precoder index to the source node.

#### IV. SIMULATION RESULTS

In this section, we evaluate the performance of the proposed precoder selection schemes for MIMO DF and AF relaying. To evaluate the performance of the proposed schemes, we consider  $4 \times 2$  MIMO relaying with 2 streams ( $M_t = 4$ ,  $M_r = N_s = 2$ ) and use 3 and 6 bits codebook ( $N=8$ , or  $N=64$ ). Comparing with the performance of the proposed algorithms, we also evaluate the performance of the open-loop MIMO relaying which are detected by ML receiver and MIMO DF relaying based on Alamouti's scheme [10]. Fig. 2 and Fig. 3 show the BER performances of the 3bits codebook and 6bits codebook, respectively. From the results, we confirmed that the size of codebook determine the performance of quantized precoder. The more size of codebook is large, the more diversity gain is generated due to selection diversity. Moreover, we discovered that diversity gain of the proposed codebook selection schemes is larger than two, which is the maximum diversity gain of  $2 \times 2$  MIMO systems with ML receiver. Of course, that is smaller than four, which is the maximum diversity gain of  $2 \times 2$  OSTBC scheme. This fact tells us that the proposed schemes are useful scheme to enhance the BER performance and diversity gain because of partial feedback and selection diversity.

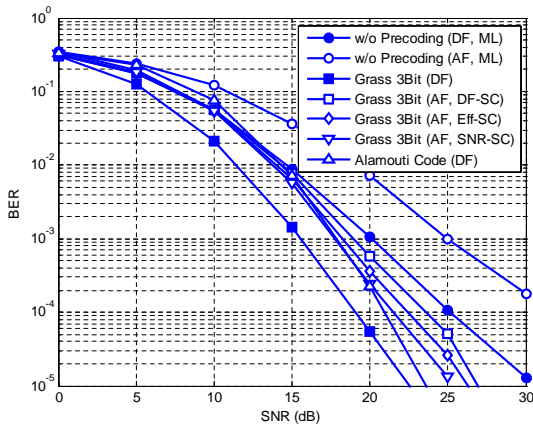

Fig. 2. The BER performances of the 3bits codebook.

Generally, the performance of the proposed algorithm for MIMO DF relaying was better than that for MIMO AF relaying about 1~2dB at BER=10<sup>-4</sup> because additive noise at the relay node is amplified. However, if the size of codebook is large, the performance gap is decreased. Furthermore, diversity gain of AF relaying is rather better than that of DF relaying due to joint selection method. On the 3bits codebook case, the proposed AF precoder selection schemes got 4~6 dB SNR degradation at BER=10<sup>-4</sup> over the DF relaying due to noise enhancement and small size of codebook and on the 6bits codebook case, the proposed schemes have 1~3 dB SNR loss at the BER=10<sup>-4</sup> over the DF relaying. However, diversity gain of the proposed algorithms exceeds that of 6bits DF relaying scheme. Thus, the performance of the proposed AF relaying precoding algorithm takes advantage of the performance gain at high SNR region.

## V. CONCLUSIONS

In this paper, we proposed the linear precoding techniques to enhance the BER performance of MIMO DF and AF relaying. Especially, we utilized the quantized precoding scheme which use low feedback bits and proposed the precoding matrix selection criteria for the source and relay node. In MIMO DF relaying, individual MSV-SC was only proposed due to symbol detection at the relay node. In MIMO AF relaying, individual and joint selection scheme were proposed. Among the three proposed selection schemes for MIMO AF relaying, SNR-SC showed the best performance, however it had much computational complexities. By computer simulations, we have shown that the proposed precoder selection algorithms get the higher diversity gain than the optimal open-loop MIMO relaying due to using CSI from partial feedback and selection diversity from codebook. If the size of codebook is more large than 6 bits, we predict that the performance gap between DF and AF relaying is much smaller.

In future works, we will study the algorithm to improve the performance of quantized precoder with low bits than 3bits, because signaling overhead, in fast fading channel,

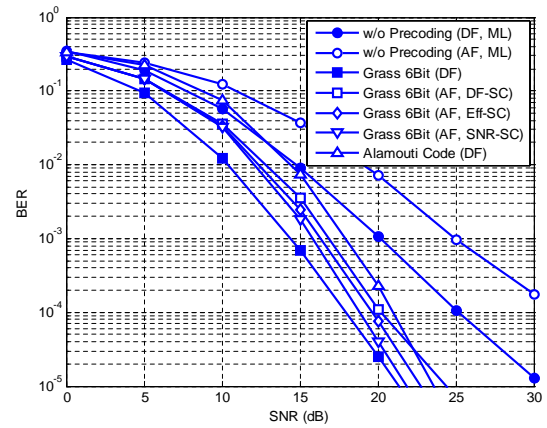

Fig. 3. The BER performances of the 6bits codebook.

is more large due to often finding proper source and relay precoder. Moreover we will find more computation efficient algorithm for SNR-SC which requires  $N^2 + N$  matrix inversion operations. Comparing with MIMO DF relaying which performs symbol demapping, decoding, re-encoding, symbol re-mapping, and re-transmission, MIMO AF relaying is more implementable. Thus, the performance of MIMO AF relaying must be comparable with that of MIMO DF relaying. As current SNR-SC requires much computational complexities, computation optimized algorithm for SNR-SC is required.

## REFERENCES

- [1] T. Cover and J. Thomas, *Elements of Information Theory*, Wiley, New York, 1991.
- [2] O. Munoz-Medina, J. Vidal, and A. Agustin, "Linear Transceiver Design in Nonregenerative Relays with Channel State Information," *IEEE Trans. Signal Process.*, vol. 54, Jun. 2007.
- [3] C.-B. Chae, T. Tang, R. W. Heath Jr., and S. Cho, "MIMO Relaying with Linear Processing for Multiuser Transmission in Fixed Relay Networks," *IEEE Trans. Signal Process.*, vol. 56, no. 2, pp. 727-738, Feb. 2008.
- [4] S. Yiu, R. Schober, and L. Lampe, "Distributed Space-Time Block Coding," *IEEE Trans. Commun.*, vol. 54, no. 7, pp. 1195-1206, Jul. 2006.
- [5] Y. Jing and B. Hassibi, "Distributed Space-Time Codes in Wireless Relay Networks," *IEEE Trans. Wireless Commun.*, vol. 5, issue 12, pp. 3524-3536, Dec. 2006.
- [6] H. Sampath and A. J. Paulraj, "Joint Transmit and Receiver Optimization for High Data Rate Wireless Communication Using Multiple Antennas," in *Proc. Asilomar Conf. Signals, Systems, and Computers*, pp. 215-219, Nov. 1999.
- [7] R. W. Heath Jr., S. Sandhu, and A. J. Paulraj, "Antenna Selection for Spatial Multiplexing Systems with Linear Receivers," *IEEE Commun. Lett.*, vol. 5, no. 4, pp. 2276-2280, Apr. 2001.
- [8] D. J. Love and R. W. Heath Jr., "Limited Feedback Unitary Precoding for Spatial Multiplexing Systems," *IEEE Trans. Inf. Theory*, vol. 51, no. 8, pp. 2967-2976, Aug. 2005.
- [9] J. Laneman, D. Tse, and G. Wornell, "Cooperative Diversity in Wireless Networks: Efficient Protocols and Outage Behavior," *IEEE Trans. Inf. Theory*, vol. 50, pp. 3026-3080, Dec. 2004.
- [10] S. M. Alamouti, "A Simple Transmit Diversity Technique for Wireless Communications," *IEEE J. Select. Areas Commun.*, vol. 16, pp. 1452-1458, Oct. 1998.