

# Packet-Aware Transport System to Effectively Apply Ethernet Services to Service Provider Networks

Jiwook Youn<sup>1</sup> and Byungjun Ahn<sup>1</sup>

1: Electronics and Telecommunications Research Institute, 138 Gajeongno, Yuseong-gu, Daejeon, 305-700, KOREA  
TEL: +82-42-860-1214, FAX: +82-42-860-6858, E-mail: [younjw@etri.re.kr](mailto:younjw@etri.re.kr)

## Abstract

We propose and experimentally demonstrate a packet-aware transport system that effectively supports both Ethernet services and legacy TDM service over existing SONET/SDH based service provider networks. The proposed transport system has a connection-oriented configuration operating packet switch basis and provides L2 VPN service and premium multimedia service based on MPLS protocol. Through the use of VCGs provisioned by centralized control plane, we can effectively provide QoS guaranteed Ethernet service, leased line service, and best-effort service in a single link. The SONET/SDH based OAM and protection scheme ensure Ethernet services of high reliability required in the broadband transport networks.

Keywords: Ethernet, Transport networks, TDM/Data convergence, Quality of service

## 1. Introduction

Legacy service provider networks have designed to provide TDM (Time Division Multiplexing) services like voice service with high performance and low latency. However, current service provider networks are changing by accelerating demand for Ethernet services representing data traffic. Ethernet has been gaining more interest from not only data service provider but also telecom service provider because of low cost, flexibility, and scalability in bandwidth. Therefore properties of service provider networks are changing to burst data network, finer granularity and scalability and trying to apply Ethernet to transports network like metro network and carrier-class network. However, to use Ethernet for WAN (Wide Area Network) deployment in service provider networks, we should solve problems like reliability, fast protection and restoration, end-to-end management, quality of service based on flow [1-2]. Ethernet transporting technologies have been studying to effectively support dramatically increasing data traffic while maintain the infrastructure of the legacy service provider networks [3-4]. Transporting Ethernet services over pure

switched Ethernet network is the most simplest connection-less architecture. The pure switched Ethernet solution has advantages such as low cost, flexibility and simplicity. But the lack of reliability, protection scheme and guarantee bandwidth per flow, it makes Ethernet difficult to use in the carrier-class networks. Moreover change legacy service provider networks based on SONET/SDH network to pure switched Ethernet network would mean building an expensive overlay network parallel to the extensive existing SONET/SDH infrastructure. Therefore to overcome a defect of pure switched Ethernet network, Ethernet is combined with IP/MPLS technology. IP routing protocol can be used to rapid resilient instead of STP (Spanning Tree Protocol). Connection oriented configuration based on MPLS technology provides QoS (Quality of Service) and reliability based on flow. However, IP/MPLS based transport network also doesn't support protection switching time of 50 ms required in the carrier-class transport network and lacks the OAM scheme. Therefore, SONET/SDH based TDM/data convergence transport networks are proposed to support dramatically increasing data traffic while maintain the infrastructure of the legacy service provider networks.

In this paper, we propose and experimentally demonstrate a packet-aware transport system (QSS120: QoS guaranteed Service Switch which has 120 Gbps capacity) that supports both Ethernet services and legacy TDM services in the service provider networks, simultaneously. The proposed packet-aware transport system has a connection oriented configuration operating packet switch basis. QSS120 system supports both shared VCG (Virtual Concatenation Group) and dedicated VCG. Through the use of VCGs provisioned by centralized control plane, we can effectively provide QoS guaranteed Ethernet services, leased line service, and best-effort service in a single link over existing transport networks. Traffic is processed with a packet basis instead of TDM format but SONET/SDH technology provides performance monitoring, OAM, and protection. Connection-oriented Ethernet transport tunnels disable unpredictable functions such as MAC (media access control) learning, spanning tree protocol, and broadcast of unknown to allow Ethernet to be

managed like circuits. QSS120 system combines the advantages of Ethernet like scalability, efficiency, and flexibility with the determinism, reliability, and manageability inherent in SONET/SDH networks, but at a much lower cost. QSS120 system can use both Ethernet and SONET/SDH as a physical layer and provides RPR over SONET/SDH based on EoS technology.

## 2. Configuration

Reference [5] shows a functional block diagram of QSS120 system [5]. QSS120 system is composed of Ethernet line card, SDH/EoS line card, POS line card, switch fabric, and main processor card. QSS120 system is TDM/data convergence system operating packet switch basis and provides both L2 VPN service and premium multimedia service. QSS120 system has a centralized control plane to create end-to-end connection with VCGs. Figure 1 shows a frame format supporting in the QSS120 system. If SDH is used as a physical layer, SDH overhead and GFP/PPP header with a dotted line are added to the frame. The frame format of figure 1(a) has 1-label stacking configuration with 30 bytes overhead. Figure 1(b) shows the frame format of 2-label stacking with 52 bytes overhead. QSS120 system can support both shared VCGs and dedicated VCGs on the single link, simultaneously. VCGs provide end-to-end connectivity as a virtual tunnel which contains traffic with same destination. Figure 2 is an example of VCG partitioning according to service types. Shared VCGs support traffic add/drop function at the layer 2 and statistical multiplexing function. Dedicated VCGs provide layer 1 add/drop function. VCG is composed of VCs (VC-3/4) having differential flow profile. VC transports Ethernet frames classified by flow.

For example, shared VCG 1 can transport CIR (Committed Information Rate) traffic like voice service, real time video service with strictly bounded delay and jitter. Shared VCG 2 can transport CIR traffic and EIR (Excess Information Rate) traffic, simultaneously. EIR traffic represents services which have properties of reuse, non-real time, and guarantee of minimum bandwidth. Shared VCG 3 can transport best-effort traffic. If the congestion occurs in the VCGs supporting EIR traffic, the bandwidth is controlled per flow by shaping algorithm based on priority bit of VLAN tag or DSCP/EXP field without affecting CIR traffic. The bandwidth of CIR traffic is strictly controlled by QoS profile. The bandwidth of VCG is controlled dynamically by LCAS (Link Capacity Adjustment Scheme) function. LCAS allows virtual containers to be added and removed from VCGs in response to packet data transport needs without affecting ongoing

data transmission. VCG transporting best-effort service traffic can be used as protection channel for CIR service

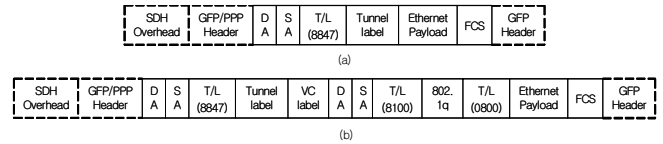

Fig.1. Frame format for (a) premium multimedia service and (b) L2 VPN service

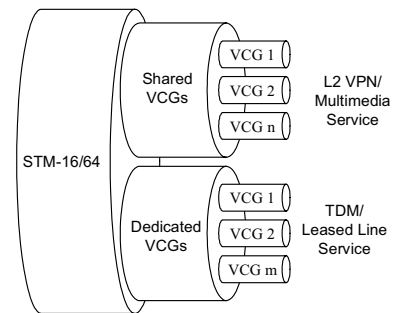

Fig.2. VCG partitioning based on service types

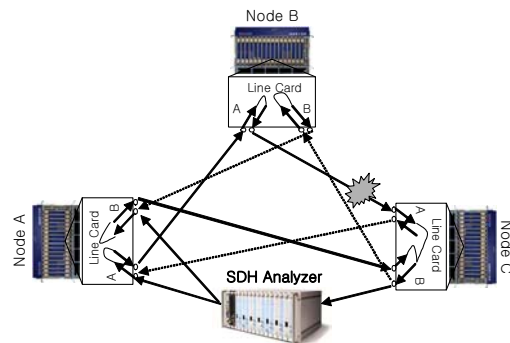

Fig.3. Experimental setup to evaluate QSS120 system

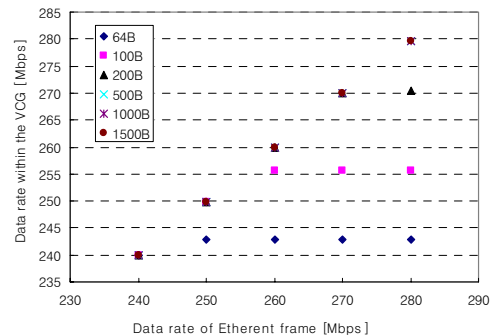

Fig.4. Data rate against Ethernet frame size

### 3. Experiment and Results

Figure 3 shows the experimental setup to evaluate performance of QSS120 system. Experimental setup was composed of packet/SDH analyzer and three QSS120 systems that construct SDH ring network having working ring (A-A) and protection ring (B-B). The link consisted of eight VCGs with 311 Mbps capacity. VCG consisted of six VC-3s (VC-3-6v) with differential flow profile. The maximum transmission bandwidth of VCG was calculated and measured according to the size of Ethernet frame. Table 1 shows the encapsulation efficiency of Ethernet frame according to service types and maximum transmission bandwidth of VCG (VC-3-6v) for multimedia service. Ethernet frame includes only MAC header except IFG and PA/SFD. From table 1, L2 VPN service has the lowest encapsulation efficiency because of adding overhead of 52 bytes, on the other hand multimedia service with overhead of 30 bytes has the best encapsulation efficiency when Ethernet frame size is less than 200 bytes. Figure 4 shows the experimental result of maximum transmission rate of VCG against Ethernet frame size for multimedia service. QSS120 system can manage Ethernet frames flow basis by the centralized control plane to guarantees bandwidth of each channel without affecting adjacent channel under congestion condition. Table 2 shows the experimental result of bandwidth control per VCG based on QoS profile. We established two shared VCGs between node A and node C of figure 3. VCG 1 represented a virtual tunnel to transport traffic with CIR, on the other hand VCG 2 represented a virtual tunnel for best effort service. Ethernet frame had a fixed size of 64 bytes. The bandwidth of VCG 1 and VCG 2 was 240 Mbps and 311 Mbps, respectively. The data rate of Ethernet frame inputted to VCG 2 was changed 240 Mbps to 270 Mbps. From figure 4, the maximum transmission rate was 242.9 Mbps for the Ethernet frame with fixed size of 64 bytes. If Ethernet frame inputs VCG 2 in excess of bandwidth, the transmission rate of VCG 2 is increased by 242.9 Mbps, and then excess of Ethernet frame is dropped. From table 2, if the bandwidth wasn't controlled by QoS basis independently, the bandwidth of VCG 1 was decreased in proportion to excess of bandwidth of VCG 2. However, under the condition of bandwidth control, the bandwidth of VCG 1 maintained initial setup value without effect an excess traffic of VCG 2. For the experiment of UPSR protection, SDH frame (STM-16) was generated by SDH analyzer and inputted both working port and protection port of node A by using optical coupler (50:50). SDH analyzer was connected with protection link of node C to measure restoration time and test protection switching function. Traffic was on the solid line but dotted line. We cut the working link between node B and node C to occur LOS.

The restoration time from link fail ( $T_R$ ) was measured about 22 ms from equation 1. The detection time of link failure was about 60  $\mu$ s and manual switching time was about 4  $\mu$ s.

$$T_R = \frac{\text{Number of lost frame}}{\text{Frame rate}} \quad [1]$$

Table 1. Encapsulation efficiency of service types

Ethernet Frame size (Byte)	Ethernet Service (w/o VLAN)	L2 VPN (w/ VLAN)	Multimedia (w/o VLAN)	
		VC-3/VC-4	VC-3/VC-4	VC-3-6v (Mbps)
64	76.19	66.30/66.81	80.46/81.09	250.28
100	83.33	74.16/74.73	85.31/85.97	265.37
200	90.90	86.97/87.64	90.14/90.84	280.39
500	96.15	90.18/90.88	93.31/94.03	290.25
1000	98.03	92.78/93.50	94.42/95.15	293.69
1500	98.68	93.68/94.41	94.79/95.53	294.85

Table 2. The experimental result of bandwidth control

Bandwidth control		Input data rate of VCG 2 (Mbps)			
		240	250	260	270
Non-apply	VCG 1	239.9	232.4	229.0	216.3
	VCG 2	239.9	242.9	242.9	242.9
Apply	VCG 1	239.9	239.9	239.9	239.9
	VCG 2	239.9	242.9	242.9	242.9

### 4. Conclusion

In this paper, we have discussed how to employ effectively Ethernet services to service provider networks. Currently, Ethernet networks have been increasing the region in the metro networks and carrier-class networks. However, it has many limitations in terms of cost and technology to establish Ethernet networks. To solve these problems with current technologies, we propose and experimentally demonstrate a packet-aware transport system. Proposed packet-aware transport system (QSS120) effectively supports both Ethernet services and legacy TDM services without changing the infrastructure of current service provider networks. The QSS120 system has a connection-oriented configuration operating packet switch basis. Through the use of VCGs provisioned by centralized control plane, we can effectively provide QoS guaranteed Ethernet services, TDM services, and best-effort service via the same link. QSS120 system can provide all kind of Ethernet services and ensures the differentiated QoS for Ethernet service without changing the infrastructure of current service provider networks.

## References

- [1] Joe Mocerino, "Carrier Class Ethernet Service Delivery Migrating SONET to IP & Triple Play Offerings," OFC/NFOEC, JThB97, 2006.
- [2] Thomas S. Afferton et al., "Packet-Aware Transport for Metro Networks," IEEE Commu. Mag., pp.120-127, 2004.
- [3] Xiaoming He et al., "Transporting Metro Ethernet Service over Metropolitan Area Networks," in Proc. of IEEE Conf. on SUTC, vol. 2, 2006.
- [4] Dirceu Cavendish, et al., "New Transport Service for Next-Generation SONET/SDH Systems," IEEE Commu. Mag., pp.80-87, 2002.
- [5] Hong Ju Kim, et al., "The Role of Ethernet over SDH in QoS Switch/Router," Proc. on ICACT, 2006.