

A high compression ratio image coding for frame memory reduction in LCD overdrive

Jun Wang, Kyeongyuk Min, Jongwha Chong

College of electrical and computer engineering, Hanyang University, Seoul, Korea

E-mail: jwang@hanyang.ac.kr, kymin@hanyang.ac.kr, jchong@hanyang.ac.kr

Abstract: In this paper, we developed a high compression ratio image coding (HCRIC) for frame memory reduction in LCD overdrive to reduce motion blur. We have used the characteristic of human visual system (HVS) to separate the luminance data and chrominance data, firstly. And then use different methods to compress them. The image codec can reduce the frame memory to 1/6, and by using a new architecture it can reduce the line buffer to 50% without any image degradation. The simulation results show that it can gain the mean image degradation of 35.27dB in peak signal to noise ratio (PSNR). The image codec is implemented by the Verilog HDL and synthesized by the Synopsys design compiler using 0.13 μ m Samsung Library.

Keywords: LCD, Overdrive, Compression, Adaptive Quantization Coding.

1. Introduction

Nowadays, liquid crystal displays (LCD) have been significantly considered to have many advantages in comparison with Cathode Ray Tube (CRT) displays in respect of resolution, power consumption, size, thickness, and other critical parameters. However, LCD has a drawback of motion-blur in various display units both in industrial and consumer fields as in [1].

One of the causes of motion blur is the hold-type rendering method of LCD together with the motion pursuing function of human visual system (HVS), which was analyzed in [2-3]. This type of motion blur can be reduced by Inserting black data between every two input frames [4], flashing backlight [5], doubling the frame rate [6], and motion compensated inverse filtering [7-8]. Another cause of motion blur is the slow reaction of the liquid crystal (LC) cell to the change in the pixel value as in [9], and slow response was the main cause of LCD motion blur as in [10]. Therefore, a lot of efforts have been put into speeding up the response of LC materials. This can be done by applying better materials, or by improving LC cell design as in [11]. There is also a well known method for the response time improvement based on video processing called overdrive as in [12]. The technique of overdrive reduces motion-blur by enlarging the desired change of the pixel value in order to force the LC material to react faster as in [13]. The illustration of overdrive mechanism in LCD is shown in figure 1.

Since LCD overdrive compensates for a non-linear effect of the LCD panel, it should preferably be placed at the end of the video processing chain, right before the LCD panel as in [10]. The frame memory is used to store the previous frame, and a lookup table is used to generate the overdrive

voltage by comparing the previous frame and the current one as in [14]. A simple block diagram of general overdrive circuit is shown in figure 2.

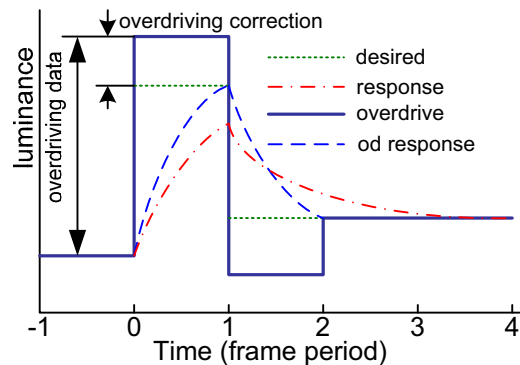

Figure 1 Illustration of overdrive mechanism in LCD.

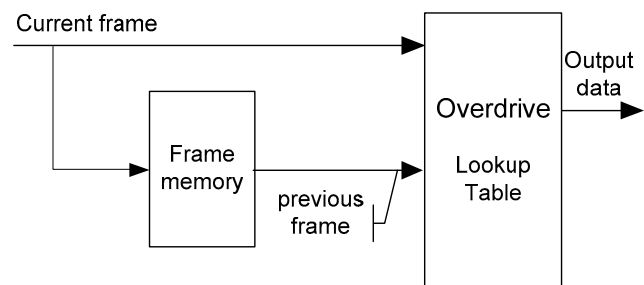

Figure 2 Block diagram of general overdrive circuit.

However, the conventional overdrive technique stores the current frame in the dynamic random access memory (SRAM) which is large and expensive. It is desired to reduce the cost of the system by compressing the data stored in the SRAM as in [15] and [16]. The errors in the decompressed image cause the errors in the amount of overdrive correction and have an effect on the reduction of motion blur. It is necessary to develop an effective compression method to reduce the errors in the decompressed image by the general compressing methods such as quantization, sub-sampling and block truncation coding (BTC). We have developed a novel hybrid image coding (HIC) which was proposed in our previous research including a proposed adaptive quantization coding (AQC) to reduce the errors in decompressed image for the reduction of frame memory to 1/3 as in [17]. To apply the motion blur reduction by doubling the frame rate, there is a demand to double the compression ratio. In this study, we proposed high compression ratio images coding (HCRIC) which can double the compression ratio.

2. Proposed HCRIC

2.1 Architecture of HCRIC

The human visual system (HVS) is less sensitive to color than to luminance (brightness), so that we have proposed an algorithm of HCRIC. First the HCRIC converts RGB color space into YCbCr color space and uses 1/4 down sampling for the chrominance data. Then it uses an efficient coding method of the developed AQC to compress the luminance data which is more sensitive to HVS than color as well as the conventional simple method of BTC to compress the chrominance data. To get more high compression ratio, the min one of the outputs of AQC is compressed by AQC again. The block diagram of the encoder in the HCRIC is shown in figure 3 and that of the decoder in the HCRIC is shown in figure 4.

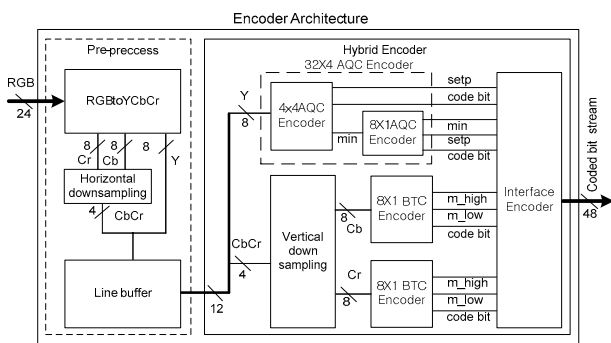

Figure 3 Block diagram of encoder in the HCRIC.

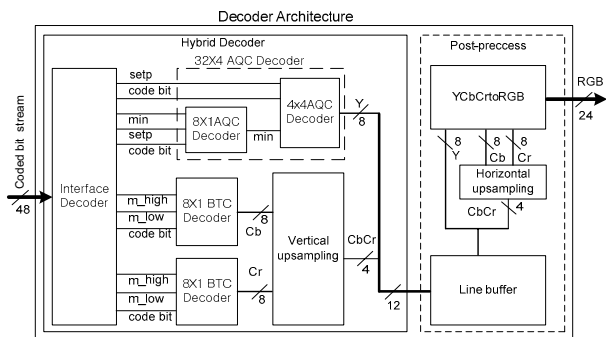

Figure 4 Block diagram of decoder in the HCRIC.

Considering the hardware implementation, we use a new architecture to improve the down sampling module and up sampling module. We separate the down sampling into the horizontal down sampling and vertical down sampling. In this way, the line buffer can be reduced to half without any image degradations. The same way can be used for up sampling module. In hardware implementation, line buffers which use on chip dual port SRAM memory usually occupy 60-70% of chip size. As the codec is to reduce the system cost by reducing the needed frame memory, the line buffers are critical to the codec design.

2.2 Algorithm of the HCRIC

Figure 5 expresses the algorithm of the HCRIC encoder in view of data flow. We transform the input RGB data to

YCbCr in last order, firstly. And then use a line buffer to convert serial data into parallel data for block based compress processing. For sensitive luminance data Y, we select 4x4 AQC to compress them. And to achieve the compression ratio 6, we used 8x1 AQC to compress the min data which is one of the outputs of 4x4 AQC. In case of chrominance data which is less sensitive to the HIV, we use 1/4 down sampling first and then use 8x1 BTC to compress them.

The proposed algorithm is implemented with software in C language and with hardware in the verilog HDL, and it is also synthesized with the synopsys design compiler using 0.13 μ m Samsung Library.

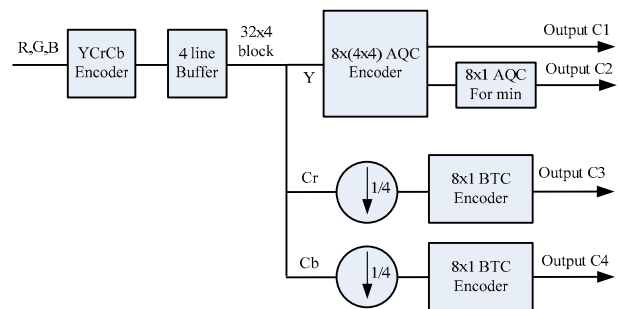

Figure 5 Algorithm of encoder in the HCRIC.

3. Results of Simulation

3.1 Image of Simulation and Evaluation

To evaluate the proposed algorithm of the HCRIC, the following two types of images are used for simulation:

1. General test image.
2. Computer graphic Image.

The simulation has been carried out in three coding methods: the 32x4 HCRIC is the proposed algorithm of HCRIC of 32x4 block; the 16x8 HCRIC is the proposed algorithm of HCRIC of 16x8 block which uses 4x4 AQC for luminance data Y, 4x2 AQC for output min from 4x4 AQC, and 4x2 BTC for chrominance data; the 8x8 BTC uses the BTC of 8 x 8 block to compress the RGB data. The compression ratios are 6.09, 6.09 and 6.4, respectively.

3.2 Evaluation of general test image

The evaluations of general test images have been carried out in the 32x4 HCRIC, the 16x8 HCRIC, and the 8x8 BTC, respectively. The figure 6 shows the simulation result of PSNR, and the figure 7 shows the simulation results of SD of error.

In figure 6, we can see that the PSNR of the 16x8 HCRIC is a little higher than that of the 32x4 HCRIC and the PSNR of the 32x4 HCRIC is much more higher than that of the 8x8 BTC in case of every test image, though the PSNRs of each method are different in these images. The average PSNRs of these images are 36.336dB, 35.596dB and 28.404dB for the 16x8 HCRIC, the 32x4 HCRIC and the 8x8 BTC, respectively. It is said that the 32x4 HCRIC needs only 50% of SRAM line buffer while having a

decrease of 0.740dB in PSNR in comparison with the 16x8 HCRIC. The PSNR of the 32x4 HCRIC can be increased to 7.192dB than that of the 8x8 BTC.

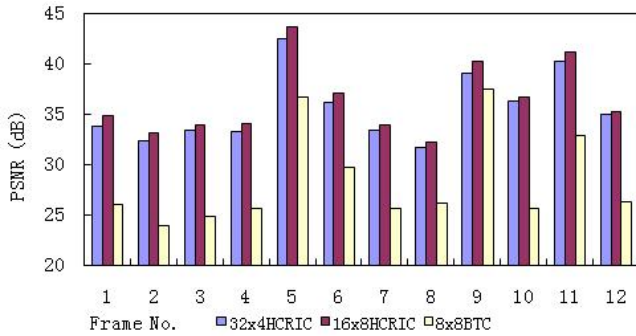

Figure 6 compression ratio of the HCRIC.

Figure 7 indicates that the SD of the 16x8 HCRIC is smaller than that of the 32x4 HCRIC and the SD of the 32x4 HCRIC is much more smaller than that of the 8x8 BTC in case of every test image, though the SD's of each method are different in these images. The average SD's of these images are 4.271, 4.622 and 11.104 for the 16x8 HCRIC, the 32x4 HCRIC and the 8x8 BTC, respectively. It is said that the 32x4 HCRIC needs only 50% of SRAM line buffer while having an increase of 8.2% in SD in comparison with the 16x8 HCRIC. The SD of the 32x4 HCRIC can be reduced to 58.4% than that of the 8x8 BTC.

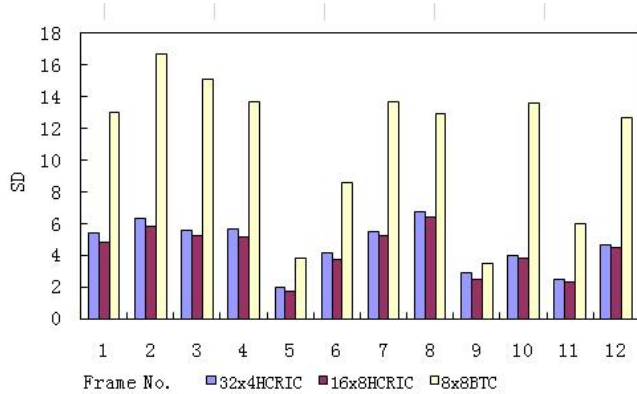

Figure 7 compression ratio of the HCRIC.

3.3 Evaluation of geometrical pattern image

The evaluation of computer graphic test images has been carried out in the 32x4 HCRIC, the 16x8 HCRIC, and the 8x8 BTC, respectively. The figure 8 shows the simulation results of PSNR, and the figure 9 shows the simulation results of SD of error.

In figure 8, we can see that the PSNR of the 16x8 HCRIC is a little higher than that of the 32x4 HCRIC and the PSNR of the 32x4 HCRIC is much more higher than that of the 8x8 BTC in case of every test image, though the PSNRs of each method are different in these images. The average PSNRs of these images are 35.475dB, 34.777dB and 27.177dB for the 16x8 HCRIC, the 32x4 HCRIC and the 8x8 BTC, respectively. It is said that the 32x4 HCRIC

needs only 50% of SRAM line buffer while having a decrease of 0.698dB in PSNR in comparison with the 16x8 HCRIC. The PSNR of the 32x4 HCRIC can be increased 7.599dB than that of the 8x8 BTC.

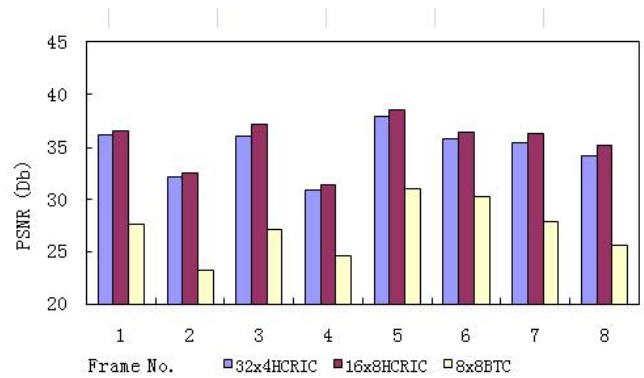

Figure 8 compression ratio of the HCRIC.

Figure 9 indicates that the SD of the 16x8 HCRIC is smaller than that of the 32x4 HCRIC and the SD of the 32x4 HCRIC is much more smaller than that of the 8x8 BTC in case of every test image, though the SD's of each method are different in these images. The average SD's of these images are 4.566, 4.935 and 11.927 for the 16x8 HCRIC, the 32x4 HCRIC and the 8x8 BTC, respectively. It is said that the 32x4 HCRIC needs only 50% of SRAM line buffer while having an increase of 8.1% in SD in comparison with the 16x8 HCRIC. The SD of the 32x4 HCRIC can be reduced to 58.6% than that of the 8x8 BTC.

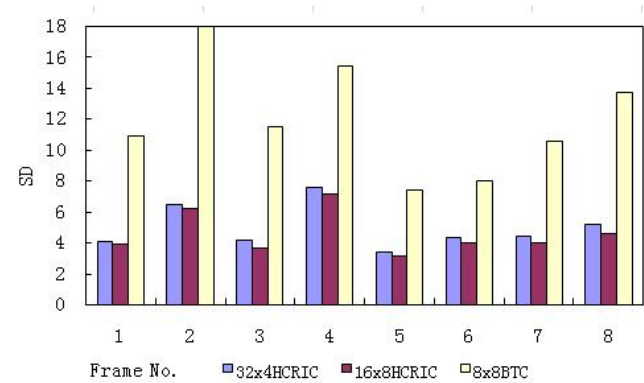

Figure 9 compression ratio of the HCRIC.

Table II Compare the image coding methods and block sizes.

Block size	PSNR(dB)	SD	Line buffer (K)	Frame memory (M)
No compression	xx	0.0	0	~48
4x2 BTC	30.150	8.133	180	~16
4x2 HIC	40.084	2.581	180	~16
8x8 BTC	27.913	11.433	720	~8
16x8 AHIC	35.991	4.389	720	~8
32x4 AHIC	35.268	4.747	360	~8

Table II shows the comparison of the image coding methods and block sizes. In total, the 32x4 HCRIC needs

only 50% of SRAM line buffer while having a decrease of 0.740dB in PSNR and an increase of 8.1% in SD in comparison with the 16x8 HCRIC. Considering about the hardware implementation cost, 32x4 HCRIC is the best tradeoff option to reduce the system cost.

4. Conclusion

In this paper, we proposed a high compression ratio images coding (HCRIC) for the reduction of the frame memory in LCD overdrive. The HCRIC uses a scheme of color space transform first, and then uses the proposed adaptive quantization coding (AQC) to compress luminance data as well as the BTC to compress chrominance data which is down-sampled. The simulation results of the various test images show that the proposed algorithm HCRIC have gained an average improvement of 7.355dB in PSNR and an average reduction of 58.5% in SD in comparison with the BTC. And the line buffer can be reduced 50% by using new architecture without any image degradation. The proposed algorithm can efficiently reduce the image data stored in the frame memory to 16.6%. It reduced the error in decompressed image significantly and achieved more accurate overdrive data with low complexity. The technique can be used to reduce the cost of frame memory in reduction of motion blur in LCD in TV applications and desktop.

Acknowledgments: This research was sponsored by Seoul R&BD Program and ETRI SoC Industry Promotion Center, Human Resource Development Project for IT-SoC Architect. This research was also supported by the MKE(Ministry of Knowledge Economy), Korea, under the ITRC(Information Technology Research Center) support program supervised by the IITA(Institute of Information Technology Assessment) (IITA-2008-C1090-0801-0019). The IDEC provide research facilities for this study.

References

- [1] J. Someya, N. Okuda, H. Sugiura: "The Suppression of Noise on A Dihtering Image in LCD Overdrive", *IEEE Transactions on Consumer Electronics*, Vol. 52, No. 4, pp. 1325-1332, 2006.
- [2] T. Kurita, A. Saito, I. Yuyama: "Consideration on Perceived MTF of Hold Type Display for Moving Images", *Proc. IDW 98*, pp. 823-826, 1998.
- [3] T. Kurita: "Moving Picture Quality Improvement for Hold-Type AM-LCDs", *SID. 01 DIGEST* 986-989, 2001.
- [4] S. Hong, et al: "Motion Blur Reduction in LCDs", *Proc. Asia Display 2004*.
- [5] N. Fisekovic, T. Nauta, et al: "Improved Motion-picture Quality of AM-LCDs Using Scanning Backlight", *Asia Display/IDW 01*, pp. 1637-1640, 2001.
- [6] K. Sekiya and H. Nakamura: " Eye-trace Integration Effect on the Perception of Moving Pictures and a New Possibility for Reducing Blur on Hold-type Displays", *Proc. SID 02*, pp. 930-933, 2002.
- [7] M. A. Klompenhouwer and L. Jan Velthoven: "Motion Blur Reduction for Liquid Crystal Displays: Motion Compensated Inverse Filtering", *Proc. SPIE-IS&T Electronic Imaging*, SPIE vol. 5308, 2004.
- [8] Shimodaira, Y.: "Invited Paper: Fundamental Phenomena Underlying Artifacts Induced by Image Motion and the Solutions for Decreasing the Artifacts on FPDs", *SID. 03 Digest*, pp. 1034-1037, 2003.
- [9] Hao Pan, Xiao-Fan Feng, and Scott Dalay: "LCD Motion Blur Modeling and Analysis", *IEEE 2005*, pp. 358-361, 2005.
- [10] R. H. M. Wubben, G. J. Hekstra: "LCD Overdrive Frame Memory Reduction using Scalable DCT-based Compression", *SID. 04 DIGEST*, pp. 1348-1351, 2004.
- [11] Michiel A. Klompenhouwer and Leo Jan Velthoven: "LCD Motion Blur Reduction with Motion Compensated Inverse Filtering", *SID. 04 DIGEST*, pp. 1340-1343, 2004.
- [12] H. Okumura: "A new low-image-lag drive method for large size LCTVs", *Journal of the SID. 1(3)*, pp. 335-339, 1993.
- [13] Hartman, R.A. et.al.: "Fast Response Electro-Optic Display Device", United States Patent US5, pp. 495-265.
- [14] R. McCartney: "Advanced LCD Timing Controller IC with Memory Assisted Response Time Compensation", *IEEE Int. Conf. VLSI Des.*, pp. 1009-1013, 2004.
- [15] Jun Someya et.al.: "Reduction of Memory Capacity in Feedforward Driving by Image Compression", *SID. 02 Digest*, pp. 72-75, 2002.
- [16] Jun Someya et al.: "A new LCD Controller for Improvement of Response Time by Compression FFD", *SID. 03 Digest*, pp. 1346-1349, 2003.
- [17] Jun Wang, K.Y. Min, J. W. Chong, "A Hybrid Image Coding in Overdriving for Motion Blur Reduction in LCD", *ICEC 2007, LNCS 4740*, pp. 263 - 270, 2007.