

# A Wideband Antenna with Characteristics for DVB-T

Edson T. C. Santos<sup>1</sup>, Gunnar Bedicks Jr<sup>2</sup>, Cristiano Akamine<sup>3</sup>.

<sup>1,2,3</sup> Department of Electronic Engineering and Digital TV research laboratory of Mackenzie Presbyterian University.

São Paulo-SP, Brazil

E-mail: [etcsantos@mackenzie.br](mailto:etcsantos@mackenzie.br)

E-mail: [gbedicks@ieee.org](mailto:gbedicks@ieee.org)

E-mail: [akamine@mackenzie.br](mailto:akamine@mackenzie.br)

**Abstract-** A wideband monopole antenna in a conical structure with a cylindrical element to promote the UHF band cover and indoor use is presented. Experimental results demonstrated that the proposed antenna can operate at the frequency band from 469MHz to 1387MHz which  $VSWR < 2$ . The bandwidth of the proposed antenna cover the DVB-T, LTE700, GSM850, and GSM900 bands. The project was made to be a lower cost and easy construction. The antenna shows peak gain of 3.3dBi. In addition, simulation radiation patterns of the proposed antenna is presented. The measured results of a fabricated antenna agreed well with the simulation results. The proposed antenna has a simple structure and good performance and is a suitable candidate for digital TV applications.

**Index Terms-** Monopole antenna, wideband, conical Structure, low frequency, indoor use.

## I. INTRODUCTION

The actual evolution of analog television systems to digital television systems, from VHF to UHF bandwidth, establishes new challenges and new proposals of antenna configurations for this new system [1]. A receiving antenna used indoors will suffer interference due to obstacles, multipath effects, and placed near metallic structures, etc. Due to these effects the environment in which they are inserted affects indoor antennas performance. However, their performance is significantly changed, these factors are not known at the moment of project elaboration [2]. Antennas with a monopole planar profile with disc and elliptic shapes were proposed and have obtained bandwidth of around 1:10 in the range close to 1GHz [5]. An implemented disc monopole shape antenna covered the system ISDB-T in the bandwidth around 90 MHz to 770 MHz [6]. Planar monopole antennas are also utilized as radiant elements in ultra-wideband systems (UWB), operating in the range close to 3.3 GHz to 10 GHz [7]. To increase the bandwidth of the monopole structure, studies in the literature take the classical structures in conical shape. The classical structure (biconical) is an example of bandwidth structure [8]. The crucial aspect of increasing the bandwidth can be achieved by adjusting how the antenna structure occupies the space [9]. In this paper, the project of a proposed antenna with

coupled feed for the DVB-T, LTE700, GSM850 and GSM900 bands is presented. The structure of antenna is coupled for DVB-T, LTE700 and GSM 900 bands. The cylindrical element promote resonance with inverted cone to cover GDM850 and GSM900. Therefore, the proposed structure has a wide impedance bandwidth that was achieved by modifying the ground plane for inverted cone.

## II. ANTENNA GEOMETRY

Fig.1 shows the geometry of the proposed antenna which consists of a planar monopole as radiator element, a cylindrical element and an inverted cone.

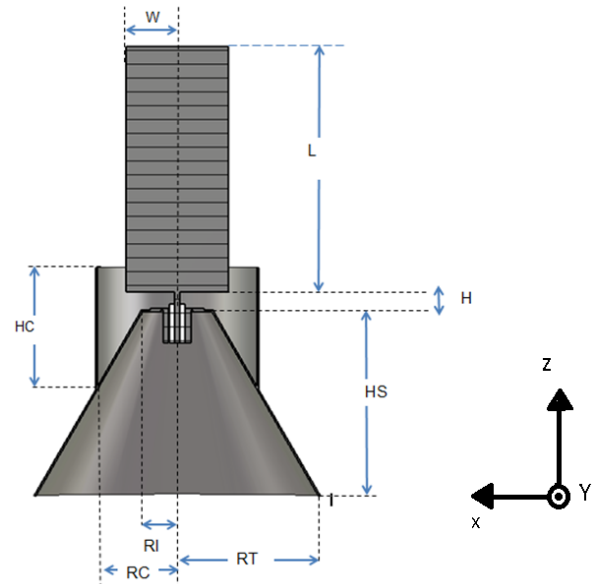

Fig.1. Proposed antenna, with details on the connector profile.

The project began with a monopole antenna (quarter wavelength), composed of a cylindrical radiator element with diameter and height determined to tune with sufficient

bandwidth to receive a UHF signal. Through measurements and simulations, it was observed limitations in bandwidth and reception capacity. This factor was the cause of a search for new configurations allowing cost and simple performance improvements. The structure cross section is presented in Fig.1, with values obtained by simulation, illustrating the planar monopole radiator element, the conical structure and the cylindrical element with the final values obtained by simulations. The radiator element consists in a planar monopole, the  $W$  and  $H$  values were determined and scaled after successive optimizations, that also involved width ( $W$ ), as well as the distance of radiator element to inverted cone ( $H$ ), and the geometry for the respective study band frequency was established. Fig.2 shows a photograph of the fabricated antenna structure in copper (thickness: 0.3 mm).



Fig.2. Photograph of the prototype of proposed antenna.

### III. SIMULATION AND MEASURED RESULTS

This planar monopole is an integral part of a conical structure modified by a cylindrical element in order to promote a bandwidth increase [1]. In the simulation shown in Fig.3, the radiator element in a conical structure shows the HC influence of the cylindrical element for the return loss. Fig.4 shows the influence of the cylindrical element. For HC=0 mm the antenna is a classical inverted cone with a planar monopole as radiator element. When HC=60 mm the optimum value for bandwidth is observed. The final determined parameters of the designed antenna after optimization are summarized in Table 1.

TABLE I

PARAMETERS OF THE PROPOSED ANTENNA [UNIT: MM]

parameters	value	parameters	value
$W$	25	$H$	6
$L$	120	$RI$	18
$HC$	60	$RC$	40
$HS$	90	$RT$	70

The simulation result shows a deviation from the central frequency by the proposed antenna to the DVB-T, LTE700 and GSM 900 bands. The simulated results in the prototype antenna are 453.47 MHz for lower frequency and a bandwidth of 880.33 MHz, reaching the limit of 1333.8 MHz as high frequency: in other words a necessary bandwidth of 98.51%.

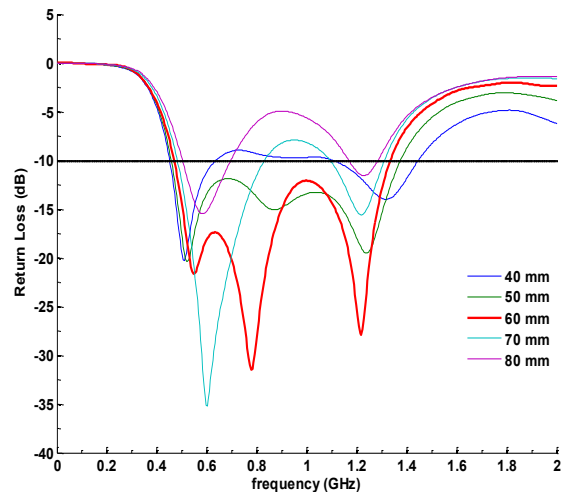

Fig.3. HC simulation influence of cylindrical element in antenna bandwidth.

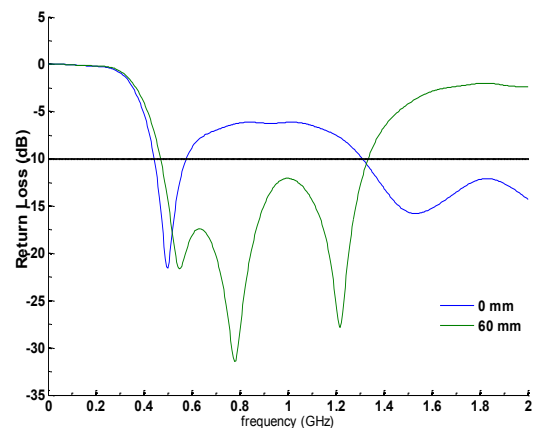

Fig. 4. Effect of simulation HC results: HC=0 mm inverted cone result; HC=60 mm result in triple resonance frequency and bandwidth improvement of the proposed antenna.

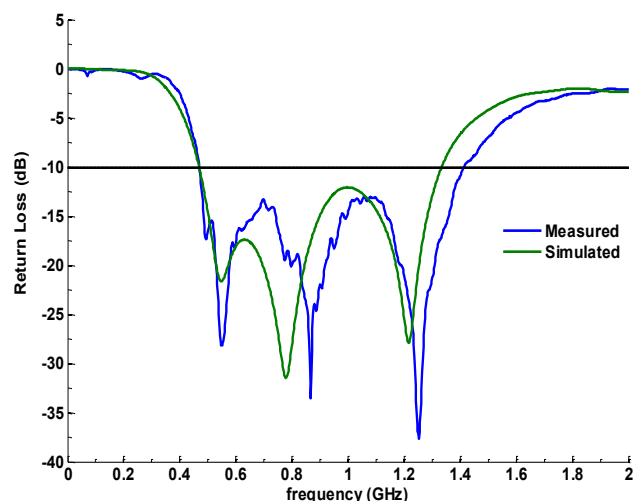

Fig.5. Measured and simulated return loss of the proposed antenna.

Fig. 5 shows the simulated and measured results of return loss of the proposed antenna and has three resonance frequencies:  $f_1=0.548$  GHz,  $f_2=0.776$  GHz and  $f_3=1.217$  GHz. The low band covers DVB-T, LTE700 and the high band over the GSM850, and GSM900. All bands operate properly with

as 10 dB return loss bandwidth, which is an appropriated used value for indoor antennas and mobile phone applications.

Fig. 6 shows the simulated 2D radiation patterns of the proposed antenna at  $f_1=0.548$  GHz,  $f_2= 0.776$  GHz and  $f_3= 1.217$  GHz. Dipole-like radiation patterns with omnidirectional radiation is in the azimuthal plane (x-y plane), the radiation patterns are stable in both low and high frequency as observed. The 3D measured antenna peak gain for the frequencies across the bandwidth is presented in Fig.7. The 3.33 dBi is the maximum value observed. Fig.8 presents the current distributions of the proposed antenna in (a) the RMS value in 0.548 GHz, in (b) the RMS value in 0.776 GHz and in (c) the RMS value in 1.217 GHz.

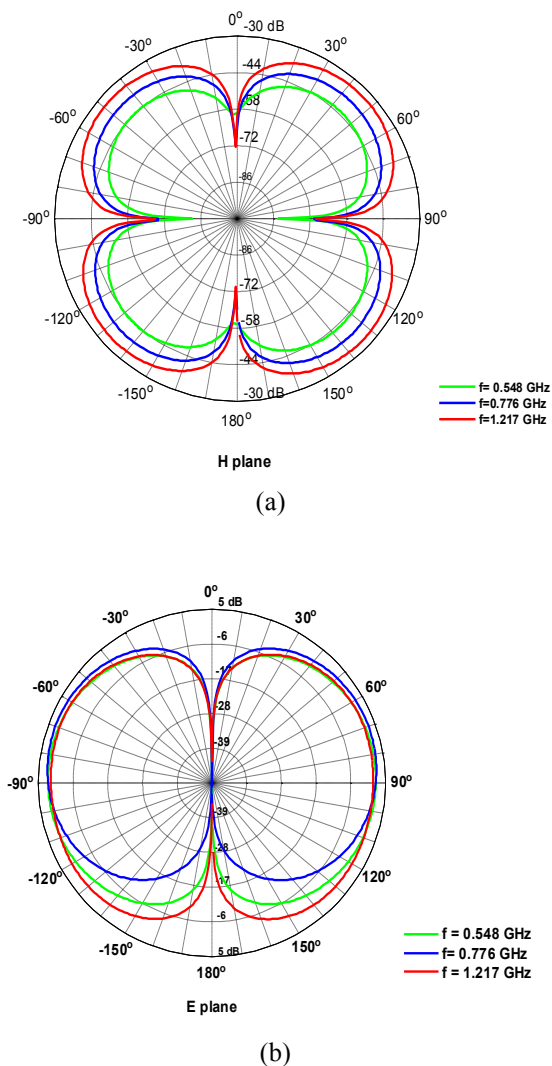

Fig.6. Simulated (a) E-plane, (b) H-plane radiation patterns of the proposed antenna at three resonant frequencies.

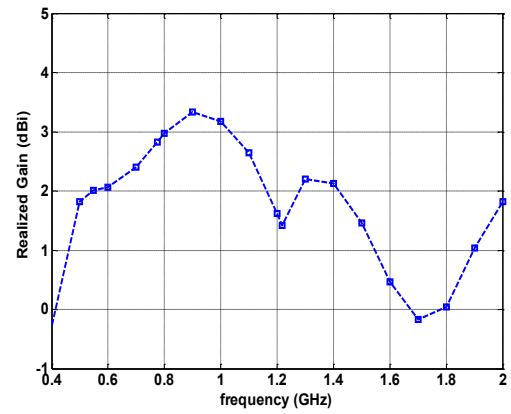

Fig.7. Simulated realized gain of the proposed antenna.

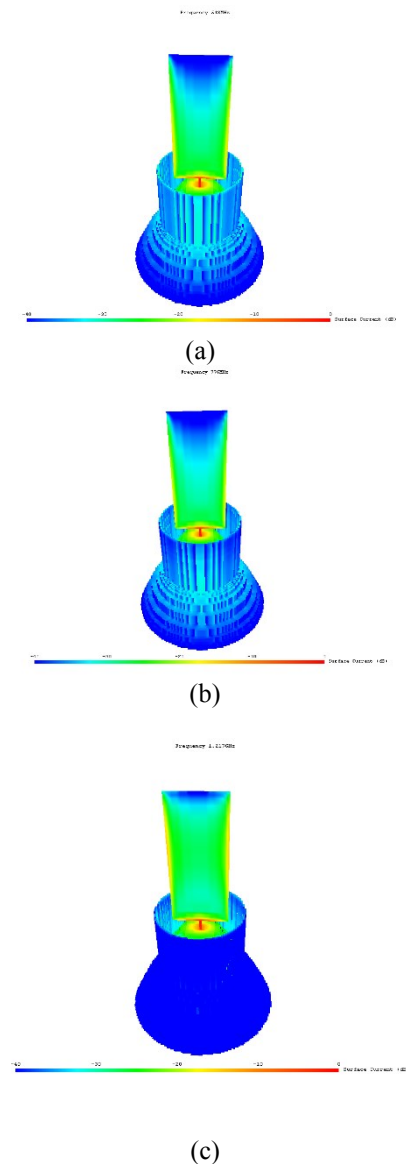

Fig.8. Simulated Surface Current in dB (RMS):

(a) 0.548 GHz (b) 0.776 GHz (c) 1.217 GHz.

## V. CONCLUSIONS

In this work, was described the design, construction and measurements of a new, easy to build antenna, with low cost and simplicity, for indoor use, which uses the technical of cylindrical element in a conical structure with a radiator monopole planar element to increase bandwidth. The inverted cone replaces a finite ground plane, with advantage to promote a reduced dimension of ground plane for radiator element. A prototype was constructed and tested based on simulations in CST Microwave Studio™ as a support tool to analyze the results and necessary adjustments. The prototype showed a bandwidth of 469.6 MHz to 1387.4 MHz, where the value of VSWR smaller than 2 is considered, which corresponds to a bandwidth ratio of 1:2.95. The simulation results indicate that the proposed antenna shows nearly omnidirectional radiation patterns in the far field, which satisfy the requirements for digital TV terrestrial broadcasting systems. The measured results showed that the obtained impedance bandwidth covered DVB-T, LTE700, GSM850, and GSM900 bands.

## ACKNOWLEDGMENT

The authors would like to express their thanks to Mackenzie Presbyterian Institute, which provided all the resources for this research, and the technical team from the digital TV research laboratory of Mackenzie Presbyterian University.

## REFERENCES

- [1] Wei Cheng and Zhongxiang Shen, "Design of a compact and broadband conical monopole antenna," *Antennas and Propagation Society International Symposium, 2009. APSURSI '09. IEEE*, pp. 1-4, 1-5 June 2009.
- [2] W.D. Costa Fernandes and A. de Almeida Prado Pohl, "Analysis of ISDB-Tb signal propagation in indoor environments," *Wireless Communication Systems (ISWCS), 2012 International Symposium on*, pp. 899-903, 2012.
- [3] Yu Yu Kyi, Li Jianying, and Gan Yeow Beng, "Study of Broadband Small Size Conical Antennas," *Antennas and Propagation Society International Symposium 2006, IEEE*, pp. 2025-2028, 2006.
- [4] M. Bender Perotoni and M. Stefanelli, "Planar monopole antennas for the Brazilian Digital TV," *Antennas and Propagation Society International Symposium (APSURSI), 2013 IEEE*, pp. 1212 - 1213, July 2013
- [5] N.P. Agrawall, G. Kumar, and K.P. Ray, "Wide-band planar monopole antennas," *Antennas and Propagation, IEEE Transactions on*, vol. 46, pp. 294-295, 1998.
- [6] M.J. Ammann, "Square Planar Monopole Antenna," *Antennas and Propagation, 1999. IEE National Conference on*, pp. 37-40, 1999.
- [7] M.J. Ammann and Zhi Ning Chen, "Wideband monopole antennas for multi-band wireless systems," *Antennas and Propagation Magazine, IEEE*, vol. 45, no. 2, pp. 146-150, 2003.
- [8] C.A. Balanis, *Antenna Theory- Analysis and Design*, 3rd ed. São Paulo, Brasil: John Wiley & Sons, 2005, vol. 1.
- [9] M. H. C. Dias, J. C. A. Santos, C. A. B. Saunders Filho, "A Novel Broadband Modified Monopole by the Use of a Parasitic Conical Skirt," *Antennas and Wireless Propagation Letters, IEEE*, pp. 1249 - 1252, 2012.
- [10] S. Palud, F. Colombel, M. Himdi, and C. Le Meins, "Reduced-height wideband conical antennas in the VHF/UHF bands," *Antennas and Propagation, 2009. EuCAP 2009. 3rd European Conference on*, pp. 3761-3765, 2009.