

An NIC Voltage Divider for a Linear Transconductor

Fujihiko Matsumoto, Takeshi Sonoda, Toshio Miyazawa,

Shintaro Nakamura, and Yasuaki Noguchi

Department of Applied Physics, National Defense Academy

1-10-20, Hashirimizu, Yokosuka, 239-8686, Japan

TEL:+81-46-841-3810 ext.3624 FAX:+81-46-844-5912 (Dept. of Applied Physics)

E-mail :matsugen@nda.ac.jp (F. Matsumoto)

Abstract: A local feedback linear transconductor requires a voltage divider. For realization of a gyrator-C filter, an output terminal of a transconductor in the filter is connected to an input terminal of itself or another transconductor owing to local feedback of gyrators and equivalent resistors. If NIC circuits are employed in a gyrator-C filter, the voltage divider and the NIC are connected in parallel. This paper proposes a NIC divider that has two roles: one is a voltage divider and the other is an NIC for improvement of the output resistance of a transconductor.

1. Introduction

Active filters are suitable for realization of integrated circuits. An active filter is composed of transconductors, which are voltage to current signal converters. The transconductors are desired to have linear transfer characteristics. A transconductor shown in Figure 1. is known as a linear transconductor, which has local feedback loop[1][2]. Because the transconductor has an intermediate voltage terminal, a voltage divider is necessary for its operation. A gyrator-C filter is one of realization circuits for active filters composed of transconductors. Low output resistances of the transconductors deteriorate the characteristics of gyrator-C filters, such as the passband gain and the passband ripple. It is well-known that a negative impedance converter (NIC)[3] is effective to realize high output resistance. If the NICs are employed in a gyrator-C filter, the voltage divider and the NIC are connected in parallel. This paper proposes a NIC voltage divider, which is a voltage divider composed of two NICs. Using the NIC voltage divider, the number of components and power dissipation is reduced.

2. Local Feedback Linear Transconductor

Figure 1 shows the local feedback linear transconductor. M1 and M3 compose the source coupled pair. M2 and M4 compose the local feedback circuit.

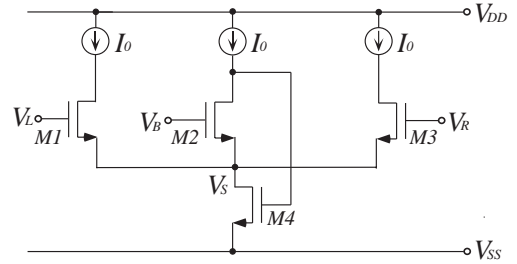

Figure 1. Local feedback linear transconductor

2.1 Transconductance characteristic

In Figure 1., drain current $I_{D1}-I_{D3}$ of M1–M3 are expressed as

$$\begin{cases} I_{D1} = I_L = K(V_L - V_S - V_T)^2 \\ I_{D2} = I_R = K(V_R - V_S - V_T)^2 \\ I_{D3} = I_0 = K(V_B - V_S - V_T)^2 \end{cases} \quad (1)$$

If V_B is the constant voltage, the common mode gain is high. Therefore, to decrease the common mode gain, a voltage divider is applied. Using voltage divider, V_B is expressed as

$$V_B = \frac{1}{2}(V_L + V_R). \quad (2)$$

In this paper, assuming fully differential input voltages, V_L and V_R are expressed as

$$\begin{cases} V_L = \frac{1}{2}V_{in} \\ V_R = -\frac{1}{2}V_{in} \end{cases} \quad (3)$$

From Eq.(1)–(3), I_{out} is expressed as

$$I_{out} = 2\sqrt{I_0 K}V_{in}. \quad (4)$$

From Eq.(4), transconductance G_m is expressed as

$$G_m = \frac{dI_{out}}{dV_{in}} = 2\sqrt{I_0 K}. \quad (5)$$

Eq.(5) shows that the transfer characteristic of this transconductor is linear.

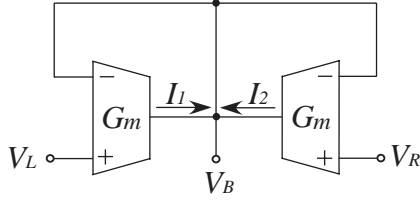

Figure 2. Voltage divider using transconductor

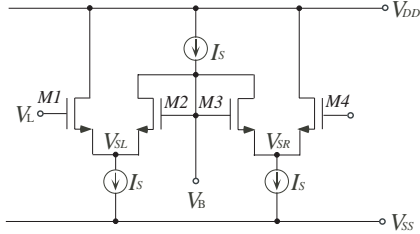

Figure 3. Voltage divider using source coupled pairs

2.2 Voltage divider using transconductor

A local feedback linear transconductor requires a voltage divider that realizes Eq.(2). The simplest voltage divider is a series connection of two resistors which have the same resistance. However, using the voltage divider, input impedance of the transconductor is fixed to the resistance. Therefore, to realize high input impedance of the transconductor, large chip area is required. For implementation on IC, it is valid to use an active voltage divider, which is composed of two transconductors, which is shown in Figure 2. In Figure 2, the output current I_1 and I_2 of the transconductors are expressed as

$$\begin{cases} I_1 = G_m(V_L - V_B) \\ I_2 = G_m(V_R - V_B) \\ I_1 + I_2 = 0. \end{cases} \quad (6)$$

Solving Eq.(6), V_B is expressed as

$$V_B = \frac{V_L + V_R}{2}. \quad (7)$$

Figure 3 shows a circuit configuration of the active voltage divider using two source coupled pairs.

2.3 Input and output impedance

The output nodes of the transconductor shown in Figure 1. are drain nodes of MOSFETs. Therefore, the output impedances of the transconductor is much lower than the input impedance. The input and output impedances are illustrated in Figure 4. From Figure 4, the output impedance is lower than the input impedance in the range lower than 1 MHz. It is expected that the

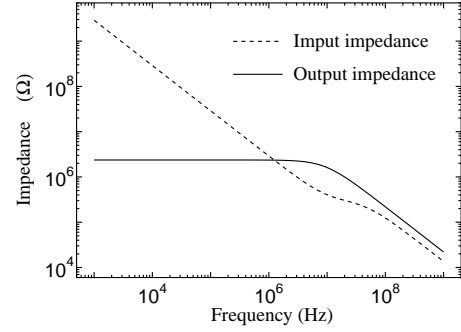

Figure 4. Input and output impedances

characteristic of an active filter using the transconductors is improved by making the output impedance of the transconductor high. A method to realize the high output impedance is connecting an NIC circuit to the output terminals of a transconductor.

3. Using NIC to Improve Output Impedance

3.1 NIC

The impedance of an NIC is expressed as

$$Z_{NIC} = -\frac{V_{NIC}}{I_{NIC}}. \quad (8)$$

The simplest circuit configuration of the NIC is shown in Figure 5 (a). The current I_1 and I_2 in Figure 5 (a) are expressed as

$$\begin{cases} I_1 = G_m(V_2 - V_1) \\ I_2 = -G_m(V_2 - V_1). \end{cases} \quad (9)$$

From Eq.(9), I_{out} is expressed as

$$I_1 = -I_2 = -g_m(V_2 - V_1). \quad (10)$$

From Eq.(10), Z_{NIC} is expressed as

$$Z_{NIC} = \frac{V_2 - V_1}{I_1} = -\frac{1}{g_m}. \quad (11)$$

Figure 5 (b) shows a circuit configuration of NIC using nMOSFETs.

3.2 Improvement of output impedance of transconductor

Figure 6 shows a schematic diagram of connection an NIC and the output terminals of the transconductor, where Z_{ota} indicates the equivalent output impedance of the transconductor, and D indicates a voltage divider for

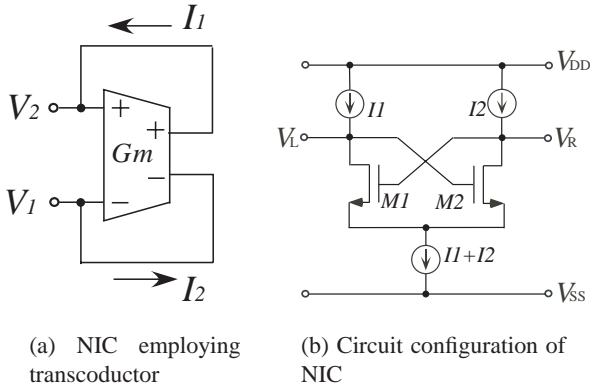

Figure 5. NIC

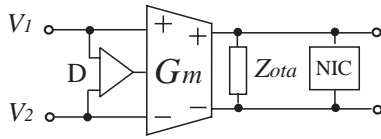

Figure 6. Connecting NIC to transconductor

the local feedback transconductor. The combined conductance G_{out} of the NIC and the transconductor is expressed as

$$G_{out} = G_{NIC} + G_{ota} \quad (12)$$

where G_{NIC} and G_{ota} are the conductance of the NIC and the conductance of the transconductor, respectively. In Eq.(12), if

$$G_{NIC} = -G_{ota}, \quad (13)$$

the combined conductance G_{out} becomes 0. Thus, using the NIC improves the output impedance of the transconductor.

4. NIC voltage divider

For integration of a filter, it is valid to use an equivalent resistors and equivalent inductors which are composed of transconductors. Figure 7 shows an equivalent inductor, in which transconductors G_{m1} and G_{m2} form a gyrator, and Z_{L1} and Z_{L2} are the output impedances of transconductors G_{m1} and G_{m2} , respectively. Watching the surrounding components of the transconductors shown in Figure 7 carefully, it is found that D1 and D2 are connected in parallel with Z_2 and Z_1 , respectively. Therefore, this paper proposes a new circuit that is an NIC voltage divider, which functions as both of an NIC and an voltage divider. Using the NIC voltage divider, the output impedances of the transconductors are increased, and the number of components and power dissipation are reduced. Figure 8 shows the NIC voltage

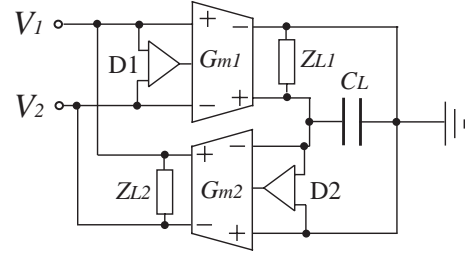

Figure 7. Equivalent inductors

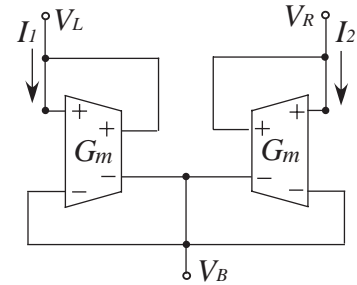

Figure 8. NIC voltage divider

divider composed of two NICs. Figure 9 shows the circuit configuration of the NIC voltage divider realized by using nMOSFETs. From Eq.(3), the output current I_1 and I_2 in Figure 8 are expressed as

$$\begin{cases} I_1 = G_m(V_L - V_B) = G_m\left(\frac{V_{in}}{2} - V_B\right) \\ I_2 = G_m(V_R - V_B) = -G_m\left(-\frac{V_{in}}{2} - V_B\right). \end{cases} \quad (14)$$

Solving Eq.(14), V_B is expressed as

$$V_B = \frac{V_L + V_R}{2}. \quad (15)$$

This shows that the proposed circuit functions as the voltage divider. From Eq.(14), I_1 and I_2 are expressed as

$$I_1 = -I_2 = -\frac{G_m}{2} V_{in}. \quad (16)$$

From Eq.(16), the impedance Z_{ND} seen from the nodes of V_L and V_R of the proposed circuit is expressed as

$$Z_{ND} = \frac{V_{in}}{I_1} = -\frac{2}{G_m}. \quad (17)$$

From Eq.(15) and (17), NIC voltage divider has two roles of a voltage divider and a negative impedance.

5. Filter Design

The proposed technique is applied to an active low-pass filter designed employing the local feedback linear transconductors. Figure 10 shows the prototype elliptic LC ladder lowpass filter. Figure 11 shows the

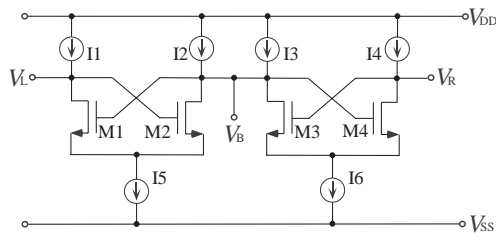

Figure 9. Circuit configuration of NIC voltage divider

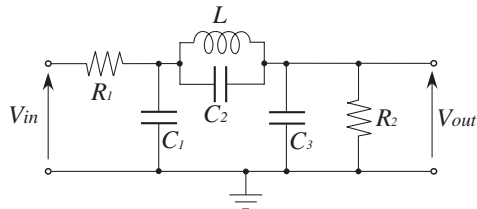

Figure 10. Prototype elliptic LC ladder lowpass filter

gyrator-C elliptic lowpass filter based on the prototype filter shown in Figure 10. The values of C_1 , C_{L2} , C_3 , and C_2 are set at 61.8pF, 49.4pF, 61.8pF, and 10.3pF, respectively. Then, a third-order elliptic lowpass characteristic of 0.28dB passband ripple and 28dB attenuation is realized.

6. Simulation

In order to confirm the validity of the proposed technique, SPICE simulation was carried out. CMOS model used in simulation is BSIM3v3 model of 0.18 μ m process rule. The design conditions are that the supply voltage is $\pm 0.9V$ and I_0 in the transconductor is 10 μ A, which determines the cutoff frequency as 100kHz.

Figure 12 illustrates frequency characteristics of the filters. 'Conventional' means that the conventional active dividers are employed for each transconductor. '4 NIC' means that all voltage dividers are replaced with the proposed NIC dividers. '2 NIC' means that only the transconductors G_{m2} and G_{m3} have the NIC divider. '1 NIC' means that only G_{m2} has the NIC divider. The figure shows that the passband gain becomes higher approaching the ideal value as the NIC dividers are used. Also it should be noted that the passband ripple is improved. The reason why the peak value of the ripple becomes higher in excess is that the phase of the transconductor is delayed around the cutoff frequency.

7. Conclusion

A linear transconductor with local feedback requires a voltage divider. For realization of a gyrator-C filter, an

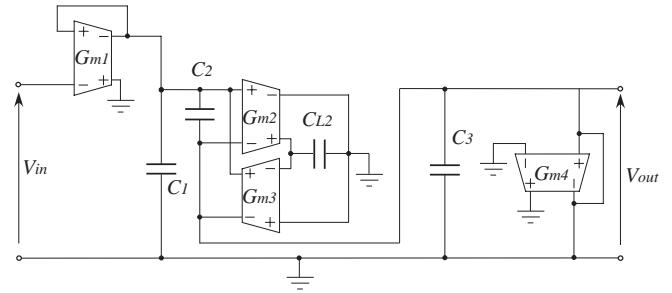

Figure 11. Gyrator-C elliptic lowpass filter

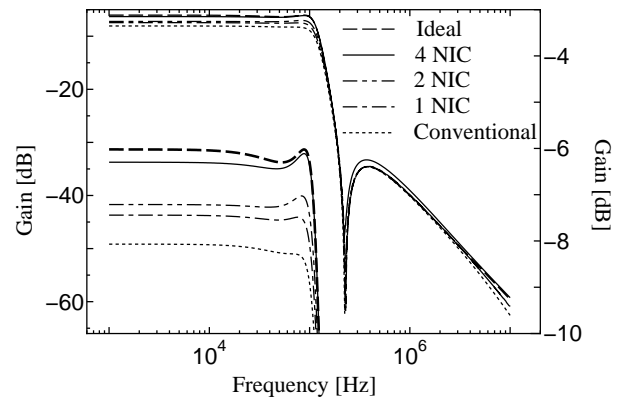

Figure 12. Frequency characteristics

output terminal of a transconductor in the filter is connected to an input terminal of itself or another transconductor owing to local feedback of gyrators and equivalent resistors. If NIC circuits are employed in a gyrator-C filter, the voltage divider and the NIC are connected in parallel. This paper proposes a NIC divider that has two roles: one is a voltage divider and the other is an NIC for improvement of the output resistance of a transconductor. SPICE simulation for a gyrator-C elliptic filter shows that the passband gain is improved by using the NIC divider.

References

- [1] S.R. Zarabadi and M. Ismail, "Linear Voltage to Current Converter Including Feedback Network," US Patent, 5,317,279, 1994.
- [2] T. Miyazawa, et al., "Linear Transconductors Based on a Current-Controlled MOS Transconductor," Proceedings of the ITC-CSCC 2007, III, pp.161–162, July 2007.
- [3] S. Galal and B. Razavi, "10-Gb/s limiting amplifier and laser/modulator driver in 0.18- μ m CMOS technology," IEEE J. Solid-State Circuits, vol.38, no.12, pp.2138–2146, Dec. 2003.