

An Application of Channel Shortening to Multiuser Communications

Hiroaki WATAHIKI¹ and Teruyuki MIYAJIMA²

¹Graduate School of Science and Engineering, Ibaraki University

4-12-1 Nakanarusawa, Hitachi, Ibaraki 316-8511, Japan

²Faculty of Engineering, Ibaraki University

4-12-1 Nakanarusawa, Hitachi, Ibaraki 316-8511, Japan

E-mail : ¹07nm938h@hcs.ibaraki.ac.jp, ²miyajima@mx.ibaraki.ac.jp

Abstract: In block transmission systems such as orthogonal frequency division multiplexing (OFDM), when there are multipaths with delays exceeding cyclic prefix (CP) length, performance degrades due to inter-block interference (IBI). Channel shortening is a promising technique for reducing the effect of IBI. Most channel shortening methods presented before can be applied only to single-user communications. In this paper, we propose to apply a channel shortening method, which exploits the second order statistics (SOS) of the received signals, to multiuser communications. Computer simulation results are presented to show that the SOS method is superior to a conventional method in asynchronous multiuser communications.

1. Introduction

In recent years, high-speed wireless communication technologies based on block transmission have been studied actively. In block transmission systems, cyclic prefix (CP) is inserted between transmitted blocks to prevent inter-block interference (IBI). However, the insert of a long CP reduces spectral efficiency. When there are multipaths with delays exceeding CP length, residual IBI severely degrades the system performance.

To overcome this disadvantage, there are several approaches. Examples include interference cancelation[1], and an adaptive array antenna[2]. We focus on channel shortening methods[3]. Channel shortening methods try to shorten the impulse response of the effective channel, which is a convolution of a physical channel and linear equalizer referred to as time-domain equalizer (TEQ), to within the CP length.

There have been many studies on channel shortening. In most of these studies, however, single-user communication systems are considered[3]. Recently, multiuser communication systems, such as multiuser multiple input multiple output (MU-MIMO) and orthogonal frequency division multiple access (OFDMA), are attracting attention. They can use limited frequency resources effectively and offer high transmission rate. To the best of our knowledge, there is only a channel shortening method[4] that can be applied to multiuser communications. In [4], all the users are assumed to be synchronized, i.e., downlink. When the transmission timing of each user differs from each other, i.e., uplink, this method cannot be applied.

In this paper, we consider the application of a chan-

nel shortening method [5], which is originally developed for single-user communications, to asynchronous (uplink) multiuser communications. The method exploits only the second-order statistics (SOS) of the received signal and does not need the training sequences which waste bandwidth. The most remarkable feature of this method is that it does not need symbol synchronization. This motivates us to apply the SOS method to asynchronous multiuser communications. We evaluate the performance of the SOS method in asynchronous multiuser communication systems by computer simulation.

2. Problem formulation

2.1 Communication model

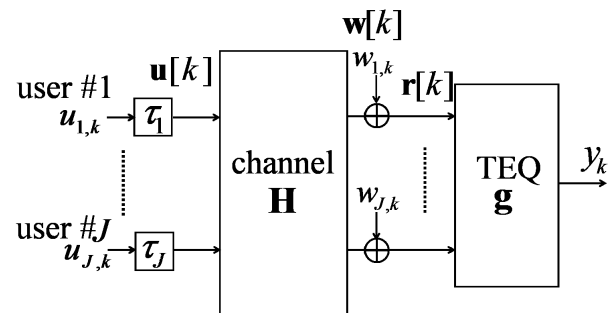

Figure 1. Multiuser communication system using time-domain equalizer.

Figure 1 shows a multiuser system using a TEQ where there are J users. The j th user transmits an OFDM signal $u_{j,k}$ at arbitrary timing τ_j . A transmitted signal $u_{j,k}$ is obtained by applying the inverse fast Fourier transform (IFFT) to a data block and inserting CP of length P between the resulting blocks. The transmitted signals are assumed to be uncorrelated with each other. Assume that each user uses all subcarriers. A physical channel from a transmitter to a receive antenna can be modeled as an FIR filter whose impulse response length is $M + 1$. The received signal at S antennae can be written as

$$\mathbf{r}_k = [r_{1,k} \cdots r_{S,k}]^T = \sum_{j=1}^J \tilde{\mathbf{r}}_{k,j} + \mathbf{w}_k \quad (1)$$

where $(\cdot)^T$ represents the transpose of a matrix. The input to a TEQ of length L can be described in a matrix

form as

$$\mathbf{r}[k] = \begin{bmatrix} \mathbf{r}_k \\ \vdots \\ \mathbf{r}_{k-L+1} \end{bmatrix} = \mathbf{H}\mathbf{u}[k] + \mathbf{w}[k] \quad (2)$$

where $\mathbf{u}[k] = [u_{1,k-\tau_1} \cdots u_{J,k-\tau_J} \cdots u_{1,k-(L+M)-\tau_1+1} \cdots u_{J,k-(L+M)-\tau_J+1}]$, $\mathbf{w}[k]$ is a noise vector, and $\mathbf{H} \in \mathcal{C}^{LS \times (L+M)J}$ can be written as

$$\mathbf{H} = \begin{bmatrix} \mathbf{H}[0] & \cdots & \mathbf{H}[M] & \mathbf{0} & \cdots & \mathbf{0} \\ \mathbf{0} & \ddots & & \ddots & & \vdots \\ \vdots & & \ddots & & \ddots & \vdots \\ \mathbf{0} & \cdots & \mathbf{0} & \mathbf{H}[0] & \cdots & \mathbf{H}[M] \end{bmatrix} \quad (3)$$

$$\mathbf{H}[i] = [\mathbf{h}_1[i] \cdots \mathbf{h}_J[i]], \quad (4)$$

$$\mathbf{h}_j[i] = [h_{j,1}[i] \cdots h_{j,S}[i]]^T. \quad (5)$$

The output of the TEQ is given by

$$y_k = \mathbf{g}^H \mathbf{r}[k] = \mathbf{c}^H \mathbf{u}[k] + \mathbf{g}^H \mathbf{w}[k] \quad (6)$$

where \mathbf{g} is a parameter vector of the TEQ, the effective channels is $\mathbf{c} = \mathbf{H}^H \mathbf{g} \in \mathcal{C}^{(L+M)J \times 1}$, and $(\cdot)^H$ represents the Hermitian transpose of a matrix. The TEQ output can be rewritten as

$$\begin{aligned} y_k &= \sum_j^J \mathbf{g}^H \mathbf{H}_j \mathbf{u}_j[k] + \mathbf{g}^H \mathbf{w}[k] \\ &= \sum_j^J \mathbf{g}_j^H \mathbf{H}_{D,j} \mathbf{u}_{D,j}[k] + \sum_j^J \mathbf{g}_j^H \mathbf{H}_{I,j} \mathbf{u}_{I,j}[k] + \mathbf{g}^H \mathbf{w}[k] \end{aligned}$$

$$\text{where } \mathbf{H}_j = \begin{bmatrix} \mathbf{h}_j[0] & \cdots & \mathbf{h}_j[M] & \mathbf{0} \\ & \ddots & & \ddots \\ \mathbf{0} & \mathbf{h}_j[0] & \cdots & \mathbf{h}_j[M] \end{bmatrix}, \mathbf{u}_j[k] =$$

$[u_{j,k-\tau_j} \cdots u_{j,k-(L+M)+1-\tau_j}]^T$, $\mathbf{H}_{D,j}$ consists of the first P columns of \mathbf{H}_j , $\mathbf{H}_{I,j}$ is its remaining part, $\mathbf{u}_{D,j}[k]$ is the first P element of $\mathbf{u}_j[k]$ and $\mathbf{u}_{I,j}[k]$ is its remaining part. In the above equation, the first term is the desired component and the second term contains the IBI and multiple access interference.

The problem is to find \mathbf{g} such that the impulse response of all effective channels \mathbf{c} , which are composed of physical channels and a TEQ, is shortened.

2.2 FRODO

Forced redundancy with optional data omission (FRODO) is a channel shortening method for multiuser communications [4]. FRODO tries to restore the CP property at the output of TEQ. The cost function to be minimized is

$$J(\mathbf{g}) = E[|y_{P+1} - y_{Q-1}|^2]. \quad (7)$$

In the case of synchronous systems, FRODO can shorten the effective channels, because y_{P+1} and y_{Q-1} contain

the CP part of all users. However, in the asynchronous systems, FRODO may fail to shorten all the channels since they contain the CP part of only synchronized users.

3. Multiuser channel shortening

3.1 SOS approach

In [5], a single-user channel shortening method which exploits the second-order statistics of the received signals was proposed. The SOS method does not need symbol synchronization at the receiver, so that it can be expected to be successfully applied to asynchronous multiuser communications. In this section, we extend the method in [5] to multiuser communications.

Since the transmitted signals are uncorrelated with each other, the correlation matrix of the transmitted signal vector $E[\mathbf{u}[k]\mathbf{u}^H[k+\nu+1]]$ becomes $(\mathbf{J}^T)^{\nu+1}$ where

$$\mathbf{J}^T = \begin{bmatrix} \mathbf{0} & \mathbf{I} & \cdots & \mathbf{0} \\ \mathbf{0} & \ddots & \ddots & \vdots \\ \vdots & \ddots & \ddots & \mathbf{I} \\ \mathbf{0} & \cdots & \cdots & \mathbf{0} \end{bmatrix}, \quad (8)$$

$\nu+1$ is the length which the effective channel impulse response is shortened to. In the absence of the noise, the correlation matrix of the received signal vector becomes

$$\mathbf{R}_{\nu+1} = E[\mathbf{r}[k]\mathbf{r}^H[k+\nu+1]] = \sigma_s^2 \mathbf{H}(\mathbf{J}^T)^{\nu+1} \mathbf{H}^H. \quad (9)$$

If we find the parameter vector of TEQ \mathbf{g} from the null-space of $\mathbf{R}_{\nu+1}$, then we have

$$\mathbf{H}(\mathbf{J}^T)^{\nu+1} \mathbf{H}^H \mathbf{g} = \mathbf{0}, \quad (10)$$

If \mathbf{H} has full column rank, (10) can be rewritten as

$$(\mathbf{J}^T)^{\nu+1} \mathbf{H}^H \mathbf{g} = \mathbf{0} \quad (11)$$

and thus,

$$(\mathbf{J}^T)^{\nu+1} \mathbf{c} = [c_{\nu J+1} \cdots c_{(L+M)J-1} 0 \cdots 0]^T = \mathbf{0}. \quad (12)$$

This implies that the length of each channel impulse response is shortened to within $\nu+1$.

3.2 Algorithm

The algorithm is summarized as follows:

step 1 Obtain the time average estimate of $\mathbf{R}_{\nu+1}$ over B blocks as

$$\hat{\mathbf{R}}_{\nu+1} = \frac{1}{B} \sum_{k=1}^B \mathbf{r}[k]\mathbf{r}^H[k+\nu+1].$$

step 2 Compute the singular value decomposition of $\mathbf{R}_{\nu+1}$ as

$$\hat{\mathbf{R}}_{\nu+1} = \mathbf{Q}_1 \mathbf{\Sigma} \mathbf{Q}_2.$$

step 3 Set the last column of \mathbf{Q}_2 to the parameter vector \mathbf{g} .

4. Simulation results

To evaluate the performance of the SOS method, we carried out computer simulation. Unless otherwise stated, the following parameters are used: the number of blocks $B=1000$, the number of users $J=2$, the size of FFT $N=64$, the CP length $P=4$, the length of window $\nu+1=4$, and the length of channel impulse response $M+1=9$. The received signal-to-noise ratio (SNR) is defined as

$$\text{SNR} = \frac{E[|\tilde{\mathbf{r}}_{k,1}|^2]}{E[|\mathbf{w}_k|^2]} = \frac{\sigma_u^2 \sum_{i=0}^M \|\mathbf{h}_1[i]\|^2}{\sigma_n^2}. \quad (13)$$

Signal-to-interference-and-noise power ratio (SINR) is used as a performance measure. SINR for the j th user defined as

$$\begin{aligned} \text{SINR}_j &= \frac{E[|\mathbf{g}^H \mathbf{H}_{D,j} \mathbf{u}_{D,j}[k]|^2]}{E[|\mathbf{g}^H \mathbf{H}_{I,j} \mathbf{u}_{I,j}[k]|^2] + E[|\mathbf{g}^H \mathbf{w}[k]|^2]} \\ &= \frac{\sigma_s^2 \|\mathbf{c}_{D,j}\|^2}{\sigma_s^2 \|\mathbf{c}_{I,j}\|^2 + \sigma_n^2 \|\mathbf{g}\|^2} \end{aligned} \quad (14)$$

where $\mathbf{c}_{D,j}$ is the first ν elements of $\mathbf{c}_j = \mathbf{H}_j^H \mathbf{g}$ which is effective channel impulse response of j th user, and $\mathbf{c}_{I,j}$ is its remaining part.

The performance of FRODO is also evaluated. In FRODO, the receiver is assumed to be synchronous to the first user.

Figure 2 shows an example of original channel impulse responses and effective channel impulse response obtained by the SOS method and FRODO, when transmission timing of first user and second user is synchronous ($\tau = \tau_2 - \tau_1 = 0$). Both SOS method and FRODO shorten the channel response. Figure 3 shows an example of original channels and effective channel obtained by channel shortening methods in the asynchronous case ($\tau = 4$). Although both methods can shorten the channel of the first user, the effective channel of the second user obtained by FRODO disappears.

Figure 4 compares the SINR performance of the SOS method and FRODO when the difference of transmit timing varies. The SINR of FRODO depends strongly on the timing difference. On the other hand, the SINR of the SOS method remains high irrespective of the timing difference. This result supports the effectiveness of the SOS method in asynchronous multiuser communication systems.

In Figs. 5 and 6, the SINR performances of the second user are shown when SNR varies in the asynchronous case ($\tau = 4$). The SINR of the SOS method improves as SNR increases. On the other hand, the second user's SINR of FRODO is extremely low.

Figure 7 shows the SINR performance as a function of the number of blocks. SINR converges within about 1000 blocks.

Figure 8 shows the SINR for various number of users. The SOS method can be applied to systems with more than two users.

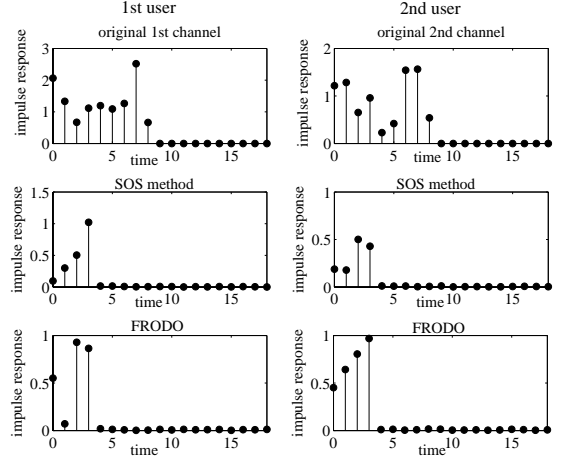

Figure 2. Magnitude of impulse response of original channels and effective channels obtained by SOS method and FRODO in synchronous case ($\tau = 0$).

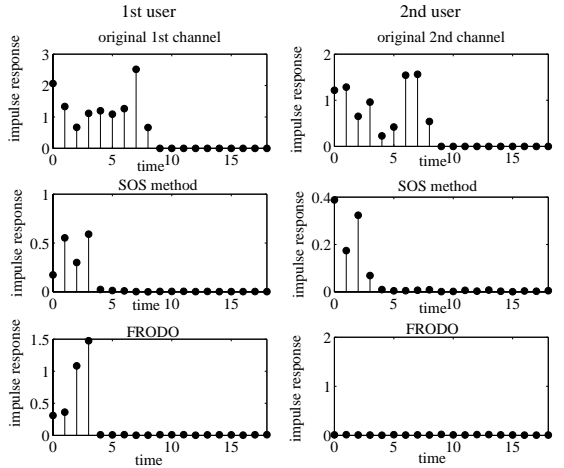

Figure 3. Magnitude of impulse response of original channels and effective channels obtained by SOS method and FRODO in asynchronous case ($\tau = 4$).

5. Conclusion

In this paper, we proposed to extend a channel shortening method proposed in [5] to asynchronous multiuser communications, and showed its effectiveness by computer simulation. It should be noted that the output of TEQ still contains the multiple access interference and thus signal separation is needed to demodulate the data.

Acknowledgment

This research was partially supported by International Communications Foundation(ICF).

References

- [1] D. Kim and G. L. Stuber, "Residual ISI cancellation for OFDM with applications to HDTV broadcasting, IEEE J. Selected Areas in Commun., vol. 16, no. 8, pp. 1590-1599, Oct. 1998.

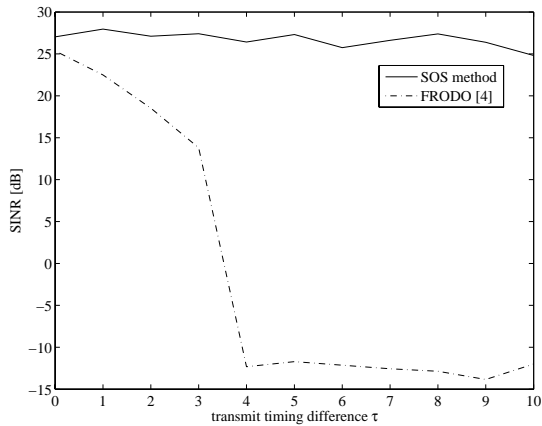

Figure 4. Influence of transmit timing difference.

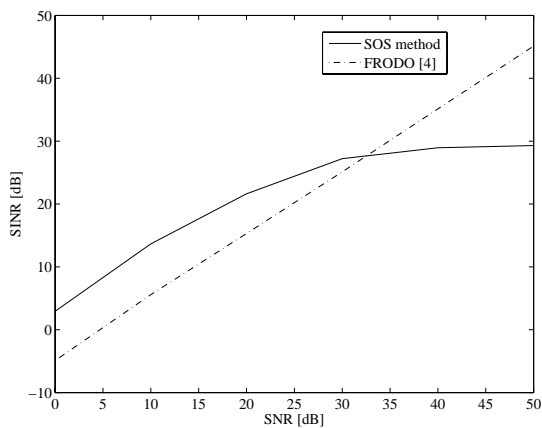

Figure 5. SINR performance for first user.

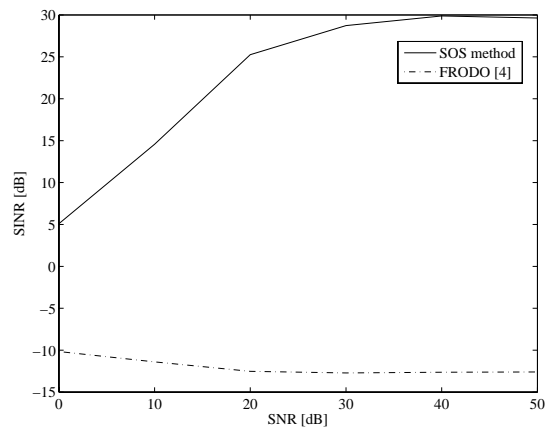

Figure 6. SINR performance for second user.

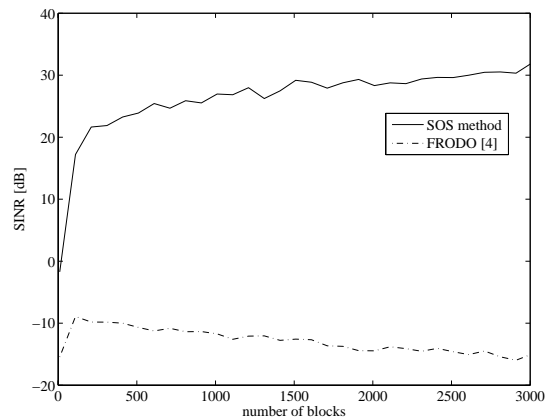

Figure 7. Influence of the number of blocks.

- [2] S. Hori, N. Kikuma, and N. Inagaki, "MMSE adaptive array suppressing only multipath waves with delay times beyond the guard interval for fixed reception in OFDM systems," *Electronics and Communications in Japan, Part 1*, vol. 87, no. 9, pp. 1-8, Sep. 2004.
- [3] R. K. Martin and C. R. Johnson, Jr., "Adaptive equalization: transitioning from single-carrier to multicarrier systems," *IEEE Signal Process. Mag.*, Vol. 22, pp. 108-122, Nov. 2005.
- [4] R. K. Martin, J. M. Walsh, and C. R. Johnson, Jr., "Low-Complexity MIMO Blind, Adaptive Channel Shortening," *IEEE Trans. Signal Process.*, Vol. 53, NO. 4, pp. 1324-1334, Apr. 2005.
- [5] T. Miyajima and Z. Ding, "Second-Order Statistical Approaches to Channel Shortening in Multicarrier Systems," *IEEE Trans. Signal Process.*, Vol. 52, NO. 11, pp. 3253-3264, Nov. 2004.

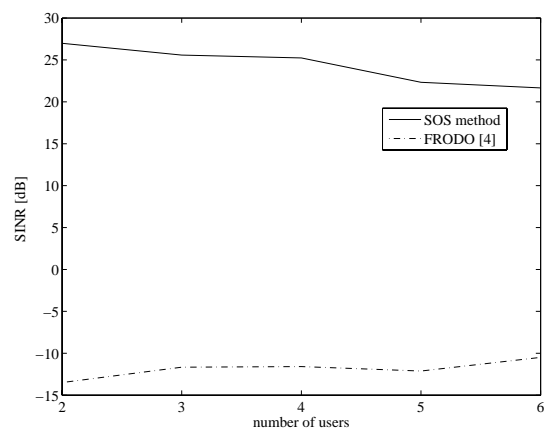

Figure 8. Influence of the number of users.