

Design of a Network Management System for 5G Open RAN

Tse-Han Wang
Network Management Laboratory
Chunghwa Telecom Laboratories
Taoyuan, Taiwan
wangth@cht.com.tw

Yen-Cheng Chen
Department of Information Management
National Chi Nan University
Puli, Nantou 545, Taiwan
ycchen@ncnu.edu.tw

Sin-Jie Huang, Kai-Sheng Hsu,
Chung-Hua Hu
Network Management Laboratory
Chunghwa Telecom Laboratories
Taoyuan, Taiwan
{symb, kshsu, chhu}@cht.com.tw

Abstract—The advent of fifth generation (5G) mobile communication system brings a new vision of the future for a diverse range of vertical industries. Both the number of connected devices and the amount of mobile data traffic will increase significantly. However, the deployment and operation of 5G networks also cost higher than previous generations of mobile networks. Especially, approximately 70% of total network costs are spent in building the radio access network (RAN). Open RAN is potential solution to deploy RANs in a lower cost. An Open RAN can be constructed via components of different vendors. This brings challenges for effective management of an Open RAN. In this paper, we will propose an architectural design of a network management system (NMS) for 5G Open RAN. The proposed NMS is compliant with the O-RAN architecture defined by the O-RAN Alliance. A set of management functions are provided in the NMS to facilitate the operations, administration, and maintenance (OAM) of an Open RAN. The interactions of the Open RAN NMS with current Telecom OSSs are also addressed.

Keywords—5G, Open RAN, Network Management, Operation Supporting System

I. INTRODUCTION

The advent of the fifth generation (5G) mobile communication system brings a new vision of the future for a diversity of vertical industries such as automotive, utilities, manufacturing, healthcare, smart city, and so on. [1] It is anticipated that the number of connected devices as well as the amount of mobile data traffic will be doubled in the near future. The growth in mobile data traffic is contributed by improved capabilities of device, increases in data-intensive content, and more data throughput from mobile networks of subsequent generations [2].

In addition to the increases in data throughput, the 5G networks provide broader coverage and reliable ultra-low latency communications to fulfill the need of all kinds of novel applications. However, the deployment and operation of 5G networks comes with enormous spend in upfront and running costs. Particularly, approximately 70% of total costs in building 5G infrastructure are spent in the deployment of the radio access network (RAN). This leads to a huge financial pressure to telecommunications operators and urges operators to shift and rearchitect their current deployment paradigms. As mobile networks evolve from 4G to 5G, telecommunications operators were compelled to develop a new RAN technology, called Open RAN. Open RAN is an open and disaggregated RAN architecture to achieve more flexibility compared to legacy RANs. Open RAN also introduces intelligence in providing SON (Self-Optimizing Networks) capabilities, and therefore brings the benefits of economics and agility of cloud to the RAN. An Open RAN is built over a vendor-neutral hardware and software-defined technology based on open

interfaces and standards. This will ensure interoperability among devices/units of different vendors [3]. However, as an Open RAN is built with desegregated components, the operations, administration, and maintenance (OAM) of the Open RAN should consider the issues in the decoupling of RAN software from the underlying hardware and the separation of multiple functional units from different vendors. Indeed, the O-RAN Alliance addresses this challenge and defines two interfaces for RAN management. The O1 interface is for managing RAN network elements, and the O2 interface is for managing O-Cloud infrastructure. The openness of these interfaces provides an opportunity for telecommunications operators to develop their own OAM functions and to integrate these functions with their Operation Support Systems (OSS). Thus, it is possible for telecommunications operators to construct a consistent management view of the emerging 5G infrastructures. Furthermore, the emergence of private mobile networks adopting Open RAN technology is another business opportunity for telecommunications operators. Private mobile networks are designed and deployed by enterprises to optimize or enable business processes [4]. Telecom operators can play a part in delivering and managing private mobile networks. This paper will discuss the requirements of an Open RAN in the aspect of network management and then proposes an architectural design of a network management system (NMS) for 5G Open RAN. The relationship of the NMS with other operations management systems will also be discussed.

The remainder of this paper is organized as follows. Section II describes related works. Section III describes the proposed system architecture. Finally, conclusions are given in Section IV.

II. OVERVIEW OF AN OPEN RAN

A. NG-RAN Architecture

A mobile telecommunication system mainly consists of two parts: the Radio Access Network (RAN) and the Core Network (CN). The RAN is composed of a group of base stations, providing radio access and coordinating network resources across wireless devices. A 5G base station is called a next generation Node B (gNodeB, or gNB), and its radio technology is named New Radio (NR), corresponding to Long Term Evolution (LTE) in 4G.

Fig. 1 shows the architecture of the Next Generation RAN (NG-RAN) of 3GPP (3rd Generation Partnership Project). A set of gNBs connected to the 5G Core network (5GC) through the NG interface. These gNBs are interconnected through the Xn interface. Each gNB is comprised of a gNB-CU (Central Unit) and one or more gNB-DU(s) (Distributed Unit). The gNB-CU is connected to each gNB-DU through the F1 interface. Essentially, a gNB-DU is connected to only one

gNB-CU. A gNB-DU may also be connected to multiple gNB-CUs for achieving resilience [5][6].

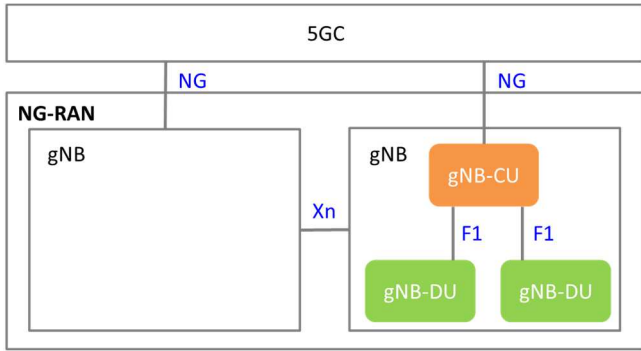

Fig. 1. NG-RAN Architecture

B. O-RAN Architecture

The O-RAN (Open Radio Access Network) Alliance, founded in February 2018, is an industry association for mobile network operators, vendors, and research & academic institutions operating in the RAN industry [7]. The mission of O-RAN Alliance is to define new standards which complements 3GPP (3rd Generation Partnership Project) and ETSI (European Telecommunications Standards Institute) specifications for open and intelligent RAN. The proposed Open RAN aims to promote interoperability on existing 3GPP RAN interfaces via the standardization of RAN elements including a unified interconnection standard for Commercial Off-The-Shelf (COTS) hardware and open source software elements from different vendors.

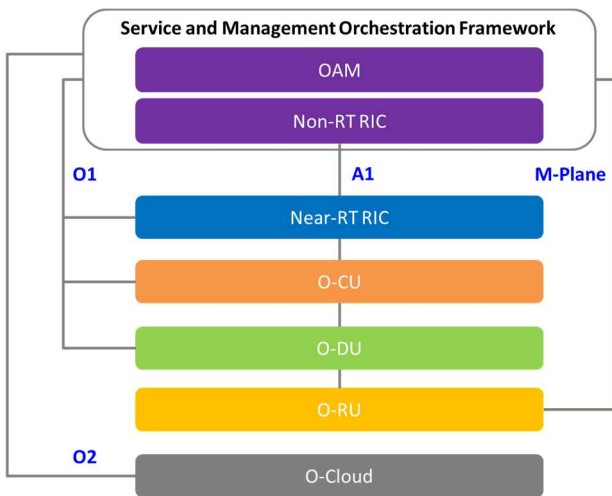

Fig. 2. O-RAN Architecture

A high-level architecture of O-RAN is shown in Fig. 2. The components in the radio side are Near-RT RIC (Near-Real-Time RAN Intelligent Controller), O-CU (O-RAN Central Unit), O-DU (O-RAN Distributed Unit), and O-RU (O-RAN Radio Unit). Located over these components is the Service Management and Orchestration (SMO) Framework, which is a collection of management services for RAN. In addition to the OAM services, the SMO consists of a Non-Real Time RIC function (Non-RT RIC). The main objective of Non-RT RIC is to deliver intelligent optimization for RAN by providing policy-based guidance (called A1 policies) using data analytics and AI/ML (Artificial Intelligence/Machine Learning) training/inference to the near-Real Time RIC

function via the A1 interface [8]. The SMO manages Near-RT RIC, O-CU, and O-DU via the O1 interfaces, and manages O-RU via the Open Fronthaul M-Plane. The M-Plane, same as the O1 interface, provides a variety of O-RU management functions to set parameters on the O-RU side as required by the Control/User and Synchronization Plane (C/U/S-Plane) [9]. The alignment of O1 interface and M-plane is still under discussion in WG10 (Working Group 10) and WG4 (Working Group 4) of O-RAN Alliance.

In the cloudified environment, O-RAN network elements could be implemented in the form of Virtualized Network Functions (VNFs). The cloud infrastructure in which O-RAN network elements reside is called O-Cloud. The O-Cloud provides the SMO with management functions via the O2 interface.

C. O1 Interface

The WG10 of O-RAN Alliance is responsible for defining the O1 interface between managed entities and SMO for FCAPS management. The scope of the O1 interface includes the operation and notification of O1 interface, a set of data and information models for O-RAN. It also specifies the OAM architecture and requirements which are consistent with the overall O-RAN architecture, described in the WG1.

The O1 interface is a management interface between management systems (e.g., NMS) in SMO and O-RAN managed elements (MEs). The OAM functions are summarized in Table I, categorized into eight types of management services including provisioning, fault supervision, performance assurance, trace, file, heartbeat, Physical Network Function (PNF) startup and registration, and PNF software [10].

TABLE I. O-RAN OAM INTERFACE FUNCTIONS AND PROTOCOLS FOR THE O-RAN O1 INTERFACE

#	MnS	Function	Protocol
1	Provisioning	CRUD Managed Objects	NETCONF
		Managed Object Instance Change Notification	HTTPS
		Subscription Control	NETCONF
2	Fault Supervision	Fault Supervision Control (Get Alarm List, Clear Alarm)	NETCONF
		Fault Notification	HTTPS
3	Performance Assurance	Performance Data File Reporting	HTTPS
		Performance Data Streaming	HTTPS
		Measurement Job Control	NETCONF
4	Trace	Subscriber and Equipment Trace	SFTP/FTPES (Trace files) or HTTPS (Streaming)
		Trace Control	NETCONF
5	File	File Ready Notification	HTTPS
		File Download	NETCONF, SFTP/FTPES
		List Available Files	NETCONF
6	Heartbeat	Heartbeat Notification	HTTPS
		Heartbeat Control	NETCONF
7	PNF Startup and Registration	PNF Plug-n-Play	Not specified
		PNF Registration	HTTPS

8	PNF Software	Software Package Naming and Content	Vendor specific
		Software Inventory	NETCONF
		Software Download	NETFONF, SFTP/FTPES, HTTPS
		Software Activation Pre-Check	NETCONF
		Software Activate	NETFONF

III. DESIGN OF AN OPEN RAN NETWORK MANAGEMENT SYSTEM

An Open RAN NMS is an Operations Support System (OSS) designed for managing Open RAN network elements of different vendors via the O1 interface or open APIs of vendor's Element Management System (EMS). The NMS is equipped with operations management functionalities including fault, configuration, performance, and security management of Open RAN networks.

A. Design Concept

Operations, Administration, and Maintenance (OAM) play a crucial role in the telecom operations and will heavily impact 5G applications and services. Reducing CapEx (Capital Expenditure) is the major merit of deploying Open RAN, which transforms a proprietary environment to an interoperable multi-vendor ecosystem. The openness and intelligence of RAN enables faster innovation and better customer service experiences. However, the benefits of Open RAN can only be realized by leveraging the telecom Operations Support System (OSS) to bring automation to the RAN rather than the physical intervention of human beings. To fulfill the operational requirements for Open RAN, this study addresses the requirements of OAM for Open RAN on the basis of Chunghwa Telecom's practical experiences in operations management, the O-RAN OAM architecture, and the O1 interface specification defined by O-RAN Alliance.

B. System Architecture

As shown in Fig. 3, the system architecture of the proposed Open RAN NMS is composed of dashboard, open APIs, and four management components, including operations management, device adaptors, core functions, and southbound plugins.

The dashboard is a web-based Graphical User Interface (GUI), providing a centralized resource-oriented visibility for operators over the multi-vendor Open RAN. The detailed information of each Open RAN equipment, e.g., device configurations, alarms, and performance counters, can be obtained on the dashboard. The open APIs are implemented as RESTful web services, which allow other systems to access data and interact with operations management functions over HTTPS. In fact, most information in the dashboard is obtained through the open APIs.

The Open RAN NMS provides five operations management functions, including fault supervision, performance collection, configuration management, software management, and log management. These functions were designed according to the O1 interface. Table II illustrates the relationship of these operations management functions and the management services (MnS) of O1 interface.

Fault supervision receives alarm and heartbeat notifications to monitor the current status of managed devices. Performance collection periodically gathers performance

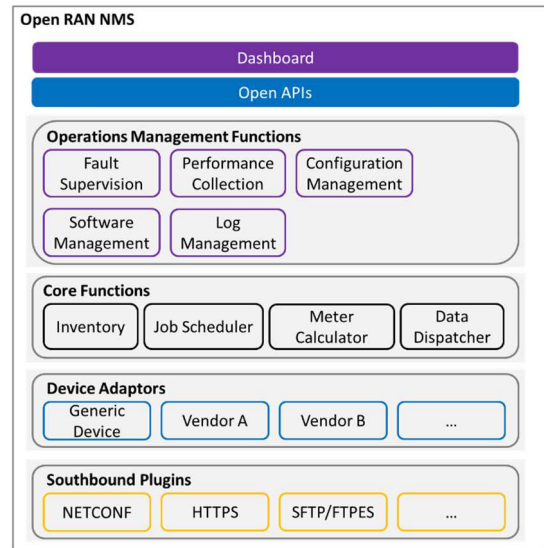

Fig. 3. System Architecture of Open RAN NMS

measurement data from the file repository, or passively receives streaming performance measurement data in a specified interval. The performance metrics with corresponding key performance indicators (KPIs) will be presented in prepared statistics reports for operators. The reports reveal the overall operational status of managed devices. Configuration management displays device configuration information of managed devices, and allows operators to configurate parameters for managed devices. Configuration management also provides a diagnostics function which performs subscriber and equipment trace control on the managed device with trace records in the form of files or streaming data. Software management displays the current software version of managed devices and enables the scheduling of software package upgrades of devices by different upgrade policies. Log management records events emitted from devices. The managers can realize how the device works from the logged events.

TABLE II. THE MAPPING BETWEEN OPERATIONS MANAGEMENT FUNCTIONS OF THE OPEN RAN NMS AND THE MANAGEMENT SERVICE OF O1 INTERFACE

#	Operations Management Functions of Open RAN NMS	MnS of O1 Interface
1	Fault Supervision	Fault Supervision
		Heartbeat
2	Performance Collection	Performance Assurance
3	Configuration Management	Provisioning
		Trace
		PNF Startup and Registration
4	Software Management	PNF Software
5	Log Management	N/A

Core Functions consist of four modules: *Inventory*, *Job Scheduler*, *Meter Calculator*, and *Data Dispatcher*. *Inventory*, as the root service of the NMS, supports all possible OAM models and different deployment options of the managed devices. There are three possible types of management architecture models: flat, hierarchical and hybrid. In the flat management architecture model, all MEs of a managed device directly provide the O1 interface to the SMO. In the hierarchical management architecture model, the O-RU is

managed by the O-DU via the M-Plane interface, and doesn't directly provide management functionalities to the SMO. In the hybrid management architecture model, the O-RU can be managed by both the O-DU via the M-Plane interface and the SMO via the O1 interface. Regarding the deployment options of a managed device, the managed device may contain one or more ME(s). In the case of a single ME, an ME provides O-CU, O-DU and O-RU managed functions. It could also be a two-ME case in that one ME is the Near-RT RIC and the other provides O-CU/O-DU and O-RU managed functions [11]. *Job Scheduler* manages a bunch of scheduled tasks and executes tasks in a regular interval or at a specified date and time. *Meter Calculator* provides mathematical functions for calculating performance counters to acquire KPIs or values in other units. *Data Dispatcher* is used to export collected data to external repositories. An external repository may be an API endpoint of the OAM system or a datastore such as a message queue or a database.

To support multi-vendor Open RAN devices, the Open RAN NMS allows the extension of device plugins to resolve the differences between vendors' implementations. The capability is achieved by the device adaptors via an intermediary abstraction of devices. The device adaptors connect and interact with managed devices by the use of southbound plugins. Southbound plugins provide a set of protocol implementations for communication in a standard fashion. Besides, streaming telemetry collection is also supported in southbound plugins. Streaming telemetry is a push-based mechanism that receives streamed data from devices continuously. For example, the O-RAN ME send asynchronous notifications via JSON-encoded VNF Event Stream (VES) events, which are generalized to support network-function event streaming [12].

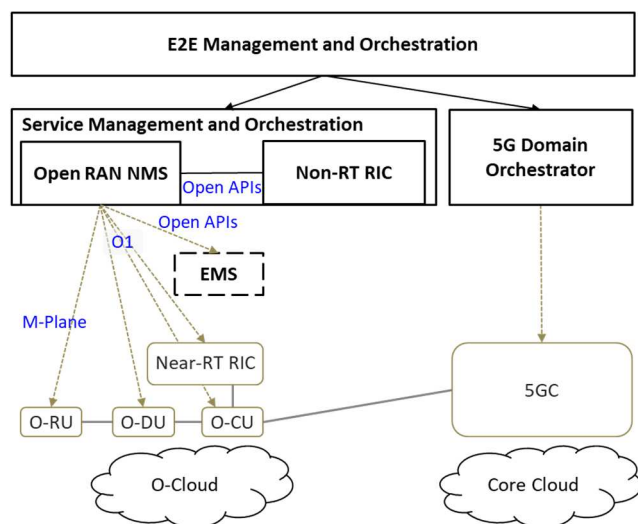

Fig. 4. Relationship with other system entities

C. Relationship with Other System Entities

Most telecom operations are complicated. Thus, telecommunications operators highly rely on OSS and BSS systems to support daily operations of their business. In Chunghwa Telecom, current BSSs/OSSs are implemented on the basis of the New Generation Operations Systems and Software (NGOSS) [13] framework, proposed by the TM Forum. The management scope of BSSs/OSSs covers end-to-end (E2E) service and networks. The SMO defined by O-RAN

Alliance only focuses on the management of RAN. Thus, the SMO is located under the E2E management and Orchestration.

As illustrated in Fig. 4, in the SMO framework, the Open RAN NMS collects data from RAN elements through the O1 interface or open APIs provided by vendors' EMS. These collected data are essential to non-RT RIC for the purpose of data analysis and can also be fetched via open APIs of the Open RAN NMS. AI/ML (Artificial Intelligence/Machine Learning) technologies can be applied in the data analysis to derive data-driven insights to optimize RAN resources. The collected data with data analysis is needed not only for non-RT RIC but also for the management of E2E services and networks to acquire the holistic view of the E2E networks.

IV. CONCLUSION

Moving towards open networking is imperative for telecommunications operators to enable business agility and to create innovative services, which both are realized by leveraging network automation and programmability. Telecommunications operators are increasingly moving away from siloed processes to streamlined and seamless integration across networks and services. An Open RAN NMS is a key building block to provide resource-facing functions for telecom operations in the RAN domain. Moreover, the integration of the Open RAN NMS with other OSSs would facilitate process automation for service and network fulfillment and assurance. Besides, the development of an Open RAN NMS is targeted at the management of both private and public mobile networks. Public mobile networks intend to deploy Open RANs, especially in rural areas.

The proposed design of an Open RAN NMS considers most requirements of operations management in the Open RAN domain. In the future, we will further study the work distribution between the NMS and the cloud management system, the management of virtualized O-RAN elements, e.g., LCM (Lifecycle Management), and the management of the O-Cloud infrastructure to extend the functional capabilities.

REFERENCES

- [1] Cisco, "Cisco Annual Internet Report (2018–2023)," March 2020.
- [2] Ericsson, "Ericsson Mobility Report," November 2020.
- [3] Accenture, "OpenRAN: The next generation of radio access networks,"
- [4] Gabriel Brown, "Private 5G Mobile Networks for Industrial IoT," July 2019.
- [5] ETSI, "3GPP TS 38.401: NG-RAN; Architecture description (3GPP TS 38.401 version 15.4.0 Release 15)," April 2019.
- [6] 5G Americas, "Management Orchestration & Automation," November 2019.
- [7] "O-RAN Alliance," <https://www.o-ran.org>
- [8] O-RAN Alliance, "O-RAN Use Cases and Deployment Scenarios," February 2020.
- [9] Anil Umesh, Tatsuro Yajima, Toru Uchino, Suguru Okuyama, "Overview of O-RAN Fronthaul Specifications," NTT DOCOMO Technical Journal, vol. 21, no. 1, July 2019.
- [10] O-RAN Alliance, "O-RAN Operations and Maintenance Interface Specification v4.0," November 2020.
- [11] O-RAN Alliance, "O-RAN Operations and Maintenance Architecture v4.0," April 2020.
- [12] ONAP, "VES Event Listener 7.2.1," https://docs.onap.org/projects/onap-vnfrqts-requirements/en/latest/Chapter8/ves_7_2/ves_event_listener_7_2.html, January, 2021.
- [13] J. Strassner, J. Fleck, J. Huang, C. Faurer, T. Richardson, "TMF White Paper on NGOSS and MDA," November 2003