

## A Consideration of Spatial Video Coding Schemes for Updatable Video Delivery

Mei KODAMA<sup>1,2</sup>

<sup>1</sup> Graduate School of Integrated Arts and Sciences, Hiroshima University, Japan

<sup>2</sup> Information Media Center, Hiroshima University, Japan

1-7-1-C112 Kagamiyama Higashi-hiroshima, 739-8521, Japan

E-mail: mei@hiroshima-u.ac.jp

**Abstract:** Recently, over the broadband internet, we had often used many video and music contents supported by MPEG-1,2,4, H.261, H.263, H.264/AVC video coding standards. In video coding standards, layer coding methods had been studied by many researchers and for example, SNR scalability, spatial scalability and temporal scalability had been adopted. In addition, we had proposed “the concept of updatable scalable video coding (USVC)”, considering the functionality of video data. It shows the renewal of video quality for video data from the viewpoints of coding distortion and image resolutions and so on. In this study, we focus on data prediction of DCT coefficient domain, the coding efficiency of USVC for the change of quantization accuracy using quantization parameters based on coding controller. Especially, spatial scalable coding types are used. In the theoretical approach, the prediction coding of differential data among layers is proposed newly. By the simulation results, the relation between the coding tendency of some test sequences and quantization parameters in low quality and high quality layers are shown.

It realizes the renewal of video quality. Additionally, it shows data updating for video from the low quality data to high quality data. There are some study issues, for example, the coding efficiency of USVC for SVC and the increment of processing time for the hierarchical coding process to decrease database capacity for a large number of video.

In this study, we firstly explain about our proposed contents delivery method using scalable video data over the network in Fig. 1. Proposed delivery system consists of center server, cache servers, and contents users' terminals. The features are shown as follows. This system uses the scalable bitstream in which it can update from low quality data to high quality data. These data are stored in the center server, and this server manages the scalable bitstreams. The system, which manages simulcast data, has all quality video data, which users require, but proposed method does not need. Comparing with simulcast data management in VoD system, scalable data management is efficient from the concept of data compression. If users want to update to high quality data of which they have already had low quality data, after they have only to get differential bitstream from servers, updating process is worked according to the quality of data they require. In Fig. 1, we show four cases of quality selection in user side. (i) and (ii) show each quality selection, but (iii) shows high quality selection after low quality used, and (iv) is low quality selection after high quality indicates data transmission and the situation of cached data in local disk in each case.

In this paper, we propose the scalable data transmission method using updating transcoder, and evaluate it for simulcast type, which use the quality data individually.

### 1. Introduction

Now many people often enjoy movie, digital TV and video applications in the world wide supported by broadband internet and video coding standard, such as, MPEG-1,2,4, H.261, H.263, H.264/AVC[1]-[5]. Video packages or on-demand service had been used from the late 1990s, especially, not only compression schemes but also functionality request to video technology, and scalable video coding (SVC) had been studied in coding standards. On the other hands, we focused on the functionality of SVC for on-demand services, and we had proposed “the concept of updatable scalable video coding (USVC)”.

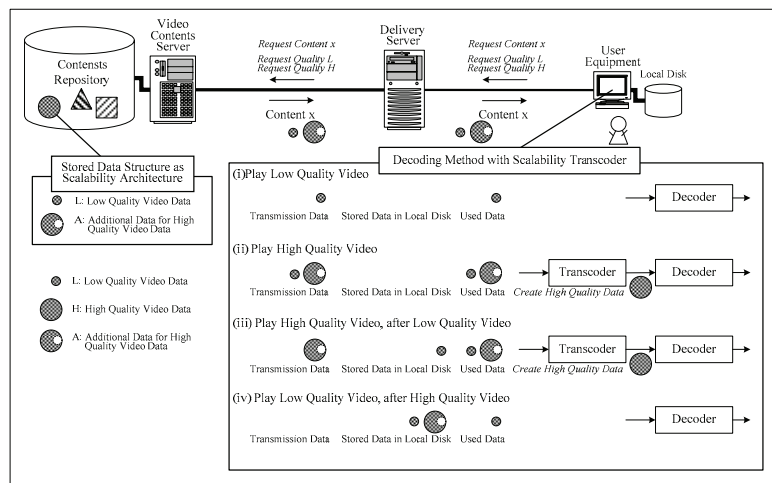

Fig. 1 Video contents delivery method using USVC for multi-quality selection

In this study, in order to evaluate USVC, we pay attention to the influence of the coding efficiency and the quality for quantization, and these results are shown by coding simulation in the case of spatial coding types.

After the coding schemes as spatial coding type are indicated, finally they clarify that proposed schemes are available in USVC.

In the next section, the concept is shown.

## 2. Updatable Scalable Video Coding

We summarize the feature of USVC compared with MPEG-2 bitstream scalability. Overview of proposed updatable bitstream scalability process is shown in Fig.2.

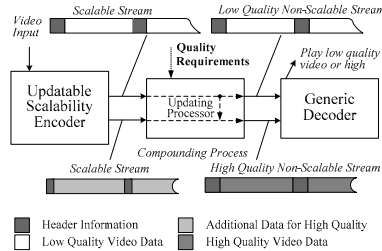

Fig. 2 Process of data updating in USVC

In bitstream scalability, a scalable decoder realizes the function of changing image quality. On the other hand, updatable scalability does not use scalable decoder and it has updatable process outside decoder. That is to say, transforming process works after receiving any video stream. Standard scalability needs scalable decoder, so it is problem of decoding time in generic video delivery services because of scalable decoder. It is the feature that updatable scalability does not need scalable decoder.

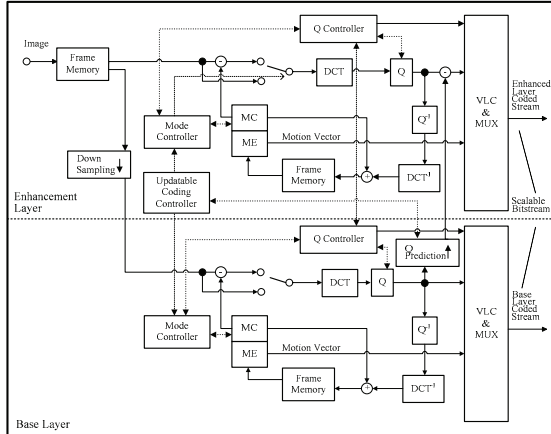

Fig.3 Encoder of USVC based on spatial coding type

There is low quality data by non-scalable video encoder, high quality data is made as differential data between low and high resolution video. When users want to play high quality video, two bitstreams are combined by updatable processor, which works in order to reconstruct in bitstream level. For example, a non-scalable decoder is defined as MPEG-2 MP@ML decoder [6]. But it can't normally realize the function of multi-quality, but the proposed scalability can realize one.

Our proposed encoder of the spatial updatable scalability to update the video quality in size domain is shown in Fig. 3.

MPEG-2 spatial scalability coding uses not only temporal prediction, but also spatial prediction, while updatable coding uses simulcast coding basically, so base layer's stream is MPEG-1 stream and differential data is made by differential coding in DCT coefficients [8]. The feature is that subtraction process works in quantized DCT coefficients between low and

high resolution layers in the enhancement layer. There are some transcoding methods [9]-[14], but they cannot resolve the coding architecture of scalable video data clearly. Consequently, we consider the prediction schemes in Fig.4, and basically upsampling in the same method of spatial scalability (method (i)).

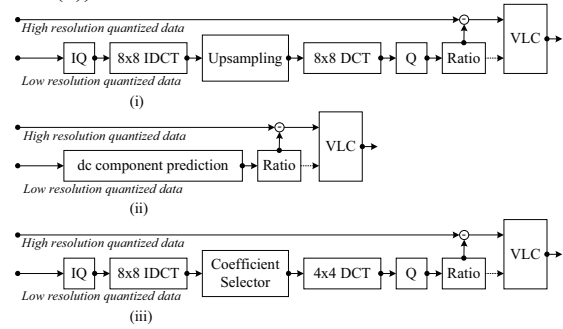

Fig.4 Prediction schemes

Here, the differential data coding scheme using 8x8 IDCT, upsampling and 8x8 DCT in the same domain in high resolution layer. Also we propose dc prediction only (ii), 4x4 DCT prediction (iii) and these adaptive schemes ((ii)/(iii)) without upsampling as the prediction methods. In other words, DCT transcoding schemes are required for spatial coding type.

About the Q prediction, the detail simulation results of coding are shown in the next section. In addition, the coding efficiency of them is evaluated by simulation experiments.

## 3. Simulation Experiments

We focus on the intra coding in USVC, and evaluate the differential data between base and enhancement layers.

As quantization parameters influence the coding efficiency and the quality of moving pictures, they are significant parameters. In this study, we pay attention to the change of the range of quantization and the coding entropy of differential data. At first, the simulation conditions are shown in next section.

### 3.1. Conditions

The condition of coding simulation is shown by Table. 1. Basically, the intra coding based on TM-5 is used, for example, quantization matrix, but MC coding is not dealt with to simplify in the evaluation of coding efficiency.

In this study, firstly PSNR results in test sequences show that the accuracy of DCT coefficients influences the quality of image. By the results, the coding efficiency of USVC is related to prediction schemes and q parameters between low and high layer.

Table.1: Conditions

Test sequence	ballet, bicycle, football
Frame	1 [frame]
Signal	Luminance
Quantization method	MPEG-2 TM5, intra type
Q parameters	QB: base layer QE: enhancement layer
USVC	Spatial coding type (i)(ii)(iii)
Evaluation methods	PSNR, Entropy

### 3.2. Consideration

Here, in USVC as coding efficiency, the entropy of differential data is used to evaluate in spatial schemes. Fig. 6,7,8 show the results of spatial coding type((i),(ii),(iii)) in Fig.4.

However, QB is q parameter in base layer, and QE is q parameter in enhancement one.

By the results, if QB is large, the entropy becomes small. That's because of reduction of video quality. We can know the relationship of q parameters for each coding rate. On the other hand, spatial coding schemes have other issues of correlation of layer's resolution. From Fig.7, the base coding efficiency is indicated, but prediction method (ii) or (iii) are more effective than it in some cases. In this study, down-sampling and up-sampling methods use average processing and simple magnification, but as the correlation of coded data in each layer is lowered, basic approach is not always useful.

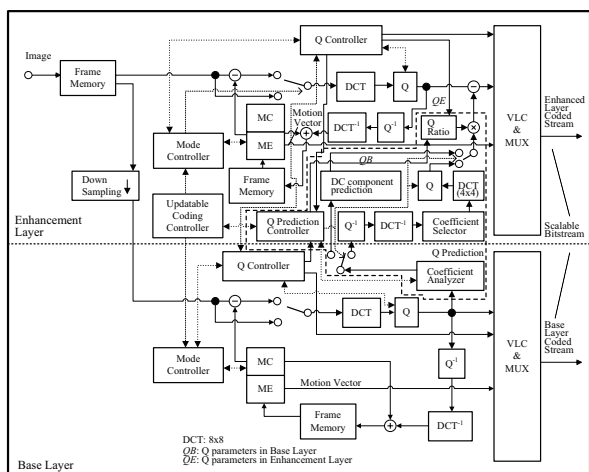

Fig. 5 Adaptive encoder of proposed methods

Consequently, considering the speed of prediction process, 4x4 DCT and prediction of proposed method is available, but it depends on the accuracy of q parameters for image quality, and the lower the quality, the more effective the prediction scheme used dc component only. Consequently, we can know that the prediction method using all DCT coefficients is not always efficient, and simple prediction of dc components only is available.

In this study, we analyze the coding efficiency of USVC from the viewpoints of entropy of differential data and the relation of q parameters in each layer. Finally, we will consider the adaptive encoder in Fig. 8.

#### 4. Conclusions

We had proposed “the concept of updatable scalable video coding (USVC)”, considering the functionality of video data. It shows the renewal of video quality for video data from the viewpoints of coding distortion and image resolutions and so on.

In this study, we focus on data prediction of DCT coefficient domain, the coding efficiency of USVC for the change of quantization accuracy using quantization parameters based on coding controller. Especially, SNR scalable and spatial scalable coding types are used. In the theoretical approach, the prediction coding of differential data among layers is proposed newly.

By the simulation results, the relation between the coding tendency of some test sequences and quantization parameters in low quality and high quality layers are shown by comparison between SNR and spatial coding types. In the intra mode, the part information of DCT coefficients, such as, only dc or 4x4 coefficients included this in DCT domain are more available rather than all DCT coefficients in low resolution. As further study, there are the practical coding simulations of layer video

coding, the coding decision method of hierarchical video coding based on USVC and the other scalable methods, such as FGS.

#### References

- [1] ISO/IEC 11172-2, Coding of moving pictures and associated audio for Digital Storage (1993).
- [2] ISO/IEC 13818-2, Information technology - Generic coding of moving pictures and associated audio information: Video, Recommendation H.262 (1995).
- [3] ITU-T, ITU-T Recommendation H.263, Video coding for low bitrate communication version 1 (1995).
- [4] ISO/IEC 14496-2, Information technology - Coding of audio-visual objects - Part 2 (1999).

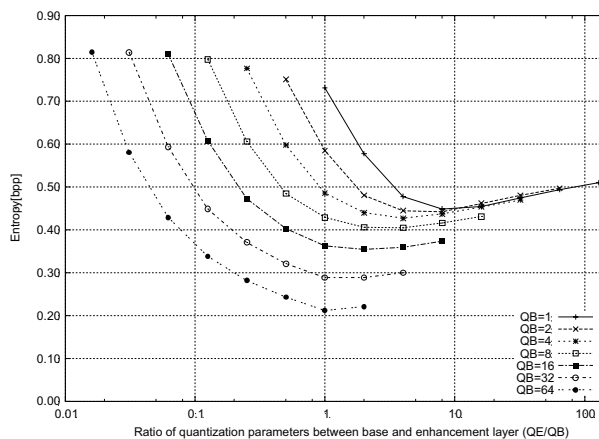

(i) ballet

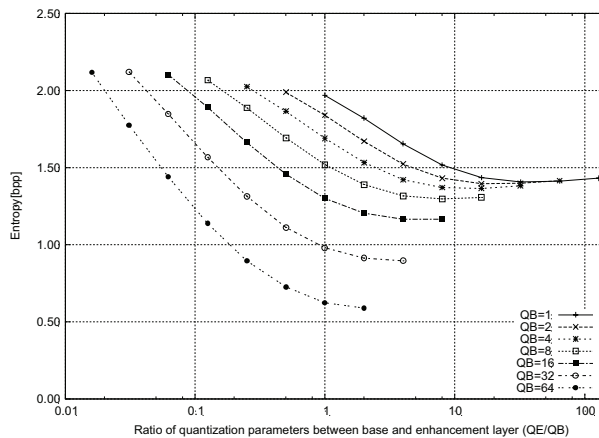

(ii) bicycle

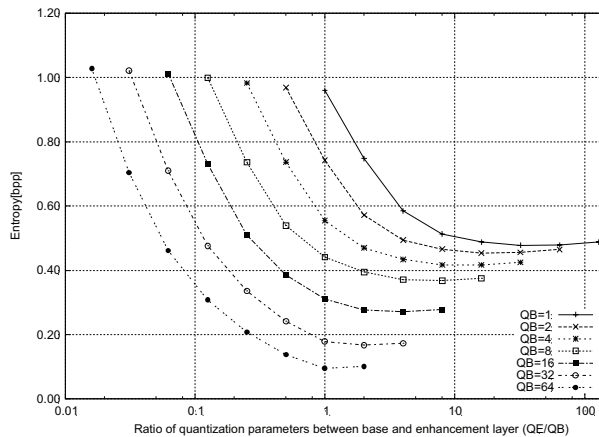

(iii) football

Fig. 6 Spatial coding type (base)

[5] ISO/IEC 14496-10, Information technology - Coding of audio-visual objects - Part 10: Advanced Video Coding (2006).  
 [6] ISO/IEC JTC1, MPEG93/457, Test Mode 5 (1993).  
 [7] M. Kodama, H. Tominaga, "Updatable Scalability of Moving Pictures and its Evaluation", IEICE, vol.J80-B-I, 2, pp.98-105 (1997).  
 [8] M. Kodama, S. Suzuki, "Consideration of Contents Utilization Time in Multi-Quality Video Content Delivery Methods with Scalable Transcoding", IEICE Trans. on IS, E88-D,7, pp.1587-1597 (2005).  
 [9] T. Wiegand, H. Schwarz, et al., "Rate-constrained coder control and comparison of video coding standards", IEEE Trans. on CSVT, 13, 7, pp.688-703 (2003).  
 [10] F. Kai-Tat and S. Wan-Chi. "DCT-based video downscaling transcoder using split and merge technique". IEEE Trans. on Image Processing, 15, 2, pp. 394-403 (2006.2).

[11] S. Bo. "Submacroblock motion compensation for fast downscale transcoding of compressed video". IEEE Trans. on CSVT, 15, 10, pp. 1291-1302 (2005.10).  
 [12] H. Shu and C. Lap-Pui. "The realization of arbitrary downsizing video transcoding". IEEE Trans. on CSVT, 16, 4, pp. 540-546 (2006.4).  
 [13] J. Lee and K. Chung. "Quantization/DCT Conversion Scheme for DCT-Domain MPEG-2 to H.264/AVC Transcoding". IEICE Trans., E88-B, 7, pp. 2856-2863 (2005.7).  
 [14] Y. Samba, S. Watanabe, et al., "High-Speed Distributed Video Transcoding for Multiple Rates and Formats". IEICE Trans., E88-D, 8, pp. 1923-1931 (2005.8).

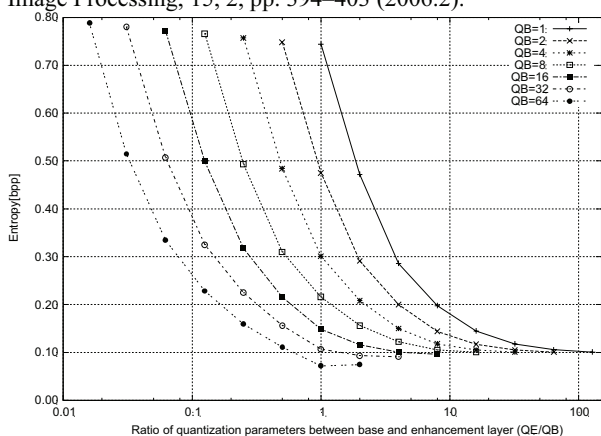

(i) ballet

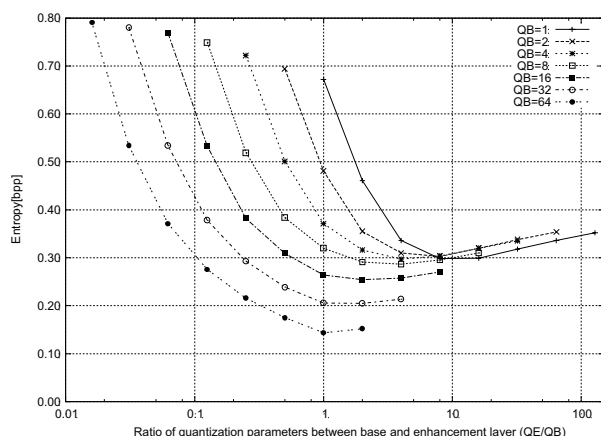

(i) ballet

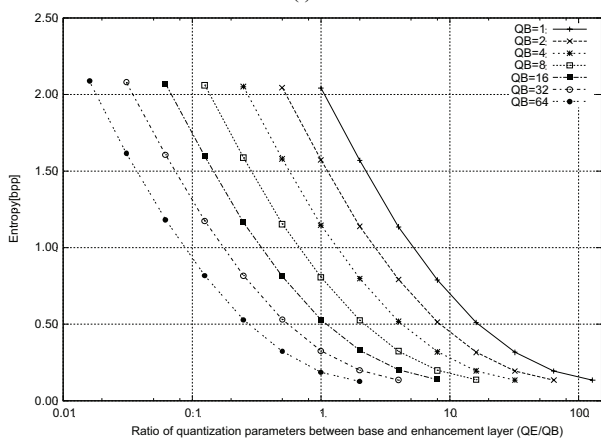

(ii) bicycle

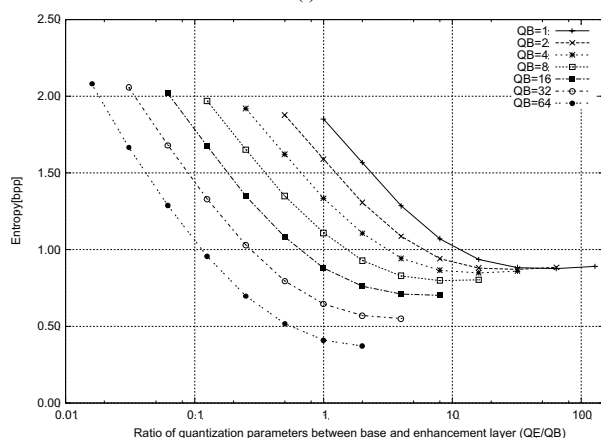

(ii) bicycle

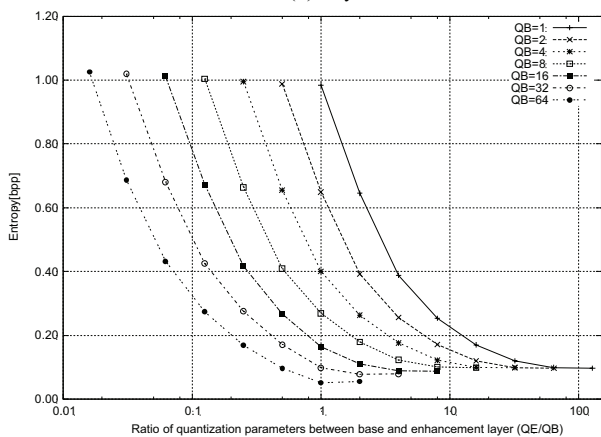

(iii) football

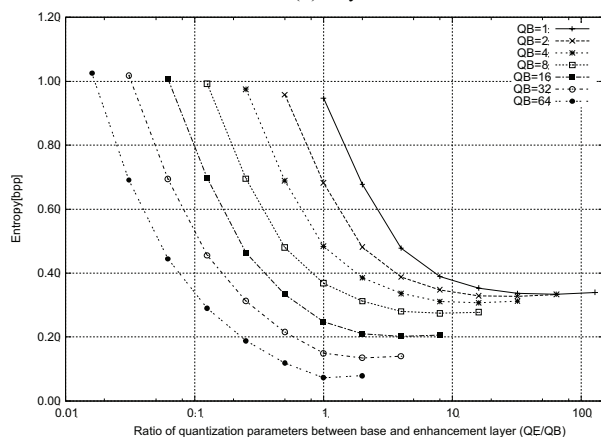

(iii) football

Fig. 7 Spatial coding type (dc only)

Fig. 8 Spatial coding type (4x4 DCT)