

Design and Layout of CMOS interface circuit for measuring photoplethysmogram

WooRam Lee¹, WanJik Lee², ChangSoo Won³, SangHee Son⁴, WonSup Chung⁵, and KyoungRok Cho⁶
^{1, 2, 3, 4, 5} Department of Electronics and information Engineering, Cheongju University

586 Deaseong-Ro, Sangdangu, Cheongju City, Korea

⁶ Department of Computer and Communication Engineering, Chungbuk National University

410 Sungbong-Ro, Heungduk-Gu, Cheongju City, Korea

E-mail: ¹00470289@cju.ac.kr, ²007111072@cju.ac.kr, ³wcs79@cju.ac.kr, ⁴shson@cju.ac.kr, ⁵circuit@cju.ac.kr, ⁶krcho@chungbuk.ac.kr

Abstract: A CMOS interface circuit for measuring PPG(Photoplethysmogram) is proposed and designed by using current-control Schmitt trigger in this paper. This circuit detects the blood beat using PPG which occurs in bloodbeat sensor and composed of analog and digital parts. Current signal of sensor is converted into voltage in analog parts and then converted into digital signal in digital parts. Compared to the conventional method, operation speed is increased and linear error is diminished by applying OTA(Operational transconductance amplifier) to Schmitt trigger circuit and oscillator. Also, proposed and designed circuit has some features of low power consumption, simple structure and high resolution compared with previous method.

1. Introduction

Generally, PPG is called "Photoplethysmogram" and it means the reflex wave from the edge of finger or wrist after implanting the light such as an infrared ray. Flowing blood stream in the body can be measured by using the PPG detection system that composes of small quantity of LED and photo detector.

The change of blood volume is detected by measuring the PPG that is the reflex or penetrated wave from the incidence light such as a visible ray or an infrared ray to muscular tissue and it is measured in the finger and earlobe, etc. [1] ~ [3]

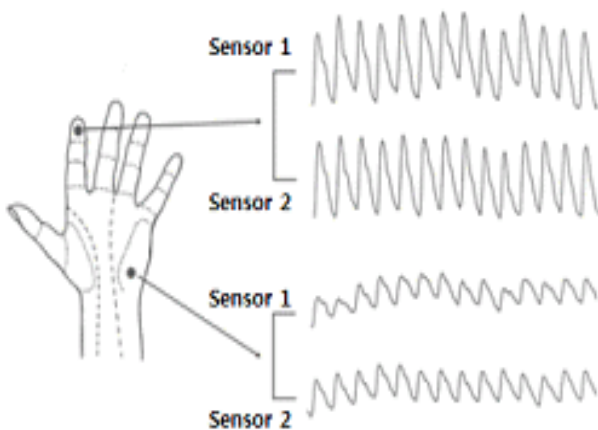

Figure 1. Detection region and detection pulse of PPG

To detect the PPG in the edge of finger in detection region of Fig. 1, sensor interface circuit for measuring PPG is designed by using photoelectric elements. Circuit and layout design is performed using a Magna/Hynix 0.35 um CMOS standard process.

2. Sensor Circuit Board for measuring PPG

In sensor circuit for measuring PPG, there is two-type circuits: voltage-output type & a current-output type. In this paper, we select a current-output type.

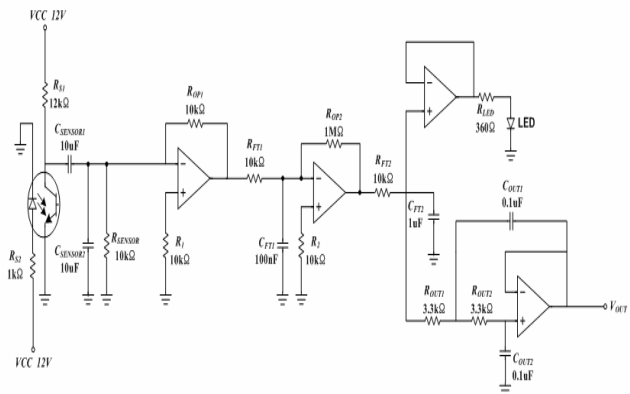
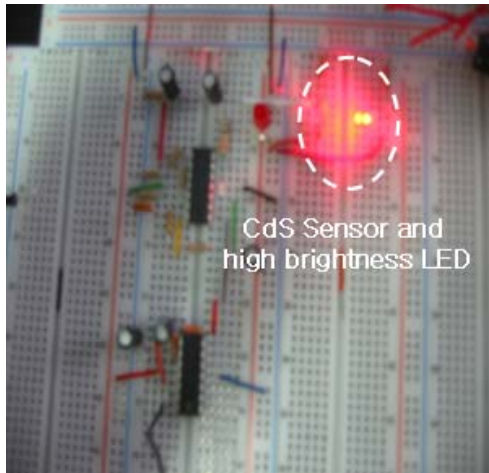

Figure 2. Proposed sensor circuit for PPG measurement

Sensor circuit is shown in Fig. 2. Performance properties of this circuit are as follows. PPG is detected by CdS photo sensor firstly and then amplifies it and passes it to the filter to eliminate the noise. Next, second amplification(inverting amplification) and low pass filter stage is needed to get the signal. Amplification stage is needed to amplify PPG that is small and irregular signal from finger and filter is needed to reduce the noise.

In measuring the PPG, the reason why CdS photo sensor use is its characteristics of changing the current strength depending on the penetrated light from body. If red high brightness LED is used as light source, it suppress the interference of other lights and then CdS measures only the values proportion to amount of bloodstream.

Fig. 3 shows the sensor circuit in board for PPG measurement and PPG measurement pulse. Operating the LED, CdS sensor operation is confirmed and sensor output current to the input of schmitt trigger through amplification and filtering is achieved. As shown in Fig. 3 (b), signal decreases due to decrement of light in the tissue during shrinking. On the contrary signal increase due to increment of light in the tissue during relaxation. From this, proposed and designed sensor circuit for measuring PPG operates well.



(a)

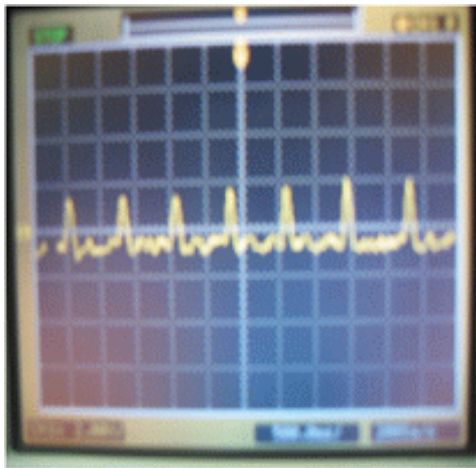

(b)

Figure 3. (a) sensor circuit in board for PPG measurement
(b) PPG measurement pulse

3. Design of CMOS Interface Circuit for measuring PPG

Living body sensors are various and typical sensors are blood sugar sensor, bloodstream sensor and blood beat (pulse) sensor. From the above sensors, interface circuit for measuring PPG in this study is designed based on the blood beat sensor. [4]~ [5]

CMOS interface circuit for measuring PPG is shown in Fig. 4. This circuit converts the analog sensor output signal into digital signal and display it to the meter. Circuit is divided into analog part and digital part. Analog part is composed of a bias circuit for comparison of voltage, current-controlled Schmitt trigger for comparing sensor output and square wave oscillator for creating clock. Digital part is composed of control logic for gaining Schmitt trigger output and segment converting circuit for down counter, latch, timer and display.

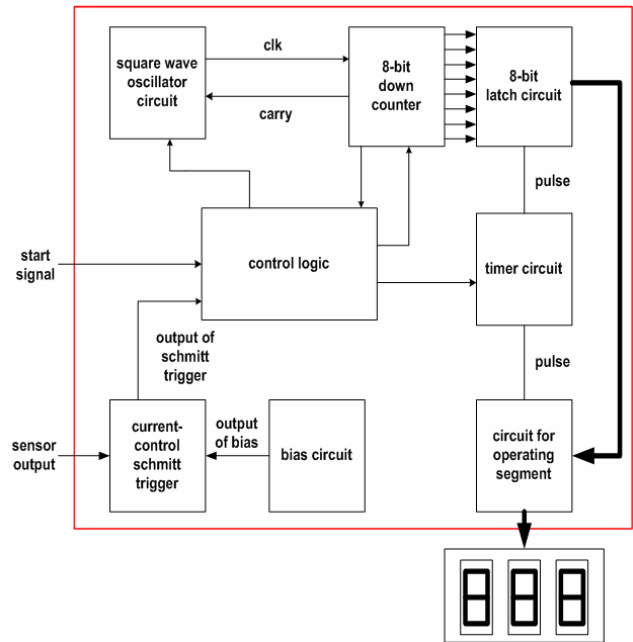

Figure 4. Block diagram of designed CMOS interface circuit

Input sensor output range is 0~75 μ A in the interface circuit and sensor operating voltages are setting to 3.3V for IC operation. Also digital output of interface circuit is 8 bits. Circuit is designed to have the resolution of 0.25 μ A/1 bit considering of the 8-bits digital output.

Circuit operation principles are as follows. If the PPG sensor output current is inputted to the current-controlled Schmitt trigger, Schmitt trigger output pulses compared with output voltages in the bias applies to J-K flip/flop in the control logic. Output pulse from J-K flip/flop operates a down counter through AND gate in the control logic and clock from square wave oscillator. Operating down counter, "HIGH" result is occurred and then it enables to timer through reverse output from J-K flip/flop and AND gate.

Timer give pulses (V_{OUT}) to latch and segment converting circuit. Inputting pulses to the latch, latch is shut down and save counter output. Segment converting circuit is operated by 'ON' switch at the same time. Finally saved data in the latch is displayed into 7-segment from segment converting circuit.

The main feature of proposed CMOS interface circuit is using the current-controlled Schmitt trigger circuit in this paper.

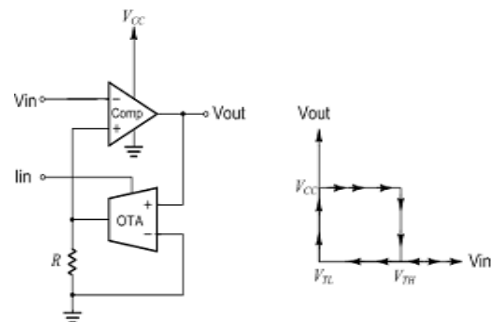

Figure 5. Designed current-control Schmitt trigger circuit

Current-controlled Schmitt trigger circuit converts sensor output current into pulse-type voltages. Fig. 5 shows the designed current controlled schmitt trigger circuit. Current-controlled schmitt trigger circuit is composed of a comparator and an OTA. From the graph in fig. 5, low threshold voltage (V_{TL}) of current-controlled schmitt trigger is corresponding to sensor output current 0 [A] and sensor is not operating.

$$V_{TL} = 0 \tag{1}$$

When sensor is operating, high threshold voltage (V_{TH}) of current-controlled schmitt trigger is corresponding to sensor output current I_{SENSOR} .

$$V_{TH} = I_{SENSOR} R \tag{2}$$

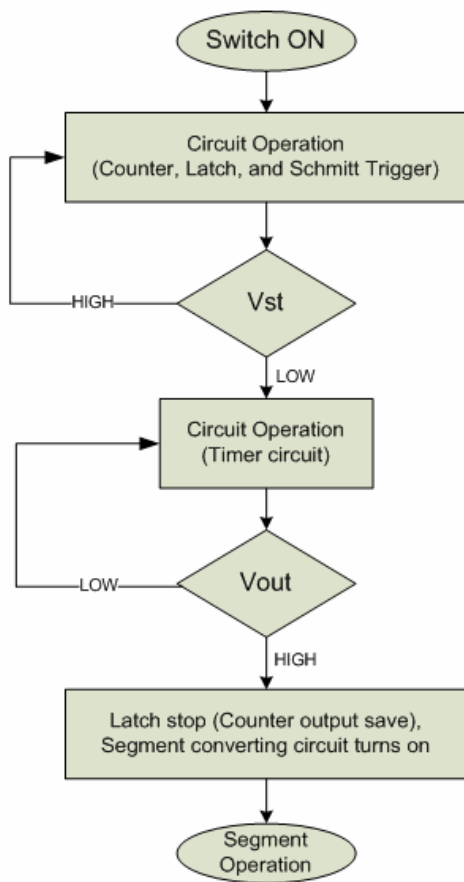

Figure 6. Operation flowchart of circuit

Overall principles and predicted waveforms are shown in fig. 6 and fig. 7. Turning the switch ON, schmitt trigger starts and counter is acting on. Counter output is saved in the 8-bit latch continuously. If sensor is operating and its output current is changing, schmitt trigger receiving the bias voltage and sensor output currents generates the pulse (V_{ST}).

If schmitt trigger output (V_{ST}) is 'low', next step are operating. But it is 'high', existing state are keeping on. When V_{ST} is 'low', timer is operating. When V_{OUT} is 'high',

counter outputs are saved by stopping the latch and segment converting circuit turns on. Then, digital values converting into 7-segment are outputted.

In fig. 7, when sensor output is higher than bias voltage by comparing sensor output voltage and bias reference voltage, schmitt trigger circuit generates the pulse type waveform and J-K flip/flop is starting in down-edge of schmitt trigger and down counter starts to counting. Timer circuit controls the operation of latch and segment circuit in down-edge of J-K flip/flop.

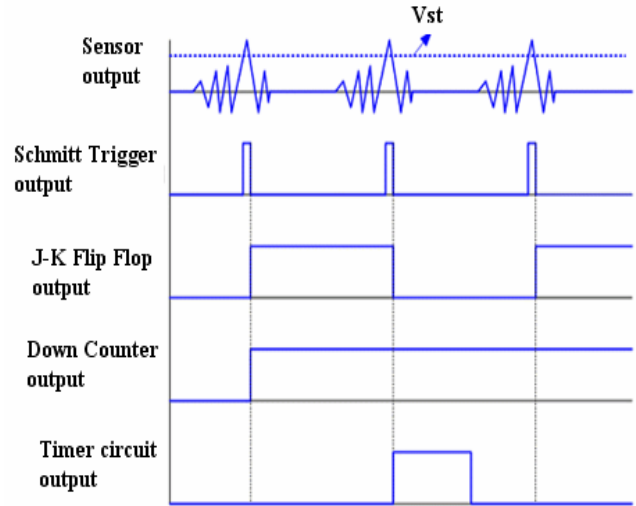

Figure 7. Estimated pulse waveform of circuit

4. Simulation Results and Analysis of CMOS Interface Circuit for measuring PPG

Fig. 8 shows the simulation results of proposed circuit. Segment output result is confirmed by the number of 1 cipher in random frequency.

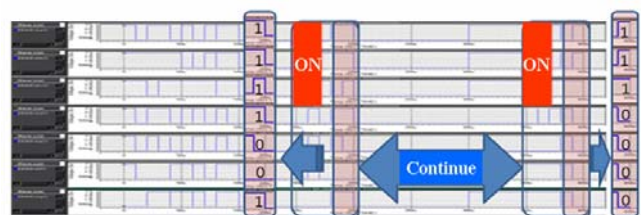

Figure 8. Data simulation results of proposed circuit

The data in the present ON zone is keeping before next ON zone. That is to say, display data in present zone is from the old ON zone. But data in continuous zone is changing continuously and final data in continuous zone is displayed in next ON zone. Above operations are repeated again. In fig. 8, segment data of '1111001' means '3' in 1st ON zone and segment data of '1110000' means '7' in 2nd ON zone. This circuit is made by board and board test results are acquired from experiment

Fig. 9 shows the experimental results of board test. Really seven board outputs is required but oscilloscope only display two outputs. In fig. 9, upper data is corresponding

to the data of 1-bit and lower data is corresponding to the data of 7-bit.

IC design of CMOS interface circuit for measuring PPG in fig. 10 is executed and verified by using Magna/Hynix 0.35 μ m CMOS standard process.

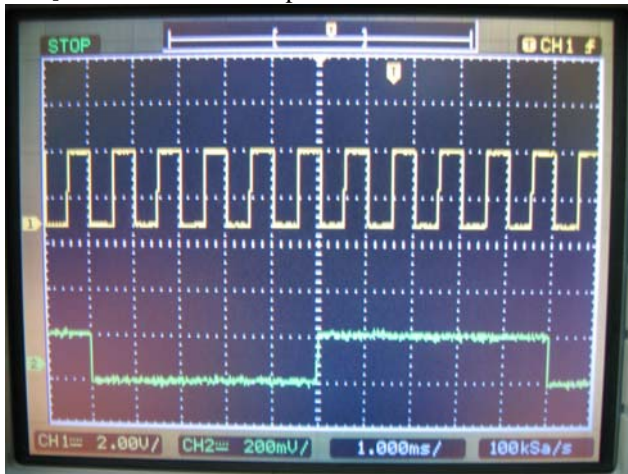

Figure 9. Board experiment results of proposed circuit

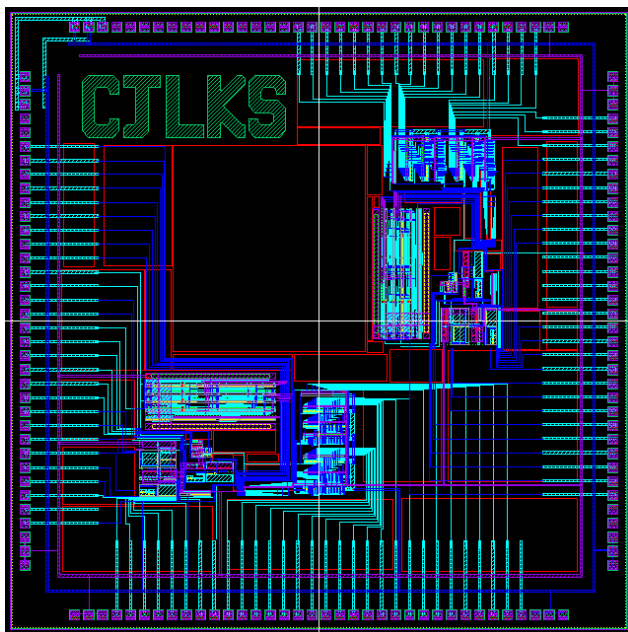

Figure 10. IC Layout of CMOS interface circuit for PPG measurement

5. Conclusion

Proposed CMOS interface circuit for measuring PPG is an interface circuit for detecting the blood beat using PPG and its operation speed is higher than previous circuit. Converting linear errors are reduced also. Sensor output current is converted into pulse width by current-controlled schmitt trigger circuit. Higher resolution will be acquired using more precise counter. Proposed CMOS interface circuit for measuring PPG will be applied to not only CMOS interface circuit for measuring PPG but also interface circuit of other various sensor.

Acknowledgments

"This work was supported by the Korea Research Foundation Grant funded by the Korean Government (MOEHRD)" (The Regional Research Universities Program/Chungbuk BIT Research-Oriented University Consortium).

References

- [1] Drzewiecki, G. 2000. Noninvasive arterial blood pressure and mechanics, pp. 1-16, In Bronzino, J.D. (eds.), The Biomedical Engineering Handbook, Vol. 1. CRC Press, Boca Raton, Florida.
- [2] Fronck, A. 1989. Noninvasive diagnosis in vascular disease. McGraw Hill, New York.
- [3] Ito, H., K. Yamakoshi, and T. Togawa. 1976. Transthoracic admittance plethysmography for measuring cardiac output. J. Appl. Physiol. 40, 451-454.
- [4] L. Ravezzi, D. stoppa, G.-F. Dalla Betta "Current-mode A/D converter", Electronics Letters, vol.34, Issue 7, pp.615-616, April 1998.
- [5] Y. H. Ghallab, W. Badmy "A new differential pH sensor current mode read-out circuit using two operational floating current conveyor", IEEE Proceedings of Biomedical Circuits and systems 2004, vol.1/5, pp.13-16 Dec.2004.