

Measurement Site and Applied Pressure Consideration in Wrist Photoplethysmography

Eun Geun¹, Hyun Heo², Ki Chang Nam³ and Young Huh⁴

^{1,2,3,4}Korea Electrotechnology Research Institute (KERI)

1271-19, Sa-dong, Sangnok-gu, Ansan, Gyeonggi-do, Korea

E-mail: ¹kimeg917@keri.re.kr, ²gigus1@nate.com, ³chadol@keri.re.kr, ⁴yhuh@keri.re.kr

Abstract: The objective of this study is to describe preliminary evaluation of a new optical reflectance sensor module with air pressure cuff. In order to improve PPG signals from the wrist as an example of wearable PPG, the optical reflectance sensor module includes two identical photodiodes and a pair of red and infrared LED. The sensor module was packaged inside of a cuff to demonstrate the effects of pressure applied to reflectance probe at the radial artery in the wrist. PPG signals with large amplitude were measured when the induced cuff pressure was close to mean blood pressure. This result will be applied to development of a wrist type healthcare device.

1. Introduction

It is well established that recordings of the beat-to-beat variations in heart rate can be a useful diagnostic technology in cardiovascular medicine [1]. Although the majority of applications use ECG as the sensing mechanism or cardiac dynamics, it has been noted that photoelectric plethysmography [2], also known as photoplethysmography (PPG), can also be employed to derive essentially the same information [3]. PPG is a non-invasive method of detecting the cardio-vascular pulse wave that propagates through the body. The cardiovascular wave is stimulated by each cardiac contraction, and detected in the periphery using a light source and a detector. Clinical applications of PPG technology include the measurement of heart rate [4, 5], peripheral vascular properties [6-8], blood pressure [9, 10], and autonomous nervous activity [11, 12].

Photoplethysmography(PPG) is measured by analyzing the pulsatile components of the detected red and infrared plethysmograms which make use of transmitted or reflected light intensities. In reflectance, the light from the LEDs enters the tissue, is scattered by both the moving red blood cells and the non-moving tissue, and a part of this back scattered light is detected by the photodiode(PD)[13].

Reflectance(back-scatter) PPG has potential advantages compare with transmission PPG. The probe can be placed at virtually any site on the skin, because the light sources and the detector(s) are integrated side by side in the probe. Therefore, the probe can even be used on locations where light cannot be transmitted[14].

However, there are some problems in the reflectance PPG method. The major practical limitation is the comparatively low-level photoplethysmograms recorded from low-density vascular areas of the skin. Therefore, the feasibility of reflectance PPG depends on the ability to design an optical reflectance sensor that can reliably detect sufficiently strong reflectance photoplethysmograms from various locations on the skin[15]. In order to partially

overcome these limitations Dassel et al. applied pressure on the probe to increase the accuracy of reflectance pulse oximetry at the forehead[14].

Measuring with high-quality data on the wrist is also difficult and often requiring the application of pressure to the sensor in order to reduce the physical contact between the sensor and the wrist[16]. Furthermore, sensor configuration and power consumption play a important role in the design of a wearable bio -instrumentation device[17].

To implement wrist wearable healthcare device, we have developed an optical reflectance sensor module that includes an array of two identical photodiodes and a pair of red and infrared LED. The sensor module was packaged inside of a cuff to demonstrate the effects of pressure applied to reflectance probe at the radial artery in the wrist.

The objective of this study is to describe preliminary evaluation of a new optical reflectance sensor module with air pressure cuff, in order to improve PPG signals from the wrist area as an example of wearable PPG.

2. Method

2.1 Experimental Setup

Fig. 1 shows the general PPG block diagram. The system was designed to detect red and infrared (IR) signal. The photodiodes(PDs) detected radiation back scattered by the tissue from both infrared and red LED and delivered output current proportional to the detected radiation level. The analog signals from the common current to voltage converter were subsequently separated into IR and red components by signal conditioning circuitry(Fig.2) Amplified and filtered analog signal components were measured by a oscilloscope (TDS3014, Tektronix).

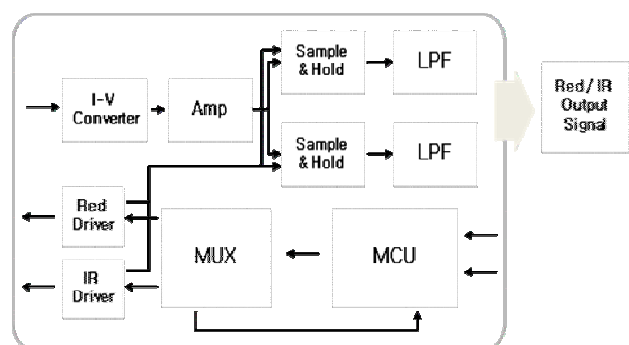

Fig.1. System block diagram of PPG.

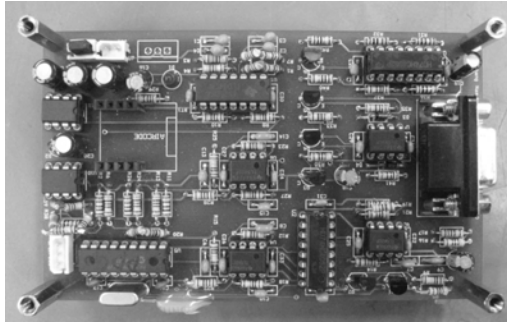

Fig.2. Developed PPG circuit board.

The constructed reflectance sensor consists of 2 silicon PD chips(active chip area : 3mm x 3mm) and a pair of red (660nm)and IR(940nm) LEDs. LEDs were positioned between identical two PDs as shown in Fig. 3,4. The distance of PDs was set to 6 mm. The optical sensor module was packaged inside of a air pressure cuff.

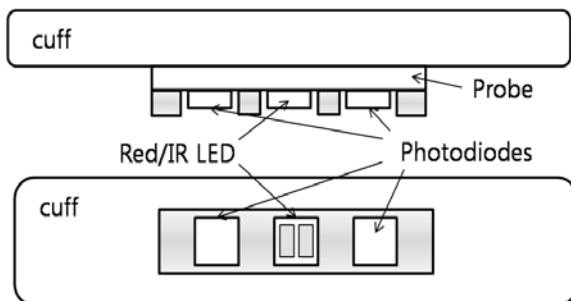

Fig.3. Air pressure cuff and reflectance PPG probe; side (top) and bottom (bottom) view.

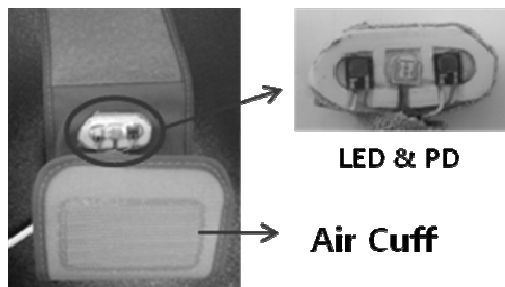

Fig.4. Constructed sensor module (Air pressure cuff and reflectance PPG probe)

2. 2 Experiment

One volunteer was participated in preliminary measurement. Subject was informed about the purpose and procedure of the study and asked written consent. During the measurement of PPG with wrist cuff, air pressure was induced by gradually from 0 to 140 mmHg occluding the radial artery at increment of 20 mmHg. Pressure was monitored with a analog sphygmomanometer. In the event the volunteer felt uncomfortable, the measurement process was stopped.

Three experiments performed to compare the PPG amplitudes measured by the reflectance sensor probe. In sensor positioning experiment, the probe was mounted on the palmer side of the wrist. The sensor module was

centered at three points as shown in Fig.5 and the measured amplitudes of red and IR signal were compared. In the second experiment, the probe was mounted on the finger, the palm of the hand and palmer side of the wrist. In the third experiment, sensor was located at '2' in Fig.5 and the amplitudes of PPG were compared according to pressure application by air cuff.

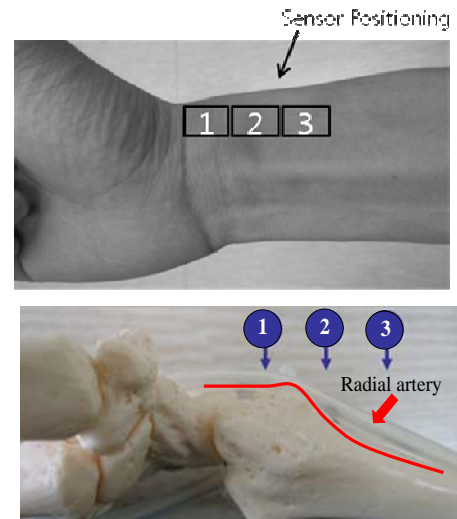

Fig.5. Sensor positioning on the wrist (top) and anatomical position in bone (bottom)

3. Results & Discussion

Fig.6, 7, and 8 shows the measured PPG at three point '1, 2, and 3' in the wrist described in Fig. 5, respectively. There were no significant amplitude difference among three measurement positions except that it seems to be less amplitude at '3'. It is thought that sensor attachment on the wrist is affected by radius bone structure and radial artery location.

The PPG signal from widely distributed portion of the capillaries parts such as finger or palm was relatively stable. But the results measured at another location of the wrist got a weak signal. Even though the PPG is easily measurable at finger, extensional finger probe is necessary. To implement a wrist type device, other possible measurement positions which is necessary of extensional probe option was exclude from the experiment.

Fig. 9 shows the measured red LED reflectance signal by applying pressure on the wrist. Naturally, maximum amplitude changes were shown when the induced pressure was close to the mean arterial blood pressure of the subject. It is considered that air cuff module can be used for stable attachment between sensor and skin.

PPG signal from radial artery might different from other subject because every person have different radial artery location and depth. Furthermore, PPG signal greatly distorted depending on applied pressure. Through experiments, it was verified that proper location of the sensors and pressure on the the skin surface are important element on stable PPG measurement.

4. Conclusion

The objective of this study is to describe reflectance sensor module configuration with air pressure cuff, in order to improve PPG signals from the wrist area as an example of wearable PPG.

Measuring PPG on the wrist is difficult. Because people have different position and depth of radial artery each other. The position of sensor and application of pressure to the sensor in order to reduce the physical contact between the sensor and the wrist affect on the magnitude of PPG. As preliminary study to implement wrist wearable device, we have developed an sensor module that includes an optical reflectance sensor and air cuff. Further study is necessary to find optimal LED and PDs array to increase the measurement efficiency. This result will be applied to development of a wrist type healthcare device.

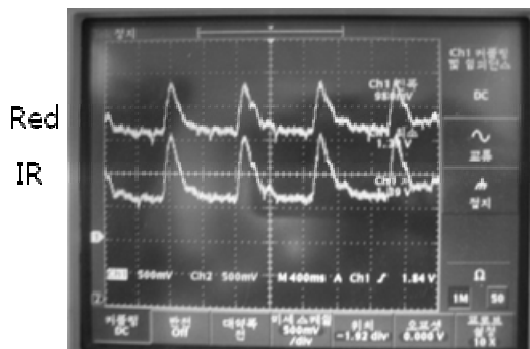

Fig.6. PPG signal measured at '1' in Fig. 5

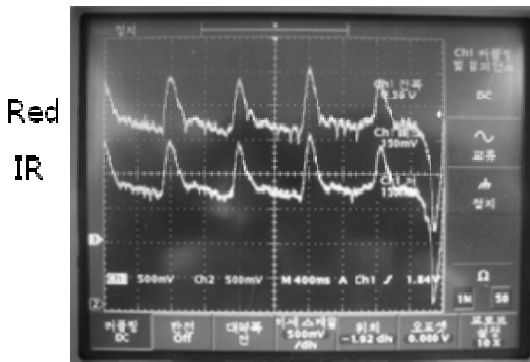

Fig.7. PPG signal measured at '2' in Fig. 5

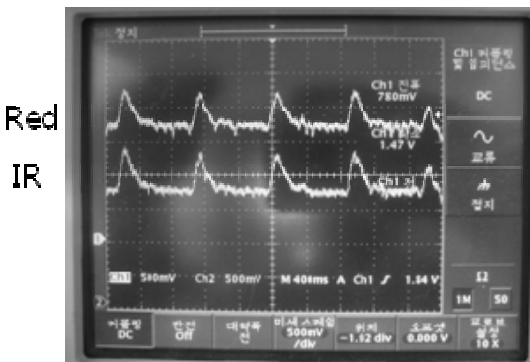

Fig.8. PPG signal measured at '3' in Fig. 5

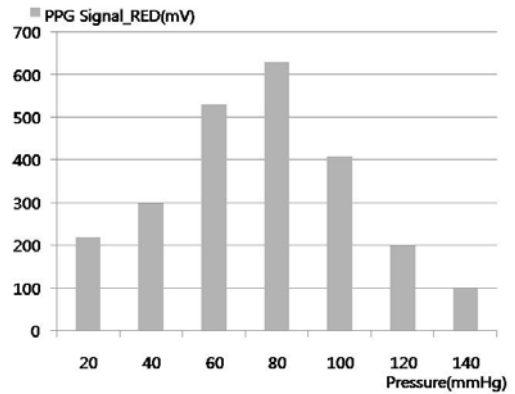

Fig.9. PPG amplitude versus pressure applied to the probe

References

- [1] M. Malik, "Guidelines: Heart rate variability Standards of measurement, physiological interpretation, and clinical use", *Eur Heart J.*, vol. 17, pp354-38, 1996
- [2] A. B. Hertzman, "Photoelectric plethysmograph of the finger and toes in man", *Proc. Soc. Exp. Biol. Med.*, vol. 37, pp. 1633-1637, 1937.
- [3] M. J Drinnan, J. Allen, and A. Murray, "Relation between heart rate and pulse transit time during paced respiration", *Physiol. Meas.* vol. 22, pp425-432, 2001
- [4] K. Nakajima, T. Tamura, and H. Miike, "Monitoring of heart and respiratory rates by photoplethysmography using a digital filtering technique", *Med. Eng. Phys.*, vol. 18, pp. 365-372, 1996.
- [5] A. Johansson, P. A. Oberg, and G. Sedin, "Monitoring of heart and respiratory rates in newborn infants using a new photoplethysmographic technique", *J Clin. Comp.*, vol. 15, pp. 461- 467, 1999.
- [6] M. Nitzan, H. d. Boer, S. Turivnenko, A. Babchenko, and D. Sapoznikov, "Spontaneous oscillations in the peripheral circulation system, as measured by photoplethysmography", *Proc. SPIE*, vol. 2328, pp. 188-195, 1994.
- [7] E. A. Lopez-Beltran, P. L. Blackshear, S. M. Finkelstein, and J. N. Cohn, "Non-invasive studies of peripheral vascular compliance using a non-occluding photoplethysmographic method", *Med. Biolog. Eng. Comp.*, vol. 36, pp. 748-753, 1998.
- [8] Y. Tardy, J. J. Meister, F. Perret, H. R. Brunner, and M. Arditi, "Noninvasive estimate of the mechanical properties of peripheral arteries from ultrasonic and photoplethysmographic measurements", *Clin. Phys. Physiol. Meas.*, vol. 12, pp. 39-54, 1991.
- [9] K. Meigas, R. Kattai, and J. Lass, "Continuous blood pressure monitoring using pulse wave delay", presented at 23rd Annual International Conference of the IEEE Engineering in Medicine and Biology Society, Oct 25-28 2001, Istanbul, Turkey, 2001.
- [10] X. F. Teng and Y. T. Zhang, "Continuous and Noninvasive Estimation of Arterial Blood Pressure Using a Photoplethysmographic Approach", presented at A New Beginning for Human Health: Proceedings of the 25th Annual International ESC DIVISION RESEARCH 2005 Department of EEE, Loughborough

University 42.

- [11] J. Naschitz, R. Itzhak, N. Shaviv, I. Khorshidi, S. Sundick, H. Isseroff, M. Fields, R. Priselac, D. Yeshurun, and E. Sabo, "Assessment of cardiovascular reactivity by fractal and recurrence quantification analysis of heart rate and pulse transit time", *J. Hum. Hypert.*, pp. 111-118, 2003.
- [12] M. Nitzan, A. Babchenko, B. Khanokh, and D. Landau, "The variability of the photoplethysmographic signal - a potential method for the evaluation of the autonomic nervous system", *Physiol. Meas.*, vol. 19, pp. 93-102, 1998.
- [13] J.G. Webster, *Design of Pulse Oximeters*, UK, 1997.
- [14] Dassel ACM, Graaff R and Sikkema M, "Reflectance pulse oximetry at the forehead improves by pressure on the probe", *J. Clin. Monit.*, Vol. 11, No. 4, pp237-244, 1995.
- [15] Y.Mendelson and M.J.McGinn, "Skin reflectance pulse oximetry : in vivo measurements from the forearm and calf", *J. Clin. Monit.*, Vol. 7, No. 1, pp. 7-12, 1991.
- [16] David Thompson and Steve Warren, "A Small, High-Fidelity reflectance Pulse Oximeter", *The 114th Annual ASEE Conference in Hawaii*, AC2007-2420, 2007.
- [17] Y.Mendelson and C.Pujary, "Measurement Site and Photodetector Size Considerations in Optimizing Power Consumption of a Wearable Reflectance Pulse Oximeter", *The 25th Annual International Conference of the IEEE EMBS in Cancun*, pp.3016-3019, 2003.