

Implementation of emulator for evaluating the RF characteristics of active RFID

Taeseung Song¹ and Joon Lyou²

¹ Electrotechnical Center, Korea Testing Laboratory
222-13 Guro-dong, Guro-gu, Seoul 152-718, Korea

² Department of Electronics Engineering, Chungnam National University
220 Gung-dong, Yuseong-ku, Taejeon 305-764, Korea

E-mail: ¹ tssong@ktl.re.kr, ² jlyou@cnu.ac.kr

Abstract: In this study, an emulator for standard conformance test on active RFID has been designed and substantiated. The developed evaluating device is a standard signal generator with reproducibility for standard conformance testing. It was designed so that the emulator would give commands or responses to the reader and tag to be tested, and that can check the malfunction of the reader and the tag using a standard signal. Further, some random functional changes, (i.e., transmission output, frequency shift, bit rate accuracy), have been made to the evaluating device to check for various errors and malfunctions raised in the testing sample for improvements to be made.

Keyword: RFID, emulator, RF characteristic, reader, tag

1. Introduction

Radio Frequency Identification (RFID) uses a smart tag capable of transmitting data by radio. RFID technology has two major areas of application. The first application is the handheld non-contact IC cards for pay phones, commuter rail passes, etc. The second application is in the field of supply chain management (SCM) in which RFID tags are used to manage the flow of products during physical distribution by being attached to containers, pallets or products. The RFID tag herein is divided into the passive type and the active type, according to the presence of a battery. A passive tag has the advantages of a short identification distance, a low price, and semi-permanent usage capabilities, because it uses an RF signal received from the reader as energy. On the other hand, an active tag is expensive, and has a limited life because the life span of the power supply section inside the tag is limited. However, the active tag has a long identification distance, and simultaneously overcomes the passive tag's weak points, i.e., the fragility of metal materials.

In an active RFID system, compared to a passive RFID system, interoperability between developed readers and tags is not fully achieved. Although these readers and tags were developed under same standards, in fact examples of impossible identification between readers and tags occurred because each reader or tag was designed depending on understandability of the corresponding company's engineer specifications. Accordingly, an emulator able to maintain interoperability between readers and tags is indispensable. In this study, the aforementioned necessity was recognized. As a basic study for a solution, hardware and software for an emulator to evaluate the conformance of an active RFID system were designed and implemented by FPGA module and C-language. To verify performances of designed emulator, simulation using the MATLAB was executed.

With emulator system for active RFID, many parameters such as spectrum masks, transmitting power, data waveform and other RF characteristics can be analyzed. Furthermore it can be applied to standard conformance tests for the evaluation of developed reader and tag.

2. Design Concepts

An active RFID emulator has a frequency shift keying (FSK) type direct conversion receiver. As the same frequency is used for transmitting and receiving signals, signals can be determined by a Time Division Duplex (TDD). The following Figure 1 shows the structure of the transceiver for an active RFID emulator.

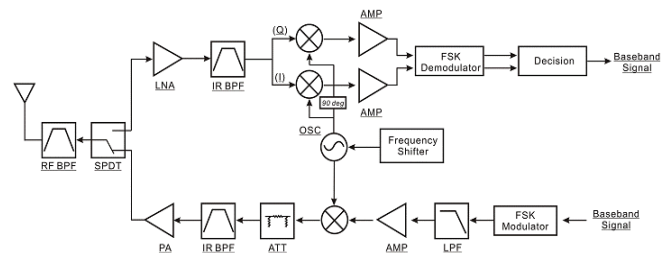

Fig. 1. A structure of transceiver for active RFID emulator.

With regards to receiving power, a receiver is designed so that it can have 5.6 dBm and reduced peak power when antenna power is 0 dBi. When the effective radiation power of an active RFID tag is 5.6 dBm, the receiving power of an RFID reader, which can be obtained from a distance of d in free space, is as shown in the following formula, where λ is the wavelength of the carrier wave. Accordingly, the receiving power, depending on distance, is as shown in Figure 2.

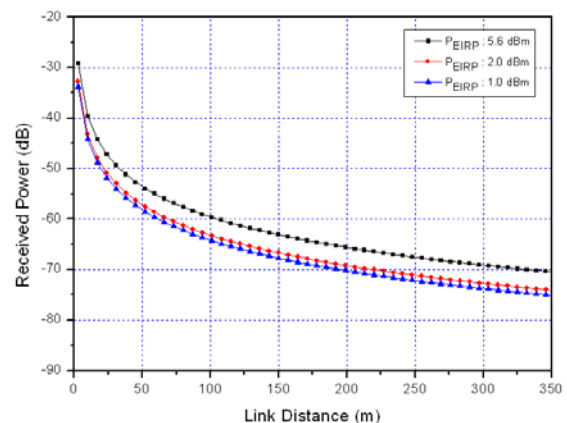

Fig. 2. The receiving link power depending on distance.

$$P_{rec} = P_{EIRF} G_{rec} \left(\frac{\lambda}{4\pi d} \right)^2 \quad (1)$$

When a transmitter has a transmitting power of 5.6 dBm, it is shown that the power received at a distance of 100 m is -60 dB. Accordingly, to ensure the identification distance of at least 100 m, a receiving section requires a receiver sensitivity exceeding -60 dBm.

The receiver sensitivity is the minimum signal input required for generating a Signal to Noise Ratio (SNR) or Bit Error Rate (BER) of the receiver output to conform to standards. In other words, it is a characteristic that indicates how faint a signal can be satisfactorily restored by the receiver. The receiver sensitivity is determined by the Thermal Noise Power (N), depending on the receiver input resistance, the Noise Figure (NF), indicating the ratio of internal noise, the Noise Bandwidth (B) of the receiver, and the SNR of the required output.

$$MDS = (N_{in})_{dBm} + (NF)_{dB} + (10 \log B)_{dB} \quad (2)$$

$$(P_{min})_{dBm} = MDS_{dB} + CNR_{dB} \quad (3)$$

When the Noise Figure (NF) of a system is 10 dB, the Minimum Detectable Signal (MDS) becomes -107 dB. The receiver sensitivity, representing the Carrier to Noise Ratio (CNR) of 3 dB, becomes at least -104 dBm.

$$N_{in} = kT = (1.38 \times 10^{-23} \text{ joules} / K) \times 290K = -174_{dBm} \quad (4)$$

$$(NF)_{dB} = (SNR_{in})_{dB} - (SNR_{out})_{dB} = 10 \log F \quad (5)$$

$$F_{total} = F_1 + \frac{(F_2 - 1)}{G_1} - \frac{(F_3 - 1)}{G_1 G_2} + \dots \quad (6)$$

Lastly, the Carrier to Noise Ratio (CNR) is expressed as per the following formula, where E_b/N_0 is the ratio (dB) of the signal power per 1 bit of data to noise power. R is the data transfer rate and B is the bandwidth. With regards to a non-coherent FSK system, bit error probability is as shown in per following formula.

$$\left(\frac{C}{N} \right)_{dB} = 10 \log \left(\frac{R \times E_b}{B \times N_0} \right) = \left(\frac{E_b}{N_0} \right)_{dB} - (PG)_{dB} \quad (7)$$

$$P_E = \frac{1}{2} e^{-\frac{E_b}{N_0}} \quad (8)$$

In this study, an emulator for evaluating the standard conformance of active RFID has a 500 kHz bandwidth (B) and a 27.7 kbps data transfer rate (R). When the bit error rate (BER) is 10 to 6, an E_b/N_0 of approximately 14 dB is required. Accordingly, the required Carrier to Noise Ratio (CNR) is 1.435 dB.

3. Simulation Results

To analyze the system of the emulator for evaluating a 433 MHz active RFID, a simulator was configured using Matlab/Simulink. Each communication block substantiated in the simulator was modeled so that it would be similar

with the parts of an actually produced evaluating system. Especially for the mixer, an analog part, its characteristic parameter was directly measured, with the measured value applied to the simulator.

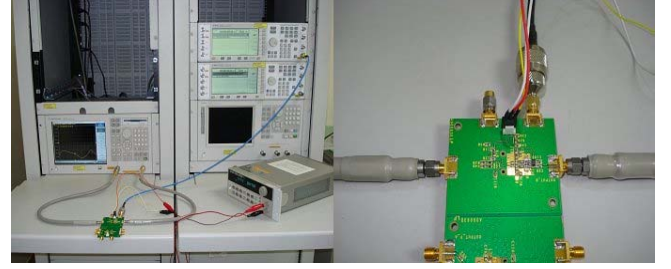

Fig. 3. Measurement of mixer's characteristic parameter.

The simulator generates a random signal with Manchester Coding. The signal is transmitted after FSK modulation. The transmitted signal is demodulated in consideration of the loss of free space, and is then configured so that the error rate can be calculated by comparison to the generated signal. At that time, the data transmission rate is 27.7 kbps. After FSK modulation is conducted so that a frequency shift of 50 kHz can be obtained, the signal to have passed through a low-pass filter is input to the RF transmission module, its center frequency becomes 433.92 MHz, and a transmission signal, including a 200 kHz occupied frequency bandwidth, is generated. The generated transmission signal's receiving power should not exceed 5.6 dBm according to domestic regulations when antenna gain is 0 dBi. The following Figure 4 shows the spectrum of transmission and reception signals generated in the produced simulator.

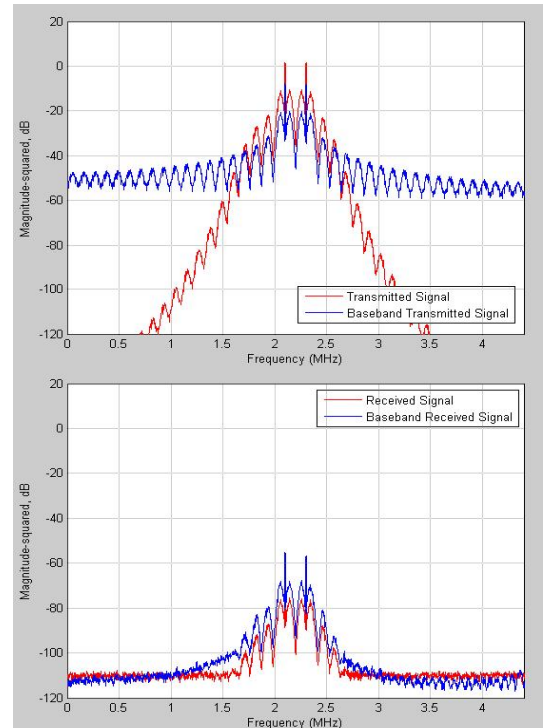

Fig. 4. The spectrum of transmission and reception signals.

Demodulation of the received signals is performed using envelope detection. At that time, path loss in free space is roughly 65 dB at a distance of 100 m at 433.92 MHz. The signals obtained by envelope detection are demodulated after being classified into '0' and '1' using a comparator. The waveform of demodulated signal is compared with the generated signal to check for errors.

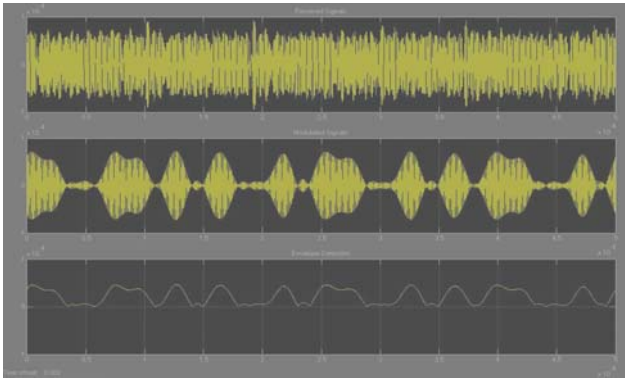

Fig. 5. The demodulation of the received signals

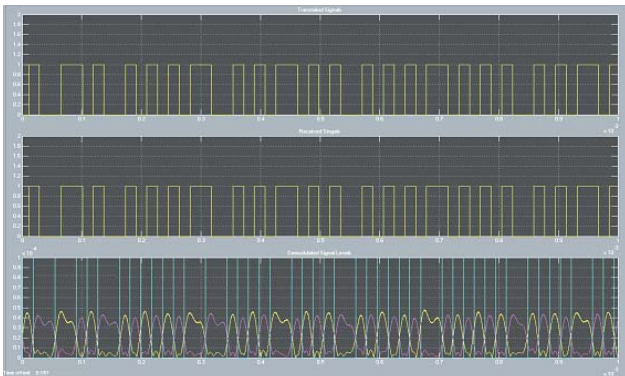

Fig. 6. The comparison between demodulated and received signals

4. Implementation and Evaluation

An emulator for evaluating active RFID consists of an RF module for the transmission of radio signals, an FPGA module for processing measured data, and a CPU module for mounting a management system to an evaluating device. A schematic view of the overall system is as shown in Figure 7.

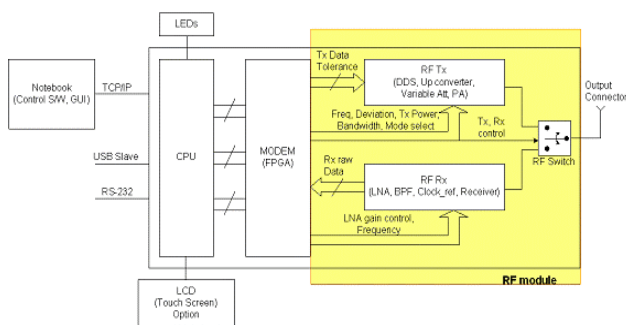

Fig. 7. A schematic view of the overall system

An RF module consists of a transmission block, a reception block, and a frequency-generating block. In addition, the module has an antenna, a digital section, a power supply section, and an interface. An FPGA module distinguishes the control command messages from the CPU, adjusts the RF module to the transmission/reception mode, and conducts data processing. Finally, a CPU module transmits all messages and data completely transmitted and received to a control computer.



Fig. 8. A view of the overall system

To evaluate the performances of the active RFID evaluating system designed in this study, the test conditions were set as shown in the following figure. In the evaluating system, transmission signals are received by a receiving antenna and measured using RF test equipment. By analyzing the measured signals, the performances of the produced evaluating system can be evaluated.

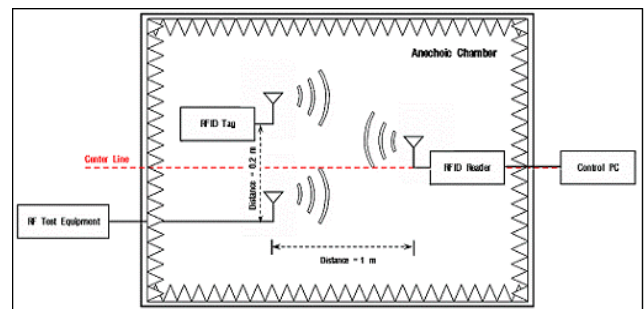
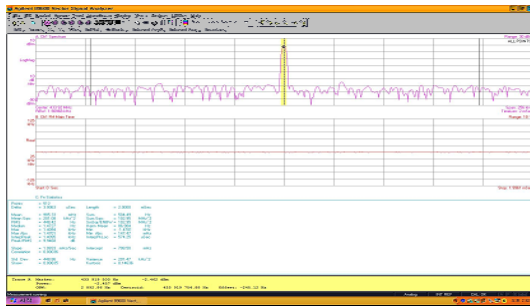
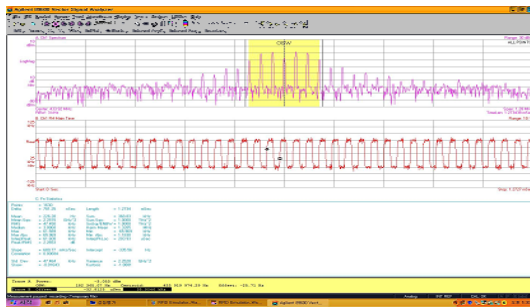

Fig. 9. The test conditions for evaluating the RFID emulator.

As a result of evaluating the performances of an emulator, transmission output can be checked by delivery of the carrier signal corresponding to 433.92 MHz, and a wakeup signal for waking up the tag can be generated. Furthermore, a preamble signal, meaning a preliminary signal before data for the signal decision between the reader and the tag of an active RFID, (which uses the same channel in transmitting and receiving signals), was generated so that it conforms to standards. The signal modulated by FSK was set so that it had a frequency shift of ± 50 kHz.



(a) carrier signal



(b) wakeup signal

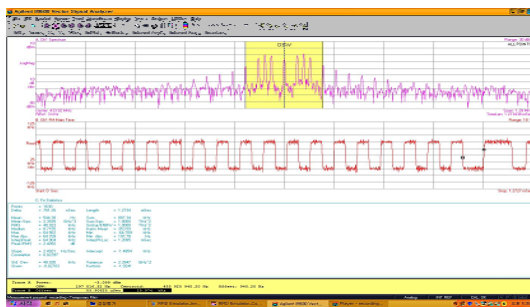

(c) preamble signal

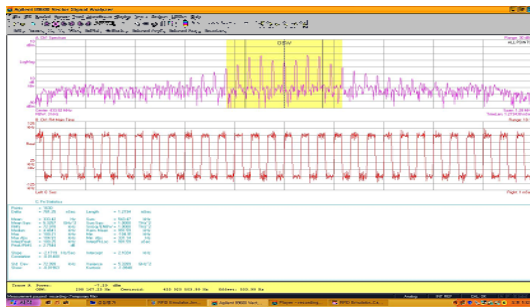

(d) modulated by FSK

Fig. 10. The result of evaluating the performances.

Lastly, a test for judging whether each of the active RFID tags for domestic and foreign products conformed to the ISO/IEC 18000-7 Air Interface Standard was also conducted. As a result of the test, the applicability of the tag as an emulator was observed.

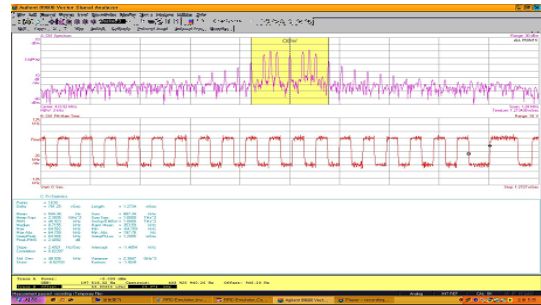

Fig. 11. The result of wakeup signal test.

5. Concluding Remarks

Recently, an active RFID system with a long identification distance and that is widely being applied to the areas of logistics and ports has received considerable attention. In addition, it is required for every container to be attached with a tag for simple domestic customs procedures in the USA. The system, then, has been helping fuel the development of technology for the active RFID system.

In this study, an emulator for standard conformance test on active RFID has been designed and substantiated. The developed evaluating device is a standard signal generator with reproducibility for standard conformance testing. It was designed so that the emulator would give commands or responses to the reader and tag to be tested, and that can check the malfunction of the reader and the tag using a standard signal. Further, some random functional changes, (i.e., transmission output, frequency shift, bit rate accuracy, etc.), have been made to the evaluating device to check for various errors and malfunctions raised in the testing sample for improvements to be made.

For further studies aimed at improving reproducibility and accuracy, improvements on the uncertainty of different measurement signals during the standard conformance test using an emulator should be developed.

References

- [1] Won-Ju Yoon, Sang-Hwa Chung, Hyun-Pil Kim, Seong-Joon Lee, "Implementation of a 433 MHz Active RFID System for U-Port," *Advanced Communication Technology*, vol. 1, pp. 106~109, 2007.
- [2] Cho H., Baek Y., "Design and implementation of an active RFID system platform," *SAINT Workshops*, 2006.
- [3] ISO/IEC 18000-7 "RFID for item management - Part 7 : Parameters for active air interface communications at 433 MHz," 2008.
- [4] ISO/IEC 18047-7 "RFID device conformance test methods - Part 7 : Test methods for active air interface communications at 433 MHz," 2005.