

Intergrated Circuit of CMOS DC-DC Converter with second-order active filter

Zhi-Yuan Cui¹, Chang-Yoon Yeom¹, Hua-Lan Piao¹, and Nam-Soo Kim¹

¹ Department of Semiconductor Engineering, School of Electrical and Electronics Engineering,
Chungbuk National University,

12 Gaeshin-dong, Heungduk-gu, Chungbuk 361-763, Korea

¹Tel: +82-43-261-2298, Fax: +82-43-274-9614

E-mail: czy@chungbuk.ac.kr, nsk@chungbuk.ac.kr

Abstract: The simple on-chip DC-DC converter is one using a single linear regulator to regulate over the desired frequency and voltage range. Active filter based on an op amp-RC resonator is proposed for a LC filter in DC-DC converter. Replacing a passive LP (low pass) filter to integrated circuit (IC) is important for the power electronics converter to achieve a simple and low-power on-chip DC-DC conversion scheme. We use an op amp-RC resonator for the second-order low-pass filter in the converter. The output ripple voltage is simulated by considering the simulation parameters in 0.35 μm CMOS process. Simulation result shows that the converter operates properly at 200 KHz switching frequency and the output ripple voltage is controlled within 57 mV at the input voltage of 5 V.

1. Structure of the proposed converter

Switching DC-DC converters are an indispensable component of traction of power control in several electronic applications. The converters can be used as switching-mode regulators to convert a dc voltage, normally unregulated, to a regulated dc output voltage. The regulation is normally achieved by PWM at a fixed frequency and the switching device is usually BJT, MOSFET, or IGBT. The DC-DC converters with various switching regulators are recently available [1-4] as integrated circuits. The designer selects the switching frequency by choosing the values of L and C of frequency oscillator. Although off-chip inductors and off-chip capacitors are needed in this system, efficiencies of 80% to 90% can easily achieved.

Recently, power electronics have been confronted with a strong demand for miniaturization and SoC application. To meet the demand, the off-chip power devices such as transformer, inductor, and capacitance should be substituted for semiconductor IC devices and fabricated together with other microelectronic circuits. Most on-chip DC-DC conversion systems have relied on buck converters with off-chip LC filters. The application of on-chip inductor replacement to switching converters and inverters may enhance the miniaturization and efficiency of power devices.

Fig.1 shows the proposed converter with the active low-pass filter, which is composed of 2 op-amp, 2 capacitors,

and 6 resistors. When the transistor switch is on for a high time duration in clock pulse of Fig.1(a), the switch conducts the inductor and capacitor current. This results in a positive voltage across the inductor. During the interval when the switch is off, because of the inductive energy storage, the inductor continues to flow. The output voltage fluctuations, which consist of a dc component and the harmonics at the switching frequency and its multiples, are very much diminished by using a LP filter. In order to get an on-chip inductor replacement in LP filter, the Antoniou inductance^[5] simulation circuit is applied. Over the years, many op amp-RC circuits have been proposed for simulating the operation of an inductor. Of these, the circuit of A. Antoniou is very tolerant to the nonideal properties of op amps, in particular their finite gain and bandwidth. The op amp-RC resonator can be used to generate circuit realization for the various second-order filter function. The equivalent inductance is obtained to be 250 mH, which is not a small value compared to the off-chip inductor. The duty ratio $D(t)$ of the converter is selected to be 0.5 and control the on-time and off-time duration of the power device to regulate the output voltage.

The electrical characteristic of OTA shown in Fig. 1 is summarized in table 1. The input bias current by current mirror is 163 μA . Bandwidth and gain are 130 MHz and 47.8 dB respectively. Table 2 is the combination of capacitance C and resistors R for 250 mH inductance. We applied a possible low capacitance for a limited cell area and an easy fabrication process.

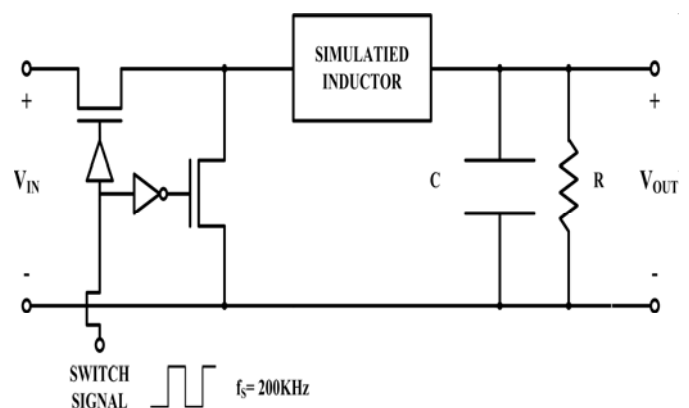

(a)

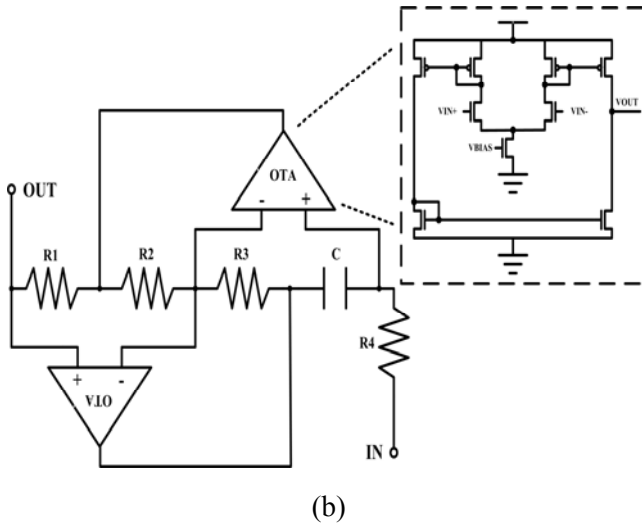

Fig. 1. (a) DC-DC (Buck) converter with simulated inductance.
 (b) Antoniou inductance simulation circuit and OTA circuit.

Table 1
 Electrical Performance of OTA

Electrical characteristics of OTA	
DC Gain (V _{out} /V _{in})	47.8 dB
Input Resistance (R _i)	∞
Output Resistance (R _o)	1.78 KΩ
Bandwidth	130 MHz
CMRR	83.9 dB
Input bias current	163 μA
Output Voltage	0V ~ 5V

Table 2
 R and C variencies for 250mH Antoniou inductance

Antoniou Inductance 250mH			
C	125nF	25nF	25nF
R ₁	1K	10K	20K
R ₂	5K	5K	10K
R ₃	10K	5K	5K
R ₄	1K	1K	1K

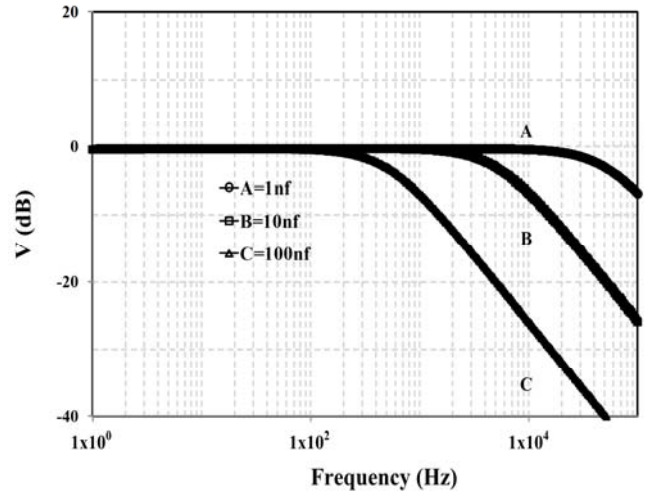

Fig. 2. Characteristics of low pass filter with variation of the capacitance in LP filter.

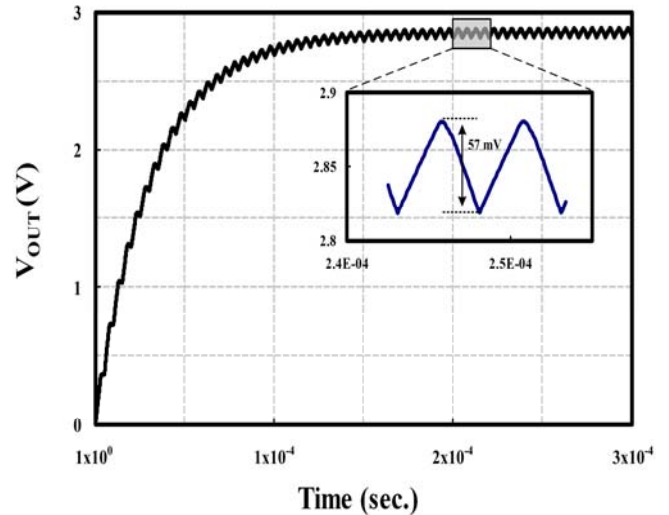

Fig. 3. The output voltage of 2.85V and output ripple voltage of 57mV at switching frequency of 200 KHz.

2. Result

IC implementation of DC-DC converter has done with a standard 0.35 μm CMOS process. The converter is supplied with an input voltage of 5.0 V and switching frequency of 200 KHz. In IC implementation of the Antoniou inductor, two symmetric resistors R₂ and R₃ are optimized for a proper inductance and miniaturization rather than capacitance C. The simulation result of low-pass filter characteristics is shown in Fig.2. The corner frequency f_c which depends on the simulated inductance and conductance is to minimize the output ripple voltage and be much lower than the switching frequency. The corner frequency f_c in our experiment is controlled within 10 KHz with 10 nF on-chip capacitor. The output voltage and the output ripple voltages are shown in Fig.3 for the case of

duty ratio 0.5. At switching frequency of 200 KHz, The output voltage of 2.85V and output ripple voltage of 57mV are obtained. With increase of inductance L, a lower ripple voltage is expected.

Fig. 4 shows the waveforms of the inductor current. When the clock signal is in high, the buffer and inverter switches operate reversely each other. The buffer switch conducts the inductor current. When the clock signal is in low, because of the inductive energy storage, the inductor current continues to flow. The current now flows through the inverter switch. Since in steady-state operation the waveform must repeat from one time period to the next, the integral of the inductor voltage over one time period is expected to be zero. The inductor current in this experiment shows to have a limitation. It seems to come from a small DC output voltage range in OTA in the Antoniou inductor. In this converter, the output voltage varies linearly with the duty ratio of the switch for a given input voltage. It does not depend on any other circuit parameter. Recognizing that the average voltage across the inductor in steady-state operation is zero, our result in Fig. 4 requires more work to do.

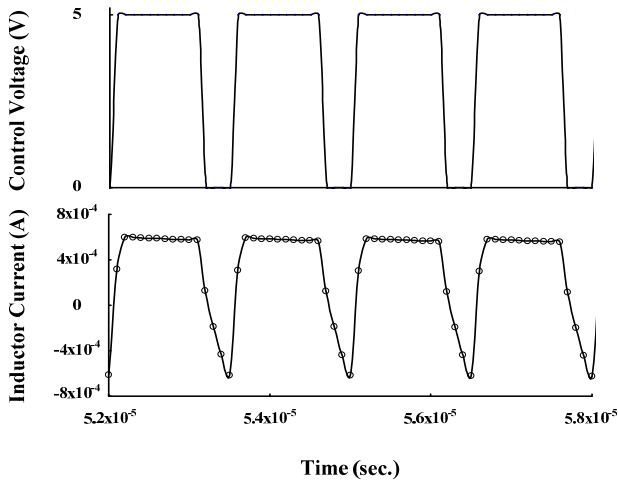

Fig. 4. Inductor current with on-off switching time.

Fig.5 is the transient response of output voltage with variation of capacitance in the LP filter. Using this filter, the output voltage overshoots are shown in Fig.6. In Fig.5, the recovery time is in the order of 400μs for capacitance C = 100nF and 2μs for C = 1nF, which produces the expected slow transient response for a high capacitance LP filter. The ripple voltage in Fig. 6 depends on a corner frequency f_c of the low pass filter, which is inversely proportional to $LC^{0.5}$. We note the voltage ripple is minimized by selecting a corner frequency f_c of the filter such that $f_c \ll f_s$, where f_s is the switching frequency. For capacitance C = 10nF, the percentage ripple in the output voltage is controlled to be less than 2% with 250 mH inductance in the LP filter,

where the output voltage and output ripple voltage are about 2.85V and 57 mV respectively.

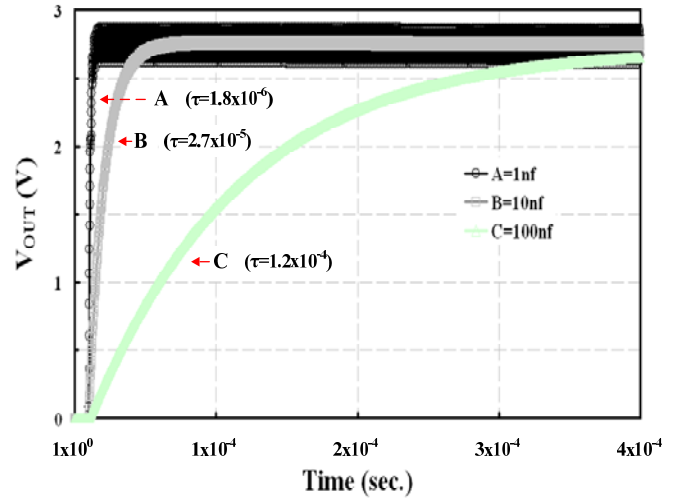

Fig. 5. Transient response of output voltage with variation of capacitance in the LP filter

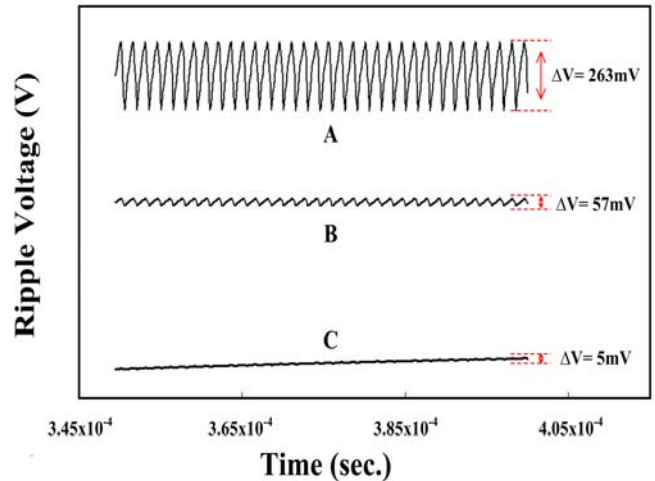

Fig. 6. Output ripple voltages for the three different capacitance in the LP filter.

3. Conclusion

We simulated an integrated 5V DC-DC buck converter implemented in a 0.35 μm CMOS process with on-chip inductor. Using an Antoniou inductor and operating at the frequency of 200 KHz, we obtain the output ripple voltage is controlled to be less than 2% with 250 mH inductance in the LP filter. Although our work of the Antoniou inductor requires more study about an operating range of DC characteristics in OTA, the on-chip inductor in DC-DC converter may improve the miniaturization and efficiency of power devices.

References

- [1] Benjamin J. Patella, Aleksandar Prodic, Art Zirger, and Dragan Maksimovic, "High frequency digital PWM controller IC for DC-DC converters," *IEEE Trans. Power Electronics*, vol. 18, no. 1, pp. 438-446, 2003.
- [2] George Patounakis, Yee William Li, and Kenneth L. Shepard, "A fully integrated on-chip DC-DC conversion and power management system," *IEEE J. Solid-State Circuits*, vol. 39, no. 3, pp. 443-451, 2004.
- [3] Cheung Fai Lee and Philip K.T. Mok, "A monolithic current-mode CMOS DC-DC converter with on-chip current sensing technique," *IEEE J. Solid-State Circuits*, vol. 39, no. 1, pp. 3-14, 2004.
- [4] H. Pooya Forghani-zadeh and Gabriel A. Rincon-Mora, "An accurate, continuous, and lossless self-learning CMOS current-sensing scheme for inductor-based DC-DC converter," *IEEE J. Solid-State Circuits*, vol. 42, no. 3, pp. 665-679, 2007.
- [5] Adel S. Sedra and Kenneth C. Smith, "Microelectronics circuits, 5th ed." Oxford University Press, pp. 1112-1114, 2004.