

Comparison of Non-Foster Circuit Augmentations of a Near-Field Resonant Parasitic Antenna

Jeffrey S. Roberts and Richard W. Ziolkowski

Department of Electrical and Computer Engineering, University of Arizona,
1230 E. Speedway Blvd., Tucson, AZ, 85721-0104 USA

Abstract – The impedance bandwidth of a metamaterial-inspired, electrically small Egyptian Axe Dipole (EAD) antenna is enhanced by augmenting it internally with a non-Foster circuit. Several different non-Foster implementations have been studied, including a variety of symmetric and asymmetric 2-BJT and 4-BJT based Linvill designs and operational amplifier-based design. The circuit and antenna performance characteristics have been obtained through ANSYS HFSS and Agilent ADS co-simulations. The design goal is a 15% or greater impedance bandwidth from an electrically small, stable, component tolerant, 300 MHz center frequency design.

Index Terms — Electrically small antennas, impedance bandwidth, non-Foster circuits, metamaterials.

I. INTRODUCTION

Electrically small antennas (ESAs) are a topic of great research interest because of their utility for a wide variety of wireless applications. However, because of their compact size, ESAs are generally not efficient radiators and they have narrow bandwidths. There have been many efforts to overcome the conflicting performance characteristics of ESAs, including their efficiencies, bandwidths, and directivities, using a variety of meta-structures, e.g., [1].

To overcome the impedance bandwidth fundamental bounds set by positive definite energy constraints associated with passive systems [2]-[4], we have introduced active, non-Foster elements into the near-field resonant parasitic elements of several electrically small, near-field resonant parasitic (NFRP) antennas [5]-[9]. This internal non-Foster element approach enables nearly complete impedance matching to a 50 Ω source without any external matching network over an extended, large instantaneous frequency range. It has been confirmed independently [10].

The active non-Foster elements in these designs were realized with negative impedance convertor (NICs) circuits. Many of these NIC-augmented, NFRP ESAs have been simulated, fabricated and tested. Comparisons of the simulation and experiment results have been very favorable. NIC-based designs have also led to enhanced directivity bandwidths [11] and to an ESA design which simultaneously exhibits a high overall efficiency, a high directivity, a large front-to-back-ratio and a large instantaneous impedance bandwidth [12].

Despite these successful implementations, the sensitivity of the performance of the NIC circuits to component

tolerances and stability issues severely complicates testing and continues to frustrate their acceptance for general use. To explore these realization issues further, we have been studying several classes of NIC circuits. These include 2-BJT circuits based on symmetric and asymmetric layouts of the original Linvill NIC [13]; 4-BJT designs such as those considered, for example, in [14]; and operational amplifier (OpAmp) designs such as those considered, for instance, in [15]. Our investigations are aimed at achieving an ESA, based on the NIC-augmented Egyptian Axe Dipole (EAD) design [9], whose center frequency is 300 MHz and has at least a 15% fractional bandwidth (FBW).

II. EAD FREQUENCY AGILE DESIGN

The ANSYS HFSS 2014 model of the electrically small, planar, EAD antenna considered in this non-Foster study is shown in Fig. 1. The NFRP element of this metamaterial-inspired antenna is a curved version of the “I” metamaterial unit cell element. The driven element is a simple dipole antenna. The 300 MHz design shown in Fig. 1 is based on 0.5-oz (0.017 μm thick copper), 31-mil (0.7874 mm) thick Rogers Duroid™ 5880 substrate ($\epsilon_r = 2.2$, $\mu_r = 1.0$, loss tangent = 0.0009). An inductor is integrated into the NFRP element at its center. The simulated $|S_{11}|$ values are shown in Fig. 2 for inductor values varying from 20 to 39 nH. A good matched design is assumed to have a $|S_{11}|$ value of -10 dB or smaller. At the center frequency, 300 MHz, the antenna has a FBW ~ 1.4 %. The frequency agile 10dB bandwidth shown in Fig. 2 for this passive antenna is about 40 MHz, giving a FBW $\sim 13.33\%$, i.e., nearly a factor of 10 enhancement.

The resonance frequency (where $|S_{11}|$ is a minimum) for these inductor values is plotted in Fig. 3. The corresponding reactance curve has the same negative slope behavior, which is a non-Foster behavior, i.e., $\partial_{\omega}(\omega L) < 0$. Consequently, the NIC must reproduce this curve to achieve the corresponding instantaneous impedance bandwidth.

III. NON-FOSTER CIRCUITS

The HFSS sp2 file resulting from simulating the EAD response with a port substituted for the inductor was imported into Agilent ADS. The various NIC designs were tested with this ADS antenna model. Our preliminary results have indicated that the symmetric 2-BJT circuit design, such

as the one shown in Fig. 4, is actually the most robust. It produces a FBW $\sim 17\%$ for a $ka < 0.5$ EAD antenna. While the OpAmp NIC-based designs have achieved almost a 30% FBW, they have proven to be very sensitive to the component values. A variety of NIC design details and the corresponding EAD ESA simulation results will be shared in our presentation.

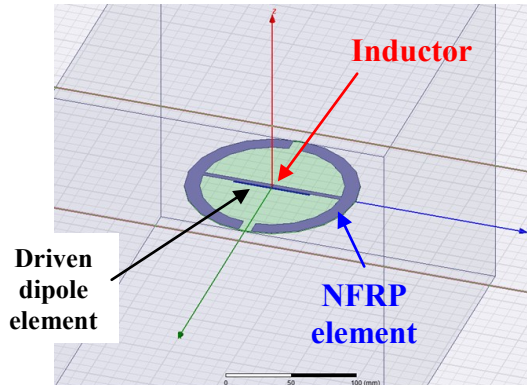

Fig. 1 ANSYS HFSS EAD model. The NFRP element contains an inductor to allow for frequency agility.

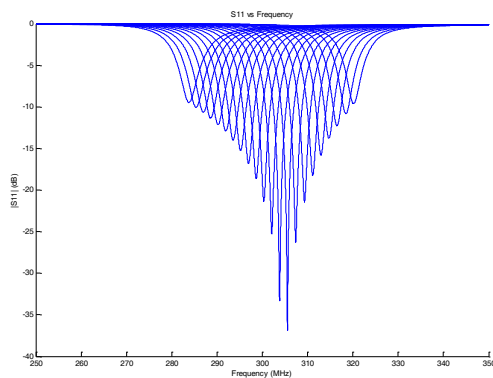

Fig. 2 $|S_{11}|$ values showing matching as the inductor value is varied from 20 to 39 nH.

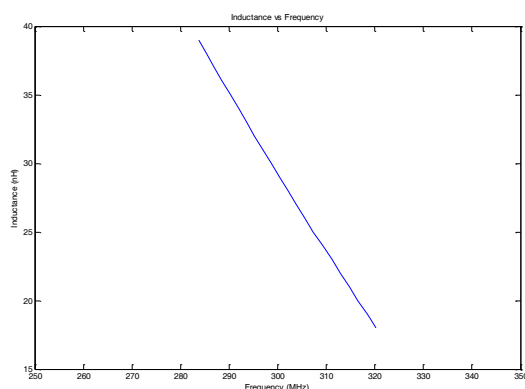

Fig. 3 Inductor values versus resonance frequency. The non-Foster behavior (negative slope) required for the desired 15% instantaneous impedance bandwidth is clearly observed.

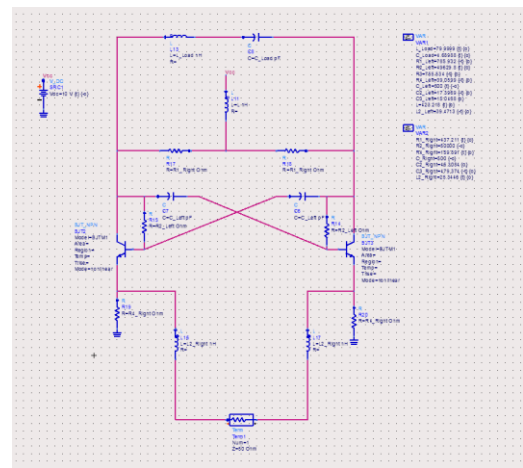

Fig. 4 Example of a robust, symmetric 2-BJT NIC design.

REFERENCES

- [1] R. W. Ziolkowski, P. Jin, and C.-C. Lin, "Metamaterial-inspired engineering of antennas," *Proc. IEEE*, vol. 99, pp. 1720-1731, Oct. 2011.
- [2] L. J. Chu, "Physical limitations of omni-directional antennas," *J. Appl. Phys.*, vol. 19, pp. 1163-1175, Dec 1948.
- [3] H. L. Thal, "New radiation Q limits for spherical wire antennas," *IEEE Trans. Antennas Propag.*, vol. 54, pp. 2757-2763, Oct. 2006.
- [4] M. Gustafsson, C. Sohl and G. Kristensson, "Illustrations of new physical bounds on linearly polarized antennas," *IEEE Trans. Antennas Propag.*, vol. 57, pp. 1319-1327, May 2009.
- [5] P. Jin and R. W. Ziolkowski, "Broadband, efficient, electrically small metamaterial-inspired antennas facilitated by active near-field resonant parasitic elements," *IEEE Trans. Antennas Propag.*, vol. 58, pp. 318-327, Feb. 2010.
- [6] N. Zhu and R. W. Ziolkowski, "Active metamaterial-inspired broad bandwidth, efficient, electrically small antennas," *IEEE Antennas Wireless Propag. Lett.*, vol. 10, pp. 1582-1585, 2011.
- [7] N. Zhu and R. W. Ziolkowski, "Broad bandwidth, electrically small antenna augmented with an internal non-Foster element," *IEEE Antennas Wireless Propag. Lett.*, vol. 11, pp. 1116-1120, 2012..
- [8] N. Zhu and R. W. Ziolkowski, "Design and measurements of an electrically small, broad bandwidth, non-Foster circuit-augmented protractor antenna," *Appl. Phys. Lett.*, vol. 101, 024107, Jul. 2012.
- [9] N. Zhu and R. W. Ziolkowski, "Broad bandwidth, electrically small, non-Foster element-augmented antenna designs, analyses, and measurements," *IEICE Transactions on Communications*, vol. E96-B, no.10, pp. 2399-2409, Oct. 2013.
- [10] H. Mirzaei and G. V. Eleftheriades, "A resonant printed monopole antenna with an embedded non-Foster matching network," *IEEE Trans. Antennas Propag.*, vol. 61, pp. 5363-5371, Nov. 2013.
- [11] M.-C. Tang, N. Zhu and R. W. Ziolkowski, "Augmenting a modified Egyptian axe dipole antenna with non-Foster elements to enlarge its directivity bandwidth," *IEEE Antennas Wireless Propag. Lett.*, vol. 12, pp. 421-424, 2013.
- [12] R. W. Ziolkowski, M.-C. Tang and N. Zhu, "An efficient, broad bandwidth, high directivity, electrically small antenna," *Microw. Opt. Technol. Lett.*, vol. 55, no. 6, pp. 1430-1434, June 2013.
- [13] J. G. Linvill, "Transistor negative-impedance converters," *Proc. IRE*, vol. 41, pp. 725-729, June 1953.
- [14] C. R. White, J. S. Colburn and R. G. Nagele, "A non-Foster VHF monopole antenna," *IEEE Antennas Wireless Propag. Lett.*, vol. 21, pp. 584-587, 2012.
- [15] Y. Shen and T.-H. Chio, "Limitation of negative impedance converter using operational amplifier for matching electrically small antenna," *Proc. of the 2013 IEEE Antennas and Propagation Society International Symposium*, Orlando, FL, July 2013, pp. 1962-1963.