

Design of the E-field Probe with Variable Resistors

Sang il Kwak^{1,2}, Jong Hwa Kwon¹, and Young Joong Yoon²

¹ Radio Technology Research Department, ETRI, 218 Gajeong-ro, Yuseong-gu, Daejeon, KOREA

²Department of Electrical and Electronics Engineering, Yonsei University, 50 Yonsei-ro, Seodaemun-gu, Seoul, KOREA

Abstract – This paper shows a development of an E-field probe in a personal exposure measurement meter for occupational exposure. To evaluate an exposed E-field near the human body, the personal exposure measurement meter is used. This device composes of the E-field probe and a readout device. The probe is consist of three orthogonal small dipoles with diode and lossy transmission lines with chip resistors. To improve the probe sensitivity, the use of various chip resistors has been proposed in this paper. The bandwidth of the designed E-field probe is from 800 MHz to 2.5 GHz for mobile communication bands. The fabricated E-field probe with variable resistors and the characteristics of the probe such as linearity and isotropic deviation are presented in this paper.

Index Terms — probe, various resistors, sensitivity, health effect.

I. INTRODUCTION

Electric devices are widely used in human life. As use of the devices working proximity to the human body is increased, the body worn technology, power reduction techniques and the health risk from electromagnetic wave is considered to be an import subject [1]-[2]. To evaluate the health effect from the electromagnetic field, the measurement of an exposed E or H field or SAR (Specific Absorption Rate) and comparison of human exposure guideline is needed. The E or H field and SAR value must not over the limit [3]. To measure the exposed E-field, an E-field probe is used.

A personal exposure measurement meter is consist of a probe with lossy transmission line and a readout device. The E-field probe is made up of three small dipoles, a diode for converting the detected incident wave into a DC voltage and a resistive transmission line. The small dipoles are arranged perpendicularly for good isotropy deviation. The converted DC voltage is transmitted over the lossy transmission line to the readout device. Since it does not receives a signal transmitted from the outside and act as a low pass filter, the transmission line has a high resistance value. To obtain high resistance value easily, chip resistors, NiCr and carbon materials are used [4]. The readout device is consist of an amplifier, signal process components, display components and a battery.

In this paper, the E-field probe in the personal exposure measurement meter is designed. To improve the probe performance, various chip resistors are applied. The bandwidth of the proposed probe is 800 MHz to 2.5 GHz for communication bands. The fabricated E-field probe and characteristics such as linearity and isotropic deviation will be presented in this paper.

II. DESIGN OF THE PROBE

The E-field probe for communication bands has already been reported in [5]. To improve the performance such as sensitivity and dynamic range, various values of chip resistors are used as shown in figure 1. Table 1 shows parameter values of the designed probe with transmission line. The condition of small dipole at 2.5 GHz ($kh \leq 0.3$, $k = \text{wavelength}$, $h = \text{dipole length}$) is applied, the total size of the dipole is 5 mm x 3 mm. A HSCH-5330 schottky diode is used. The spatial angle of the three dipoles is 54.74° . To obtain highly resistive property, chip resistors with variable values are inserted in the transmission line as shown in figure 1. Because of the impedance matching between transmission line and readout device, the total resistance value per one line is 220 k Ω and it is implemented by ten resistors have different values. The length of the probe is 62.7 mm and total length is 71.4 mm with the support materials. The size of a readout device is 60 mm x 30 mm x 90 mm and covered with the metal.

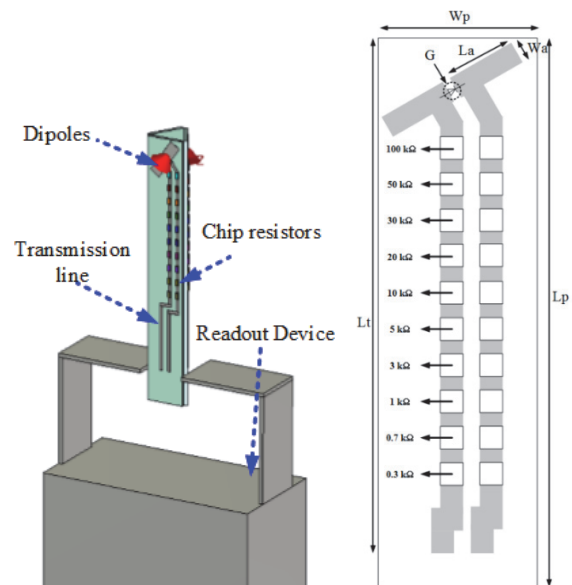

Fig. 1. Layout of the proposed probe

TABLE I
DESIGN PARAMETER

Wa	Wp	La	Lp	Lt	G
3 mm	10 mm	5 mm	71.4 mm	62.7 mm	0.5 mm

III. RESULTS

A. Measurement set-up

Figure 2 shows measurement set-up. The designed probe is measured in a GTEM cell which can create uniform E-fields at specific location. The GTEM cell, a signal generator, an attenuator and a power amplifier is used for the measurement.

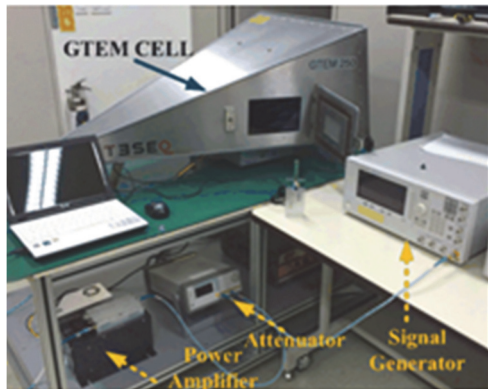

Fig. 2. Measurement set-up

B. Results

To measure the linearity of the probe, the input power is changed linearly using the signal generator and the attenuator. As input power is increased, the probe receives the transmitted signal in the GTEM cell and the detected signal is transformed into a voltage. The transformed voltage value is recorded in the readout device and compared to the input power or the E-field. Figure 3 shows measurement result of linearity characteristic of the probe. As the input power increases, the output voltage value of the probe also increases linearly. Also, the sensitivity and dynamic range of the proposed probe is improved up to 10 dB than the previous works [5].

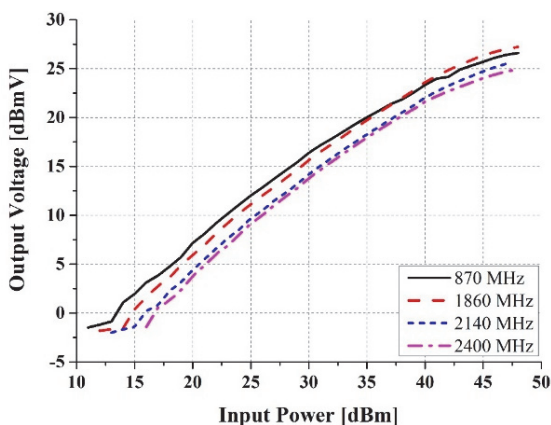

Fig. 3. Measurement results: Linearity

The simulated pattern of the probe is shown in figure 4. The isotropic deviation is a parameter that expresses the accuracy in measuring field values irrespective of the probe's orientation [6]. The simulated isotropic deviation is ± 0.135 dB,

± 0.79 dB, ± 0.6 dB, ± 0.265 dB at 870 MHz, 1.86 GHz, 2 GHz, 2.4 GHz, respectively. The pattern of the probe is measured also in GTEM cell. As the input power is fixed, the designed probe is rotated in the GTEM cell and measured the received voltage. The measurement result will be shown at the conference.

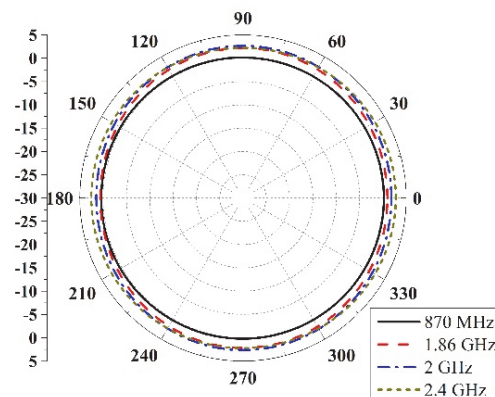

Fig. 4. Simulation results: Pattern of the probe

IV. CONCLUSION

In this paper, the E-field probe in the personal exposure measurement meter is designed. To improve the probe performance, various chip resistors are applied. The size of the dipoles are 5 mm x 3 mm. The total length of the probe is 71.4 including the supporting materials. The bandwidth of the probe is 800 MHz to 2.5 GHz for communication bands. The fabricated E-field probe characteristics such as linearity and isotropic deviation are presented in this paper.

ACKNOWLEDGMENT

This work was supported by ICT R&D program of MSIP/IITP. [13-911-01-105, A Study on Health Effects and protection of EMF]

REFERENCES

- [1] W.Gao, B. Jiao, G. Yang, W. Hu and J. Liu, "Transmission Power Control for IEEE 802.15.6 Body Area Networks," *ETRI Journal*, Vol.36, No.2, pp.313-316, Apr. 2014.
- [2] Sang il Kwak, D.-U. Sim and J. H. Kwon, "Design of optimized multilayer PIFA with the EBG structure for SAR reduction in mobile applications," *IEEE Trans. Electromagnetic Compatibility*, Vol.53, No.2, May 2011.
- [3] "Guidelines on limits of exposure to radio frequency electromagnetic fields in the frequency range from 100 kHz to 300 GHz," *Health Phys.*, Vol.54, No.1, pp.115-123, 1988, International Non-Ionizing Radiation Committee of the International Radiation protection Association.
- [4] H.I. Bassen and G.S. Smith, "Electric field probes-A review," *IEEE Trans. Antenna and Propg.*, Vol.31, pp.710-718, Sep. 1983.
- [5] Sang il Kwak, J.H. Kwon and Y.J. Yoon, "Design of the E-field probe for Mobile Communication bands in the Personal Exposure meter," *ISCE2014*, pp.362-363, June 2014.
- [6] http://en.wikipedia.org/wiki/EMF_measurement