

# Frequency Reconfigurable Antenna for Two Ways Radio at VHF Band

Dau-Chyrh Chang<sup>1</sup>, Chia-Ping Huang<sup>1</sup>, Chang-Hsuan Kao<sup>1</sup>, Chih-Hung Lee<sup>2,3</sup>

Oriental Institute of Technology, <sup>2</sup>Yuan Ze University

CRC, OIT<sup>3</sup>Electronics, Testing Center, Taiwan

New Taipei city, Taiwan

dcchang@oit.edu.tw, billytom78119@yahoo.com.tw, tw642.kevin@gmail.com

**Abstract** - Frequency reconfigurable antenna for VHF two ways radio is designed. The frequency band for the VHF antenna is from 135 MHz to 174 MHz will be designed in this paper. The meander line antenna and the frequency reconfigurable circuits are printed on the FR4 substrate with size 20 mm x 174 mm x 0.8 mm. The antenna is mounted on the structure with size 60 mm x 140 mm x 40 mm. There are three parallel frequency reconfigurable circuits as part of the antenna. Each circuit includes PIN diode series with lump inductor. By using the ADS tool to design the proper inductor values for the desired frequency, three reconfigurable bands to cover 135 MHz to 174 MHz can be achieved. The results of simulation and measurement are very close.

**Keywords**— reconfigurable antenna; PIN diode; two way radio

## I. INTRODUCTION

For the wireless communication system, the received signal will be faded due to the Doppler frequency shift, multipath effect, and blockage, etc.,. These fading will degrade the communication performance, such as higher bit error rate, or lower channel capacity. Although the SDR (software defined radio) may adaptive the characteristics of communication subsystems, such as frequency of transmitter, receiver, and digital signal processor, to the environment, it is not easy to change the antenna impedance bandwidth in VHF band. For the poor antenna impedance, matching, the antenna mismatch efficiency will be lower. For lower mismatch efficiency the overall antenna efficiency will be lower too. The BER (bit error rate) of data communication will increase or data throughput will decrease due to lower antenna efficiency. How to improve the antenna efficiency is an important job in wireless communication system.

## II. ANTENNA DESIGN AND ITS PERFORMANCE

The VHF two ways radio is working in the band 135 MHz~174 MHz. The antenna bandwidth is about 25%. Usually the antenna is a circular helix monopole antenna. The impedance bandwidth of the helix monopole antenna is narrow. In this paper impedance reconfigurable antenna will be designed for this band. In order to have optimum reconfigurable circuit, the whole band will divide into three

sub-bands. They are 135 MHz~145 MHz, 145 MHz~160 MHz, and 160 MHz~174 MHz. By programming control the PIN diode switches, the desired band can be reconfigurable.

Fig.1 shows the geometry of the meander line antenna mounted on the two ways radio. The antenna is printed on FR4 substrate with size 20 mm in width by 174 mm in length by 0.8 mm in thickness. The detail size of antenna and two ways radio is tabulated in table 1. The detail dimension of prototype is tabulated in Table 1.1.

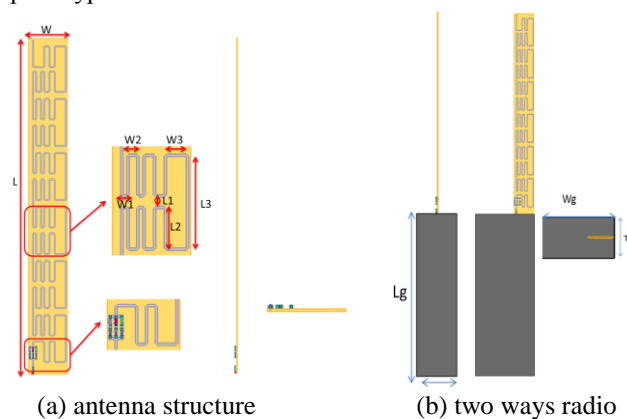

Fig.1 Antenna and two ways radio

Table 1.1 Antenna structure

Antenna	Unit:(mm)
L	174
W	20
Thickness	0.8
W1	2.25
W2	3.4
W3	6.5
L1	2.3
L2	11.35
L3	25
Ground	Unit:(mm)
Wg	60
Lg	140
Thickness	40

The meander line antenna acts as a resonant LC circuit. The vertical elements act as the inductor, horizontal elements act as capacitor. The lumped inductance and capacitance of meander line antenna are modeled and optimized using GEMS and ADS simulator. The resonant frequency of

meander line antennas can be predicted using an equivalent inductor circuit model in the simulation procedure. By using the equation (1), proper resonance frequency can be estimated for the value of inductance. Fig.2 shows the equipment circuits of PIN diode switch for short circuit and open circuit. The equivalent circuit for three impedance matching network is shown in Fig.3.

$$\bar{X}_L = j\omega L \quad (1)$$

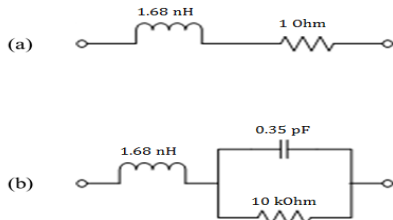

Fig.2 PIN diodes (a) short circuit (b) open circuit

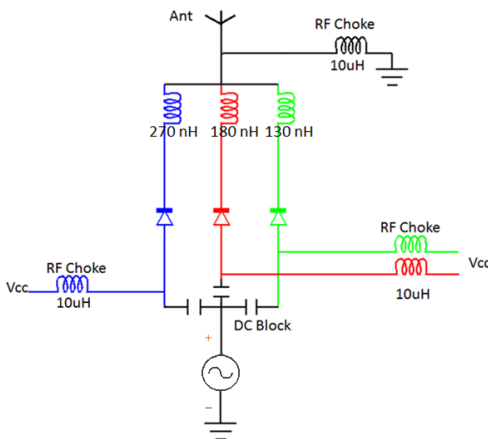

Fig.3 Equivalent circuit switching

At the VHF desired band (135MHz~174MHz), by using the ADS matching tool, the calculated series inductances are 270nH, 180nH, and 130nH respectively. The results of simulated and measured return loss at 140MHz , 155 MHz, and 166 MHz are shown in Figs. 4-6.

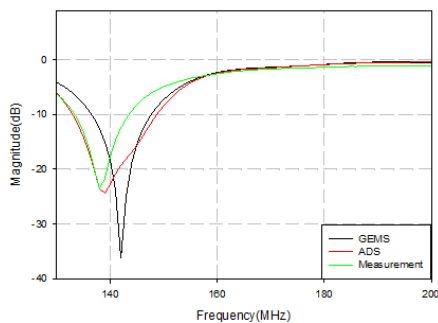

Fig.4 Result of simulated and measured at 140 MHz

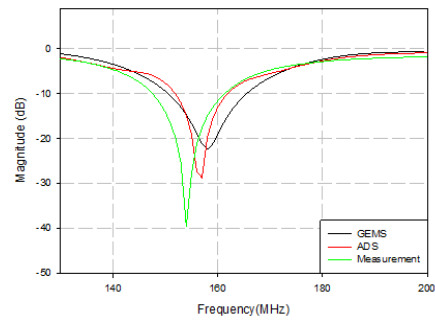

Fig.5 Result of simulated and measured at 155 MHz

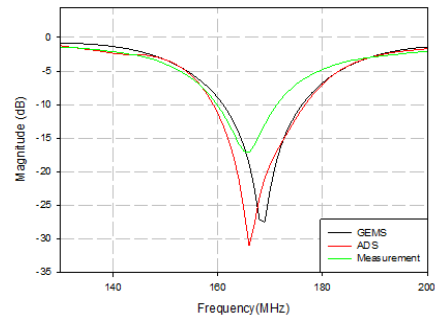

Fig.6 Result of simulated and measured at 166 MHz

### III. CONCLUSION

The frequency reconfigurable meander line antenna for VHF two ways radio is designed. The resonance frequencies of antenna are at 140 MHz, 155 MHz, and 166 MHz for series lump inductor 270 nH, 180 nH, and 130 nH respectively. By proper control the PIN diode switches, the frequency reconfigurable antenna will cover the band 135 MHz~174 MHz. The detail of this antenna which includes efficiency, radiation pattern and design procedure will be discussed during the presentation.

### REFERENCES

- [1] GEMS, 3-D High Performance parallel EM simulation Software, [www.2comu.com](http://www.2comu.com).
- [2] Dau-Chyrh Chang , Fong-Yi Lin , "Study of Frequency Reconfigurable Antenna on VHF Two Ways Radio", PIERS 2013.
- [3] Dau-Chyrh Chang , Hsin-Chi Li, "Study of Novel Reconfigurable Antenna for Radiation Diversity", IEEE iWEM 2013
- [4] H. Jasik, Ed., Antenna Engineering Handbook. New York: Mcradius Graw-Hill, 1961, ch. 22.
- [5] Jalil Rashed and Chen-To Tai, "A New Class of Resonant Antennas," IEEE TRANSACTIONS ON ANTENNAS AND PROPAGATION, VOL. 39, NO. 9, SEPTEMBER 1991.
- [6] H.A. Wheeler, "Small Antenna," IEEE Transactions on Antenna and Propagation, vol. ap-23, no. 4, pp. 462-469, Jul. 1975.
- [7] W.H. Weedon, W.J. Payne, and G.M. Rebeiz, "MEMS-switched reconfigurable antennas," in Proc. IEEE AP-S Int. Symp. Antennas and Propagation, 2001, pp.654-657