

FDMA System with STTC Coding and CPM Signals

Piotr Remlein

Chair of Wireless Communications
Poznan University of Technology
Poznan, Poland
e-mail: remlein@et.put.poznan.pl

Abstract— The paper considers a wireless transmission system in a multiple-user environment. It involves a combination of Space-Time Trellis Coding (STTC) with Continuous-Phase Modulations (CPM) for multiple-antenna transmission (MIMO) in an uplink connection using the Frequency Division Multiple Access (FDMA) method. For a more efficient available band utilization, the distances between individual system user carriers are small. Such solution causes the deterioration of transmission quality due to the occurrence of Inter-Channel Interference (ICI). In order to reduce the bit error rate (BER), a combination of CPM and STTC has been used, along with a Minimum Mean Square Error (MMSE) MIMO detector and a low-complexity iterative algorithm for Inter-Carrier Interference (ICI) cancellation on the receiver side. BER results obtained in computer simulations are presented for proposed system.

Keywords— *continuous phase modulation; space time coding; multiuser transmission*

I. INTRODUCTION

The increasing number of users of wireless communication systems forces the application of signals that efficiently make use of the available frequency bandwidth. The group of digital modulations producing a high spectral efficiency (SE) includes signals with CPM (Continuous Phase Modulation) [1]. In addition to good spectral properties, CPM signals are characterized by a constant envelope, so they can be generated by cheap, efficient, nonlinear amplifiers. CPM signals have been applied in GSM telephony, Bluetooth system, and satellite connections [2, 3, 4].

FDMA (Frequency Division Multiple Access) [2] is one of the techniques of band sharing between many users. In an FDMA system, each user is assigned one or more frequency channels, so that a few users can simultaneously transmit at the assigned frequencies. A drawback of FDMA is the necessity of using precise steep-slope filters both on the transmitter and receiver sides.

The filters on the transmitter side determine the spectrum of the transmitted signal, so as to make it fit the band of the assigned channel, whereas the filters on the receiver side separate the channels and limit inter-channel interference (ICI).

In order to increase the reliability and bit rate of telecommunication systems, the multi-antenna MIMO technique (Multiple Input Multiple Output) is used more and more often [5]. The technique involves multiple antennas on the transmitter and receiver sides. The advantages of the

multiple-antenna solution consist in the benefits of diversification, collective reception and multiplexing [2, 5]. Employing the MIMO technique in telecommunication systems allows the use of Space-Time Codes (STC), improving transmission quality [6]. The group of STC codes includes Space-Time Trellis Codes (STTC) and Space-Time Block Codes (STBC). As compared to STBC codes, STTC codes introduce – in addition to the benefit of diversification – also the benefit of coding, but the decoding procedure in systems with STTC is more complex than STBC decoding [6].

Among the first significant works on the application of CPM signals in multiple-antenna systems were [9], [10] and [11] devoted to the combination of Constant-Phase Modulation and Space-Time Coding. In [9] and [11], the authors presented the principles of structuring STC codes for CPM for a transmission via a quasi-statistical channel with fading, and for a small number of streams. In [10], they proposed a soft-decision algorithm for STC-CPM signal demodulation. At the transmission end, they used an interlaced system and an external convolutional encoder. The rules developed in [11] have been extended in [12] for the case of STC structure for CPM and a transmission via a channel with fast fading. [13] and [14] studied CPM signals encoded using the so-called orthogonal space-time codes based on Alamouti's solution for linear modulations [15], i.e., on STBC (space-time block coding). This coding technique requires a simple receiver structure, but the complexity lies in obtaining orthogonal STC-CPM signals to ensure phase continuity of the encoded CPM signals, which consequently limits the practical use of this solution. This disadvantage is absent from the new class of orthogonal STC codes for CPM proposed in [16] and [17]. They are characterized by a low bit error rate attainable at a simultaneously low receiver complexity. Neither of the above solutions for MIMO transmission concerned multiuser CPM systems.

The literature has already discussed the aspects of increasing the spectral efficiency of systems employing CPM and FDMA (e.g., in [7]), but STTC coding in multiuser scenario has not been taken into consideration. This paper presents the operation of an FDMA system using CPM signals combined with STTC. The system performs transmission in an uplink connection. Using computer simulation, BER curves were determined in the function of E_b/N_0 for selected systems with STTC CPM signals.

The paper is organized as follows. Section 2 presents a brief description of CPM signals. Section 3 describes STTC coding. Section 4 presents the considered system. Section 5 provides the obtained simulation results. The paper is summarized and concluded in the final, sixth Section.

II. CPM SIGNALS

The general equation describing CPM signals may be presented as follows:

$$x(t, \alpha) = \sqrt{\frac{2E_s}{T}} \cos(2\pi f_0 t + \phi(t, \alpha) + \phi_0) \quad (1)$$

where E_s is the energy per symbol, T is the modulation interval, f_0 is the carrier frequency, ϕ_0 is the initial phase, and $\alpha = (\dots, \alpha_{-1}, \alpha_0, \alpha_1, \dots)$ refers to a sequence of data symbols adopting one of the values from the set:

$$\alpha_i \in \{\pm 1, \pm 2, \dots, \pm(M-1)\} \quad (2)$$

where M refers to modulation valence.

Phase $\phi(t, \alpha)$, which carries information may be described with the following equation:

$$\phi(t, \alpha) = 2\pi h \int_{-\infty}^t \sum_{i=-\infty}^{\infty} \alpha_i g(\tau - iT) d\tau \quad (3)$$

where h is the modulation index defining the value by which the phase changes in each modulation interval. The function $g(t)$ is a frequency impulse with duration LT . A frequency impulse may last for one modulation interval or longer. An impulse lasting only for the modulation interval ($L=1$) classifies the system as a full response system, or otherwise ($L>1$), the system is a partial response system. Apart from the frequency impulse duration, CPM signals are defined by the modulation index h , modulation valence M and frequency impulse shape.

The shape of a frequency impulse is one of the parameters affecting the spectral properties of CPM signals. The most popular frequency impulses are: a rectangular impulse (REC), a raised-cosine impulse (RC), and a Gaussian-curve-shaped impulse. A rectangular impulse is characterized by a constant instantaneous frequency value and a linear change of phase in each modulation interval. Raised-cosine and Gaussian-curve impulses are characterized by better spectral properties (a strong concentration of the main lobe around the carrier frequency and a low level of side lobes) than the rectangular impulse.

Spectral properties of CPM signals also depend on the value of the modulation index defined as the ratio of two natural numbers. As the modulation index h grows, the bandwidth increases, resulting in the deterioration of spectral properties.

The paper considers the full response CPM system with, REC, RC, and Gaussian impulses and modulation valence $M=2$ or 4. The analyzed system employs 2x4 antenna configurations.

III. STTC CODING

The general structure of an STTC encoder is shown in Fig. 1 [6]. The encoder input data in each modulation interval t form a block of binary information described as:

$$c_t = [c_t^1, c_t^2, \dots, c_t^m], \quad m = \log_2 M \quad (4)$$

The encoder output in a given modulation interval is described by the sequence:

$$x_t = [x_t^1, x_t^2, \dots, x_t^{n_T}]^T \quad (5)$$

where n_T is the number of transmit antennas, and T denotes the transpose of the vector $[\]$. Each input sequence is fed to the shift register and multiplied by the coefficient of the encoder matrix. Finally, the STTC output signal for the i -th antenna and a modulation interval t is described by the formula:

$$x_t^i = \sum_{k=1}^m \sum_{j=0}^{v_k} g_{j,i}^k c_{t-j}^k \text{ mod } M, \quad i = 1, 2, \dots, n_T \quad (6)$$

where $g_{j,i}^k$ are generating matrix coefficients ($k = 1, 2, \dots, m; j = 1, 2, \dots; v_k, i = 1, 2, \dots, n_T$), m is the number of the encoder's shift registers, v_k is the number of memory cells of k -th shift register, and n_T is the number of transmit antennas.

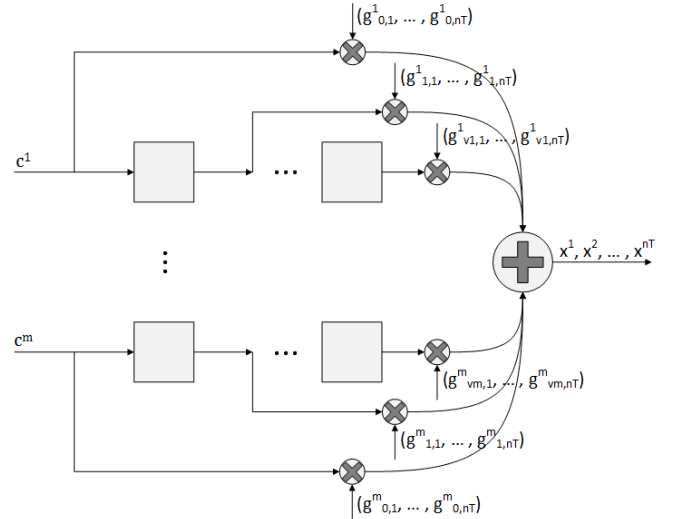

Fig. 1. Scheme of the STTC encoder

An STTC encoder can be described by means of a trellis which defines the output and the next state into which the encoder passes under the influence of input bits. The number of encoder states is determined by the equation:

$$n = 2^v \quad (7)$$

where v is the total number of memory cells for a given encoder.

IV. SYSTEM DESCRIPTION

The present work considers the reception of CPM signals for a transmission in an uplink connection in a system employing the MIMO technique, STTC coding and FDMA. The studies were aimed at the evaluation of transmission quality in the system under analysis. Figure 2 shows a block diagram of the proposed system. At the input, each k th user binary information sequence $\mathbf{a}_{0,\dots,k-1}$, is Convolutional Encoded (CE), interleaved (Int.) and converted into several (M_T) parallel streams in STTC encoder. Each data stream is conveyed to one of M_T CPM modulators. A rate 1/3 systematic recursive CE with four states and good distance properties [18] has been chosen. Its connection polynomials (in octal notation) are (7; 5; 3)₈, where 7₈ represents the coefficients of the feedback polynomial [19]. In order to achieve higher rates, the CE output is punctured as in [19]: a rate-matching algorithm is used to obtain appropriate coding rate R_C . The interleaver (Int.) is a symbol, spread (S-random) interleaver [20] whose parameters are set according to the code word size.

Each user's transmitter consists of an CE, interleaver, STTC encoder and a CPM modulator (Fig. 2). The efficiency of an STTC encoder depends on the number of transmit antennas. The STTC encoder considered in the paper use two transmit antennas. Each user signal is characterized by a distinct phase φ_k and delay τ_k , as typically occurs in uplink systems. Ideal power control is considered here. As a result, the received signal power is equal for all users.

In the analyzed system, a MIMO channel is considered. The system is composed of k users each of whom transmits signals via M_T transmit antennas. The receiver uses M_R antennas. The channel model used in simulation takes into account multipath propagation. The channel model has been implemented as a Taped Delay Line (TDL) and it models a channel with flat fading and Additive White Gaussian Noise (AWGN) [5].

Each receive antenna receives a faded superposition of the M_T simultaneously transmitted signals corrupted by additive white Gaussian noise. The fading is assumed to be flat and distributed according to a Rayleigh *pdf*. The random path gains between transmit antenna m and receive antenna p , $h_{m,p}(t)$, are independent complex Gaussian random variables with zero mean and variance per dimension 1/2. The fading is slow, such that the $M_T \times M_R$ fading coefficients are constant during a frame, but vary from frame to frame. The AWGN noise components $n_p(t)$, are independent zero-mean complex Gaussian random processes with power spectral density N_0 .

At the receiving end, the system consists of a MIMO MMSE/STTC detector/decoder and low-complexity iterative algorithm to ICI cancellation [7].

With the assumption of uniform parameters of CPM, and an equal number of transmit antennas M_T for each system user, the signal at the input of p -th receiver antenna is described by:

$$r_p(t) = \sum_{k=0}^{K-1} \sum_{m=0}^{M_T-1} \sum_{n=0}^{B-1} g_{k,m,n} \left(t - n\tau_k, \mathbf{a}_{k,m} \right) \cdot e^{j(2\pi k\Delta_f t + \varphi_k)} + n_p(t), \quad j = 0, \dots, M_R - 1 \quad (8)$$

where B is the number of intervals for which the STTC - CPM signal is transmitted.

The MMSE/STTC block realize the STTC decoding and computes the cost function, i.e., minimizes:

$$G_{MMSE} = \sqrt{\frac{n_T}{E_s}} \left(\mathbf{H}^H \mathbf{H} + \frac{n_T N_0}{E_s} \mathbf{I}_{n_T} \right)^{-1} \mathbf{H}^H \quad (9)$$

where H is the matrix of channel impulse response estimates, I - identity matrix, N_0 - spectral density of noise power, upper index of quantity H^H denotes the Hermitian transpose of matrix H and it is the sum of the operations of transpose and complex conjugate of the matrix. The signal \mathbf{y} from MMSE/STTC reaches the ICI cancellation block. The receiver carries out ICI cancellation through a set of single-user MAP detector/remodulator blocks, as described by Perotti et al. [7]. The remodulators make use of the output of the MAP detector to compute the remodulated signal $s_k^{(i)}(t)$ relative to the k th user and i th iteration. The channel decoder performs two iterations loops. The *inner* loop is formed by the ICI canceller, the MAP detector, the CPE SISO decoder and the remodulator, while the *outer* loop involves the CPE SISO decoder, the CE SISO decoder, the interleaver and the deinterleaver between the inner CPE decoder and the outer CE decoder. ICI cancellation can be performed while executing the decoding iterations to enhance the receiver performance. In such case, after the inner CPE decoder is executed, remodulation is performed. Then, interference cancellation is performed and the CPM receiver, including the inner CPE decoder, is again executed. The decoder starts decoding a received code word executing N_{IC} *inner* iterations. Then, it executes N_D times an *outer* iteration followed by an inner iteration. This way, ICI cancellation is performed as part of the decoding iterations and it results in an improved ICI cancellation [7]. On the final *outer* iteration, a

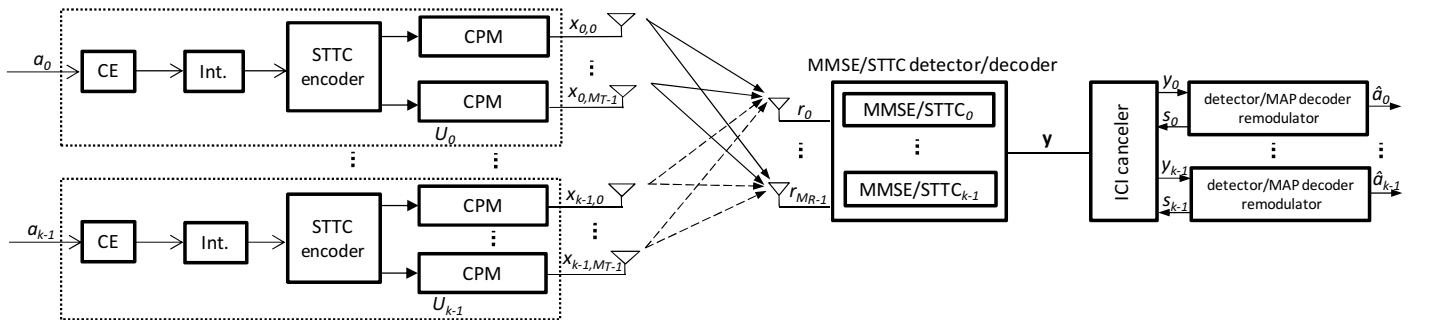

Fig. 2. Block diagram of the MU STTC FDMA-CPM system

decision is made on the transmitted data symbols $\hat{a}_0, \dots, \hat{a}_{k-1}$.

In the analyzed system, data are transmitted in blocks. The maximum number of transmitted bits is expressed by the following equation:

$$N = N_{Bits/Block} \times N_{Blocks} \times N_{Ch} \quad (10)$$

where $N_{Bits/Block}$ denotes the number of bits transmitted in a single block, N_{Blocks} is the number of blocks, and N_{Ch} is the number of channels in the system.

V. SIMULATION RESULTS

By means of the Monte Carlo computer simulation, the bit error rate (BER) has been determined for the above-described FDMA system with CPM modulation and STTC coding. The simulations have been performed with the aid of a simulation program written in C++ using IT++ libraries, ver. 4.2. The analysis assumed that each user transmits CPM signals with the same modulation and coding parameters, and of equal strength.

It was assumed that the standardized value of the interval between the carrier frequencies of consecutive channels $\Delta_f T$ in the system is equal to $3/4$, and that the transmission is performed via four neighboring channels. The transmitted packages were 1000 bits long. The simulation was stopped if at least 100 errors occurred.

The analysis has been performed with reference to binary and quadrature CPM modulation with the parameters $h=1/2$ and $L=1$ and different shapes of the frequency impulse.

The number of iterations in the receiver was experimentally fixed as a good trade-off between receiver performance and complexity. Two ICI cancellation iteration (NIC=2) is performed before decoding, then four decoding iterations ($N_D=4$) are performed. The CPM modulator is concatenated with STTC encoder with generating matrices $g1 = \begin{bmatrix} 0 & 2 \\ 2 & 0 \end{bmatrix}$ and $g2 = \begin{bmatrix} 0 & 1 \\ 1 & 0 \end{bmatrix}$. STTC encoder structure has been selected on the basis of the information provided in [6].

Figures 3 and 4 illustrate BER for the studied systems. Based on the BER results obtained (Fig. 3), it may be stated that when transmission is performed for four users in parallel MSK (Gaussian frequency impulse (GAUSS), rectangular frequency impulse (REC) and rice cosine impulse (RC) and with a reduced distance between subcarriers $\Delta f T=3/4$), the BER at the level of 10^{-5} is higher in the range 0.5-1.5 dB than the BER obtained by a system with a single user, i.e., in the case when ICI does not occur (no ICI, REC SU). Fig. 4 also shows the so-called error background. It is determined for E_b/N_0 from the value of about 3.5 dB and it results from the fact that the applied receiver does not completely eliminate ICI.

Fig. 4 presents BER for systems employing quadrature CPM modulation. In this case, each of the four users transmitted signals via two transmit antennas, and the receiver used four receive antennas. In this scenario, the error rate at the BER level of 10^{-5} obtained for multiple-user systems was worse than the one obtained for an ICI-free system by at least 1 dB. It

should be noted that, like for MSK modulation, the so-called error background appears.

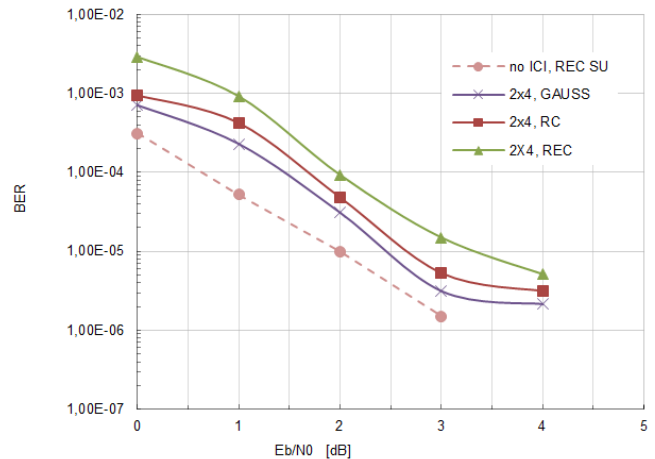

Fig. 3. BER for system ($h=1/2$, $M=2$, $L=1$, $\Delta f T=3/4$), 4-users

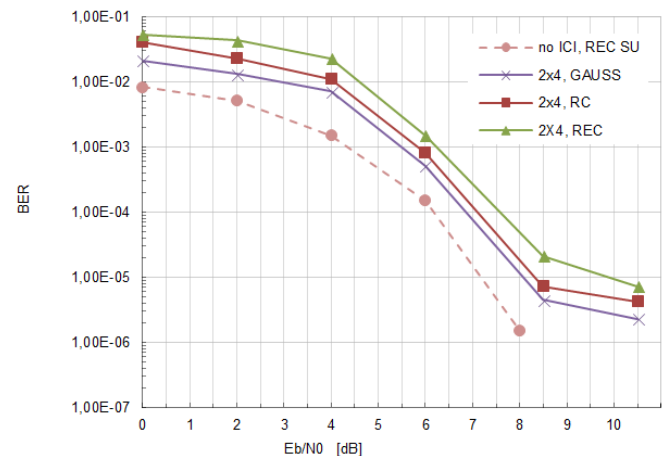

Fig. 4. BER for system ($h=1/2$, $M=4$, $L=1$, $\Delta f T=3/4$), 4-users

VI. CONCLUSION

In this paper, a multiuser STTC FDMA-CPM system has been proposed. Through MMSE-based multiuser detection and low-complexity iterative ICI cancellation, considerable improvements in both BER are achieved with respect to single antenna systems, while the multiuser receiver complexity is kept low. The performance evaluation has been presented to demonstrate the superiority of the proposed multiuser FDM-CPM MIMO systems. The study shows that it is possible to increase transmission efficiency by using CPM modulation and STTC coding for MU transmissions, but the obtained bit error rate is worse than the one achieved for a n ICI-free system by at least 0.5 to 3 dB (for BER in the order of 10^{-5}).

ACKNOWLEDGMENT

The work has been funded by the Polish Ministry of Science and Higher Education within the status activity task “no. DSPB-0154/15” in 2015.

REFERENCES

- [1] J. B. Anderson, T. Aulin, and C. E. Sundberg, *Digital Phase Modulation*, Plenum Press, 1986.
- [2] J.G. Proakis *Digital Communications*, McGraw-Hill, New York, 2001, 4th ed.
- [3] Bluetooth SIG, “Specifications of the Bluetooth System – core”, Technical Specification Version 1.1, Bluetooth SIG, February 2001.
- [4] A. J. Rodrigues, A. A. Albuquerque, „Diversity techniques with multi-h CPM for satellite mobile systems”, IEEE 46th Vehicular Technology Conference, 1996, vol. 1, pp. 551 – 555.
- [5] E. Biglieri, *MIMO wireless communications*, Cambridge Univ Pr, 2007.
- [6] B. Vucetic, J. Yuan. *Space – Time Coding*, Wiley Editorial Offices, 2003.
- [7] A. Perotti, S. Benedetto, P. Remlein, „Spectrally efficient multiuser CPM Systems”, IEEE International Conference on Communications (ICC 2010), Cape Town, South Africa, May 2010, doi: 10.1109/ICC.2010.5501939.
- [8] B. E. Rimoldi, „A Decomposition Approach to CPM”, IEEE Transactions on Information Theory, 34, 1988, pp. 260-270.
- [9] X. Zhang, M. P. Fitz, “Space-time code design with CPM transmission,” in Proc. Int., Symp. Inform. Theory, Washington, DC, June 2001, p. 327.
- [10] X. Zhang, M. P. Fitz, “Soft-Output Demodulation Space-Time-Coded Continuous Phase Modulation,” IEEE Transactions on Signal Processing, vol. 50, pp. 2589–2598, Oct. 2002.
- [11] X. Zhang, M. P. Fitz, “Space-Time Code Design with Continuous Phase Modulation,” IEEE Journal on Selected Areas in Communications, vol. 21, pp. 783–792, June 2003.
- [12] C.-C. Chen, C.-C. Lu, “Space-time code design for CPFSK modulation over frequency-nonslective fading channels,” IEEE Trans. Commun., vol. 53, no. 9, pp. 1477–1489, Sept. 2005.
- [13] B. Özgül, M. Koca, H. Deliç, “Orthogonal Space-Time Block Coding for Continuous Phase Modulation with Frequency-Domain Equalization”, IEEE Trans. Commun., vol. 57, no. 12, pp. 3579–3584, Dec. 2009.
- [14] G. Wang and X.-G. Xia, “Orthogonal space-time coding for CPM system with fast decoding,” in Proc. Int. Symp. Inform. Theory, 2002, p. 107.
- [15] S. M. Alamouti, “A simple transmitter diversity scheme for wireless communications,” IEEE J. Select. Areas Commun., vol. 16, no. 8, pp. 1451–1458, Oct. 1998.
- [16] M. Hesse, J. Lebrun, L. Deneire, “L2 orthogonal space time code for continuous phase modulation,” in Proc. of IEEE orkshop on Signal Processing Advances in Wireless Communications (SPAWC’08), July 2008, pp. 401 – 405.
- [17] M. Hesse, J. Lebrun, L. Deneire, “Full Rate L2-Orthogonal Space-Time CPM for Three Antennas,” IEEE Globecom, pp. 3633-3637, 2008.
- [18] A. Perotti, A. Tarable, S. Benedetto and G. Montorsi, “Capacity-achieving CPM schemes,” IEEE Transactions on Information Theory, vol. 56, Apr. 2010, pp. 1521-1541.
- [19] R. L.Maw and D. P. Taylor, “Space-Time Coded Systems using Continuous Phase Modulation,” IEEE Transactions on Communications, vol. 55, Nov. 2007, pp. 2047-2051.
- [20] D. Divsalar and S. Dolinar, “Weight Distributions for Turbo Codes Using Random and Nonrandom Permutations,” JPL TDA Progress Report, vol. 42-122, April-Jun 1995, pp. 56-65.