

# Smart Antenna System for VANET (Vehicular Ad-hoc Networking Communications)

Hak-Lim Ko<sup>1</sup>, Seung-Goo Lee<sup>1</sup>, Dae-Young Cho<sup>1</sup>, Hyun Seo Oh<sup>2</sup>, Jong Won Park<sup>3</sup>,  
Yong Kon Lim<sup>3</sup>

<sup>1</sup>Department of Information & Communications Engineering, Hoseo University  
165 Sechul-ri, Baebang-myun, Asan-si, Choongnam-do, Korea, 336-795  
E-Mail: hlko@hoseo.edu

<sup>2</sup>ETRI, 161 Gajeong-dong, Yuseong-gu, Daejeon, Korea, 463-020

<sup>3</sup>KORDI, 104 Sinsungro, Yuseong-gu, Daejeon, Korea, 136-701

## Abstract

In this paper, we have studied the implementation and adaptation of a smart antenna system for vehicular ad-hoc communication systems. We have designed a smart antenna system with switching beam structure in order to reduce the hardware and computational complexity. In the architecture, we have proposed the new switched beam structure in order to allow directional and omni-directional communication in a single architecture. Also, by using the proposed architecture, we can use the same MAC protocols as the ones used in WAVE communications while achieving directional communications instead of the directional MAC protocols, which may increase the computational overhead.

**Keywords :** beamforming VANET Testbed

## 1. Introduction

Telematics provides lots of convenient information to the users in a car using ad-hoc communications between moving vehicles. Recently, 5.8 GHz WAVE communication has been studied for mobile ad-hoc communications between moving vehicles.

In this paper, we have studied the implementation and adaptation of a smart antenna system for vehicular ad-hoc networking (VANET) systems in order to increase the performance of the WAVE communications.

The smart antenna system[1] focuses the main beam to the desired signal direction while simultaneously reducing the signals received from directions other than the desired one by optimally combining the signal received at the antenna array. Resulting, increase of the SINR, reliable communication range, and frequency reuse rate and decrease of the BER, interference coming from other than the desired direction, and the effect of the multipath fading. Therefore, the throughput of the VANET system can be increased by adapting the smart antenna technologies.

However, adapting the smart antenna techniques to the vehicular ad-hoc communication systems will add a noticeable amount of hardware and software complexity to the terminals equipped in a car. Therefore, in this research we use a switching beam based beamforming structure to implement a smart antenna system for VANET terminals in order to minimize the increase of hardware and software complexity due to the adaptation of the smart antenna technologies.

Moreover, in vehicular communications, emergency signals and control signals may use omni-directional communications and typical data may use directional communications for safety and reliable communications. Therefore, directional and omni-directional communications have to be allowed in a single structure. Also for directional communications, we can not use the same MAC protocols as the ones used in WAVE communications because of the hidden terminal and deafness problems. And we have to modified the MAC protocol in order to support the directional communications (directional MAC protocols) which requires lots of computational overhead. Therefore, in this research, we proposed new switching beam antenna structures for the directional VANET communications in order to solve these problems

## 2. SMART ANTENNA SYSTEM

The smart antenna system focuses the main beam to the desired signal direction while simultaneously reducing the signals received from directions other than the desired one by optimally combining the signal received at the antenna array. The smart antenna system can be implemented using either the adaptive beam antenna architecture or the switching beam antenna architecture. In the adaptive beam antenna architecture, the system adaptively tracks the desired vehicle's direction and performed beamforming to the estimated direction by optimally combining the signal transmitted/received at the array antenna. On the other hand, the switching beam antenna structure divides the communication area into several small beam directions and selects the best beam direction in order to receive the signal from the selected direction. In general, it is known that the switching beam antenna structure achieves less performance benefits but requires less hardware complexities and computational time when compared to the adaptive array antenna architecture.

In [2], Lee et al., shows that the effect of multipath fading and RMS delay spread can be reduced significantly by adapting the smart antenna technologies to the ad-hoc communications between moving vehicles by analyzing the performance of the smart antenna system using the measurement data collected from real channel environments. And, the reliable communication range can be increased from not only the beamforming gain but also the gain obtained by reducing the effects of fading. Also, the frequency reuse rate can be increased by adapting the smart antenna technologies to the VANET communication systems. Therefore, the throughput of the VANET system can be increased by adapting the smart antenna technologies.

## 3. IMPLEMENTATION OF THE SMART ANTENNA TESTBED for the VANET terminals.

In this study we implemented the switching beam based smart antenna system on vehicular ad-hoc communication terminals in order to reduce the hardware and software complexity of adding smart antenna technologies in the terminals. Figure 1 shows the block diagram of the switching beam antenna structure that we implemented for vehicular ad-hoc communications.

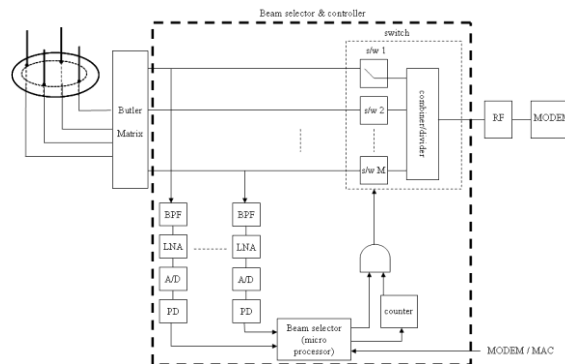

Figure 1. Block Diagram of the smart antenna system in vehicular ad-hoc communication terminals.

As we can see in Figure 1, we used a 2x2 array antenna with a 4x4 butler matrix implementation at its end. This enabled the system to form four different beam signals and we used the beam selector to select the desired beam direction from the four outputs of the butler matrix. This results in controlling the switch to receive signals from a desired beam direction and the same beam direction is used when transmitting signals from the mobile terminals as well. In this work the beam selector uses the power detector to select the beam signal with the highest power from the four output signals of the butler matrix. This information from the beam selector is passed on the switch to select the best beam signal for communication. Also, we design four 2x1 switches at the end of the Butler Matrix and allow the beam selector to control these switches. This allows directional and omni-directional communication in a single architecture. Specifically, when all four 2x1 switches are on, omni-directional communication is enabled and if a single switch is selected, directional communication can be achieved. Furthermore, turning on multiple switches will allow the

communication to the selected directions. As a result, in vehicular communications, emergency signals and control signals can use omni-directional communications and typical data can use directional communications.

Additionally, when communicating using the beam direction where the signal strength of a desired frequency is the highest in a switching beam architecture, if a higher signal strength is detected from a direction other than the selected beam direction, a problem where the beam direction automatically switches may occur. Therefore, in the architecture presented in Figure 1, we add an AND gate and a counter at the end of the beam selector so that the beam switching does not occur before the counter outputs a '1' signal. As a result, beam directional switching does not happen before the communication at the currently used direction is over.

Also, we have allowed the counting time at the counter to be controlled using the estimate of the end of the MAC communication times using the demodulation of the initial signal. Therefore, when designing a directional antenna for vehicular communications, we can use the same MAC protocols as the ones used in WAVE communications while achieving directional communications instead of the directional MAC protocols, which may increase the computational overhead. The detailed block diagram of Figure 1 is presented in Figure 2.

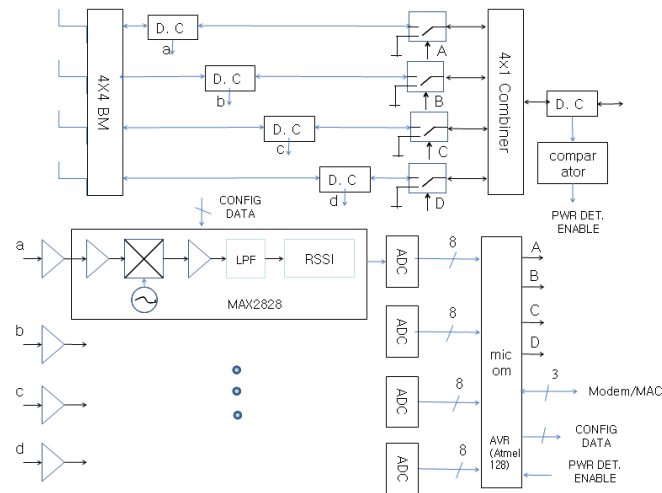
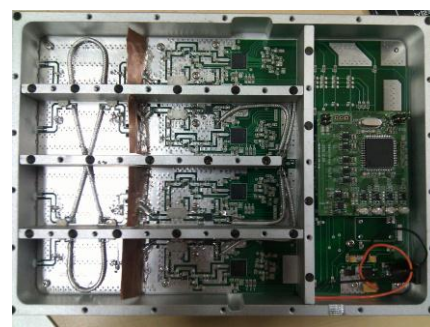

Figure 2. Block Diagram of the details of the smart antenna system.

As one can notice in Figure 2, when multiple beam directions are beamformed using the Butler Matrix, the beam selector chooses the beam direction where the highest RSSI is detected for the desired frequency among the beamformed directions. This information is stored in the microcontroller. And the microcontroller controls the switch that controls the desired beam directions with the information from the MAC layer. At this point, the beam selection can be derived from the control of the MAC layer. Therefore, directional communications or omni-directional communications can be selected by the control of the MAC layer.



(a) 2x2 array antenna.



(b) Circuit design of the butler matrix, beam selector with the controller.

Figure 3. Design of the smart antenna testbed for VANET terminals.

Figure 3(a) shows the 2x2 array antenna. As we can notice in Figure 1, in this paper we use a 2x2 planar array antenna with distances between the antennas being a half wave length of the 5.8GHz carrier frequency for designing a smart antenna system for vehicular communications. Figure 3(b) shows the circuit design of the 4x4 butler matrix and the beam selector with the controller. The left of Figure 3(b) presents the Butler Matrix and the right implements the beam selector with the beam controller. Also, note that the beam selector and beam controller gets its input from the 2x2 array antenna (Figure 2) to transmit the beamformed signal to the vehicular communication modem and also receives the signal from the modem to form beam signals for further transmissions.

The integrated smart antenna testbed that combines Figure 3 is presented in Figure 4. Using such a smart antenna testbed installed in vehicles we are performing performance validations.



Figure 4. Integrated smart antenna testbed.

## 4. CONCLUSION

In this work we have studied the implementation and adaptation of a smart antenna system for VANET (vehicular ad-hoc networking) terminals. We have designed a smart antenna system with switching beam structure in order to reduce the hardware and computational complexity. In the architectures, we have proposed the new switched beam structure in order to allow directional and omni-directional communication in a single architecture. Also, by using the proposed architecture, we can use the same MAC protocols as the ones used in WAVE communications while achieving directional communications instead of the directional MAC protocols, which may increase the computational overhead. Also, we have implemented the proposed smart antenna architecture and using the implemented testbed installed in vehicles we are performing performance validations.

## References

- [1] J. C. Liberti, Rr. And T. S. Rappaport, Smart Antennas for Wireless Communications : IS-95 and Third Generation CDMA Applications, Prentice Hall, Upper Saddle River, NJ, 1999.
- [2] S. Lee, B. Park, D. Lee, D. Lee, H. Ko, and J. Ko, "Performance Analysis of Beamforming Techniques in Ad-hoc Communication Between Moving Vehicles," Proc. APCC 2007, Bangkok, Thailand, pp. 185-189, 2007.

## Acknowledgments

This work was conducted as a part of the research projects of "Research on fundamental core technology for ubiquitous shipping and logistics" financially supported by the Ministry of Land, Transport and Maritime Affairs (MLTM) of Korea.