

A 5.7-GHz Horizontally-Polarized Omnidirectional Printed WLAN Antenna

H.-R. Chuang, S.-W. Kuo, and C.-C. Lin
 Department of Electrical Engineering,
 National Cheng Kung University, Tainan, Taiwan, R.O.C
 Tel: +886 6 2757575~62374 Fax: +886 6 2748690,
 E-mail: chuangh@ee.ncku.edu.tw <http://empc1.ee.ncku.edu.tw/>

1. INTRODUCTION

In the urban or indoor wireless environment, after complicated multiple reflection or scattering, the polarization of the propagating radio wave may change significantly. It has been reported that, using horizontally polarized antenna at both the transmitter and receiver will result in 10dB more power (in the median), as compared to the power received using vertically polarized antennas at both end of the link. This paper presents the design simulation, fabrication, and measurement of a 5.7GHz omnidirectional horizontally polarized planar-printed antenna for 802.11a WLAN application. The HFSS 3-D EM simulator is used for design simulation. The antenna is fabricated on a double-sided FR-4 printed circuit board. In addition to be used alone for a horizontally polarized antenna, it can be also a part of a diversity antenna.

As reported in [1][2] that, although many current wireless system are vertically polarized, it has been predicted that using horizontally polarized antenna at both the transmitter and receiver will result in 10dB more power (in the median), as compared to the power received using vertically polarized antennas at both end of the link. A printed IFA (inverted-F antenna) is a popular choice to be used in a WLAN card [2]. The dominant polarization of an IFA printed on a PCMCIA card and placed horizontally (to be inserted inside a notebook PC) is basically horizontal (and has a certain degree of omnidirectional H-plane pattern). In this paper a 5.7-GHz horizontally polarized planar antenna which uses the Alford-loop-structure [3-5] to achieve an omnidirectional pattern is designed for WLAN applications.

2. ANTENNA DESIGN

In order to achieve horizontally polarized radiation, a loop antenna is a suitable choice. A loop antenna with a uniform current distribution will have an omnidirectional pattern. However, a small loop antenna will have a very small radiation resistance and a high reactance. This will cause difficult impedance matching problem. A larger loop antenna will have a reasonable radiation resistance. But the antenna current distribution along the loop becomes nonuniform and hence could not yield a desired omnidirectional pattern. To design a loop antenna with an omnidirectional pattern and an acceptable input impedance matching becomes a design challenge. In [3] the Alford loop structure [4] is adopted to design a 900 MHz planar printed omnidirectional horizontally polarized antenna. Here the same structure is used for 2.4 GHz design. As shown in the Fig. 1, a printed "Z" strip is on the top plane and the other one is on the bottom plane. The "Z" strip on the bottom plane is arranged in such a manner that, the "arm" is mapped to that of the "Z" strip on the top plane through the substrate. And the "wings" of two "Z" strips form a "loop"-type structure (though separated by the substrate). The "wing" length of the Alford loop is of the order of a quarter of wavelength. A connector linked the top and bottom strip is located at the center of the "arm".

Due to structure symmetry, the antenna current distribution on two strips will have the same magnitude and 180-degree phase difference. This is illustrated in Fig.2 (left). Since the (substrate) distance between the top and bottom strip is very small, the radiation of the antenna current along the "arm" will cancel by each other. The currents on two "wings" of each "Z" strip establish a rectangular "loop"-type current distribution. This "loop"-type current distribution will radiate a horizontally polarized wave and is expected to have an omnidirectional pattern, as illustrated in 2 (right).

The required dimension of the "Z" strip, such as, the length and width of the "arm" and the "wing",

should be carefully designed for good antenna impedance match at the desired frequency band. The length of the "wing" is approximately a quarter-wavelength long. However, the exact length and width are remained to be fine-tuned. The Ansoft HFSS 3D-FEM simulator is used for the design simulation. Fig. 3 shows the HFSS design simulation schematics of a 5.7-GHz planar printed Alford-loop antenna. The antenna current distribution, input impedance, and polarization/radiation patterns can be computed.

3. SIMULATED AND MEASURED RESULTS

Fig. 4 shows a photograph of the designed antenna fabricated on a FR-4 PCB substrate with a 1mm-thickness. A SMA connector is used to connect the central feed point of the top and bottom "Z" strips. This is for design verification. For practical WLAN card with a PCB thickness of 6 mil, the designed printed antenna can be much smaller. The measured VSWR is less than 2 from 5.725 to 5.825 GHz. The simulated and measured radiation patterns of E_θ field (horizontal polarization) at 5.8 GHz is shown in Fig. 5. As expected, the H-plane pattern has an omni-directional horizontal polarization (E_θ) field. The measured average antenna gain of the E_θ field in H-plane is -1.2dBi at 5.8GHz and is about -15dBi for the E_ϕ field.

Fig. 6 (top) shows a simple model for a notebook PC housing which consists of three parts: the display, the screen (inside the display) and the keyboard (including a metallic box inside). The material of display is PEC-covered polyethylene ($\epsilon_r = 2.25$), the setups of screen and keyboard are glass ($\epsilon_r = 5.5$, $\sigma = 10^{-12}$ S/m) and polyethylene with a metallic box inside, respectively. Fig. 6 (bottom) shows the HFSS simulation schematics with the designed printed antenna and simulated E-field distribution around the antenna situated proximate to the PC housing. The simulated and measured antenna patterns will be shown in the meeting.

4. CONCLUSION

The design simulation, fabrication, and measurement of a -5.7-GHz horizontally polarized omnidirectional planar-printed antenna are presented for 802.11a WLAN application. The antenna is fabricated on a double-sided FR-4 printed circuit board for design verification. The measured VSWR is less than 2 from 5.725 to 5.825 GHz. As expected, the H-plane pattern has an omni-directional horizontal polarization (E_θ) field. The measured average antenna gain in H-plane at 5.8GHz is -1.2dBi for the E_θ field and about -15dBi for the E_ϕ field. A simple model for a notebook PC housing, which consists of the display, the screen (inside the display) and the keyboard (including a metallic box inside), is constructed. The material of display is PEC-covered polyethylene ($\epsilon_r = 2.25$), the setups of screen and keyboard are glass ($\epsilon_r = 5.5$, $\sigma = 10^{-12}$ S/m) and polyethylene with a metallic box inside, respectively. The HFSS simulation schematics for the designed printed antenna situated proximate to the PC housing is performed. The simulated and measured antenna patterns will be shown in the meeting.

REFERENCE

- [1] Dmitry Chizhik, Jonathan Ling, and Reinaldo A. Valenzuela, "The Effect of Electric Field Polarization on Indoor Propagation," IEEE ICUPC, Florence Italy, 1998.
- [2] C. Soras, M. Karaboikis, G. Tsachtsiris, and V. Makios, "Analysis and Design of an Inverted-F Antenna Printed on a PCMCIA Card for the 2.4GHz ISM Band," *IEEE Antennas and Propag. Magazine*, vol. 44, no. 1, pp. 37-44, Feb. 2002.
- [3] H.-R. Chuang, et al., "Omni-Directional Horizontally Polarized Alford Loop Strip Antenna", US patent 5,767,809, June 1998.
- [4] A. Alford and A. G. Canadian, "Ultra-high frequency loop antenna," *Trans. AIEE*, vol. 59, pp. 8443-8448, 1940.
- [5] C.-C. Lin and H.-R. Chuang, "A 2.4GHz Omni-directional Horizontally Polarized Planar Printed Antenna for WLAN Applications," 2003 IEEE International Symposium on Antennas and Propagation, Columbus, USA, June 2003.

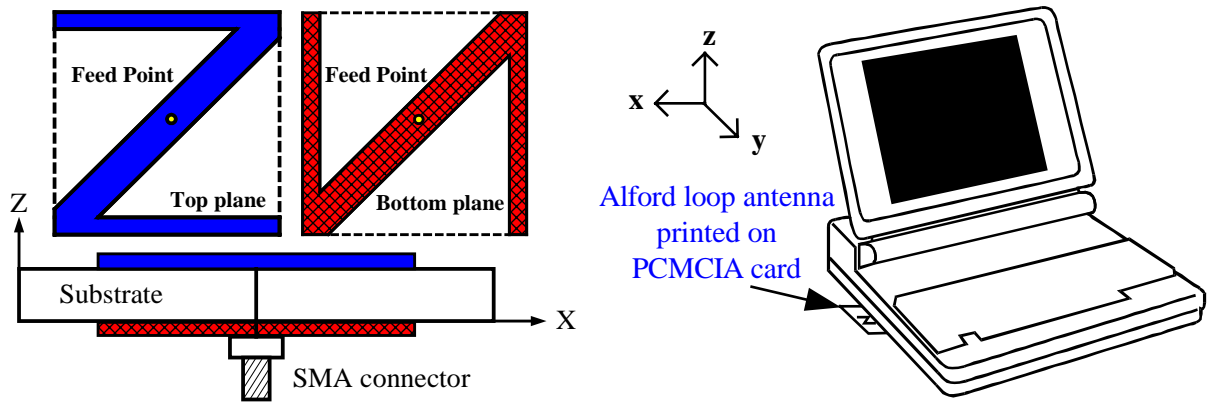

Fig. 1. Illustration of a planar printed Alford-loop antenna for WLAN application

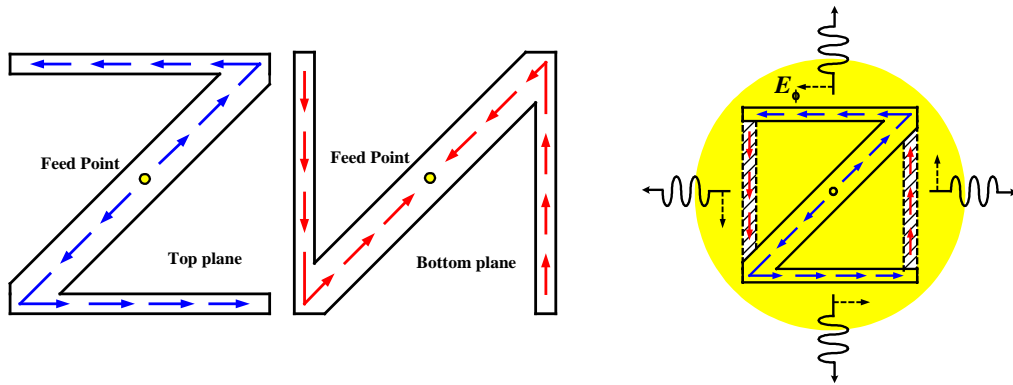

Fig. 2. Illustrations of the current distributions and horizontally polarized omni-directional patterns of a planar printed Alford loop antenna.

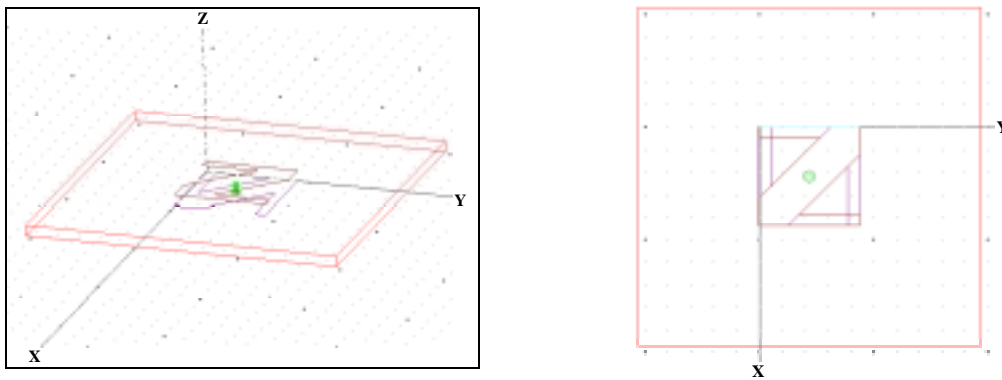

Fig. 3. Illustration of HFSS simulation.schematics.

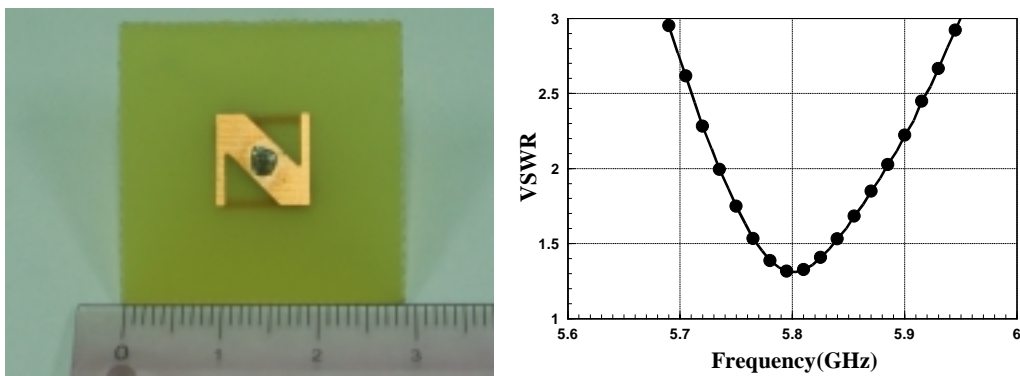

Fig. 4. Photograph of a fabricated antenna on a FR-4 substrate and measured VSWR.

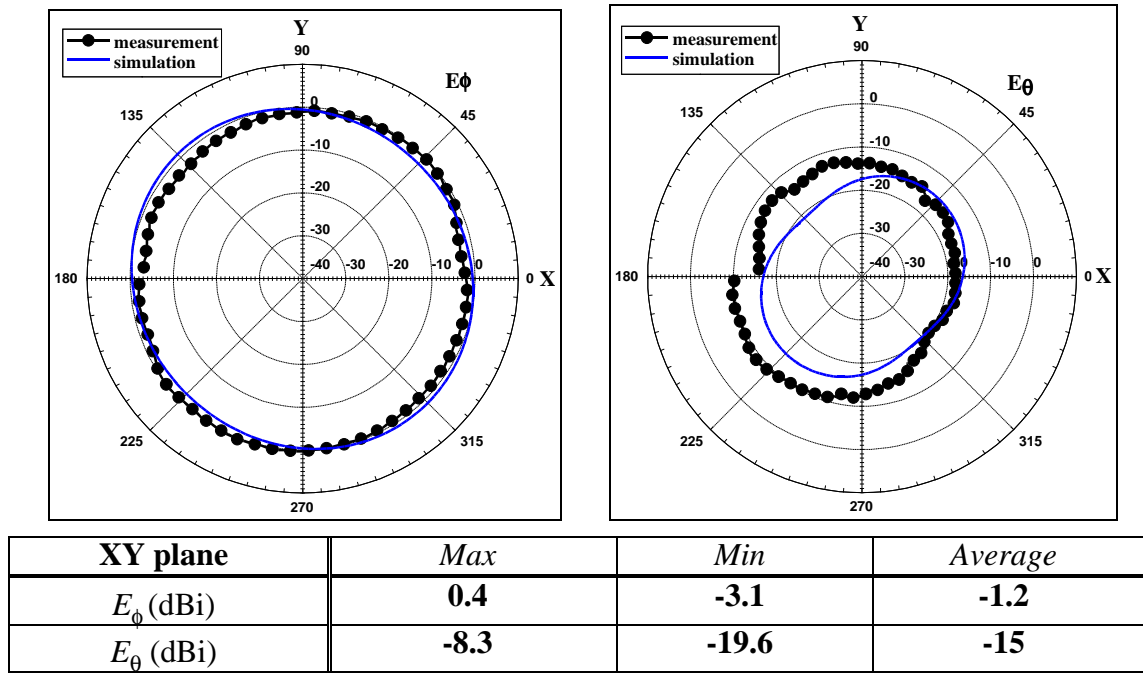

Fig. 5 H-plane radiation patterns and antenna gain at 5.8 GHz

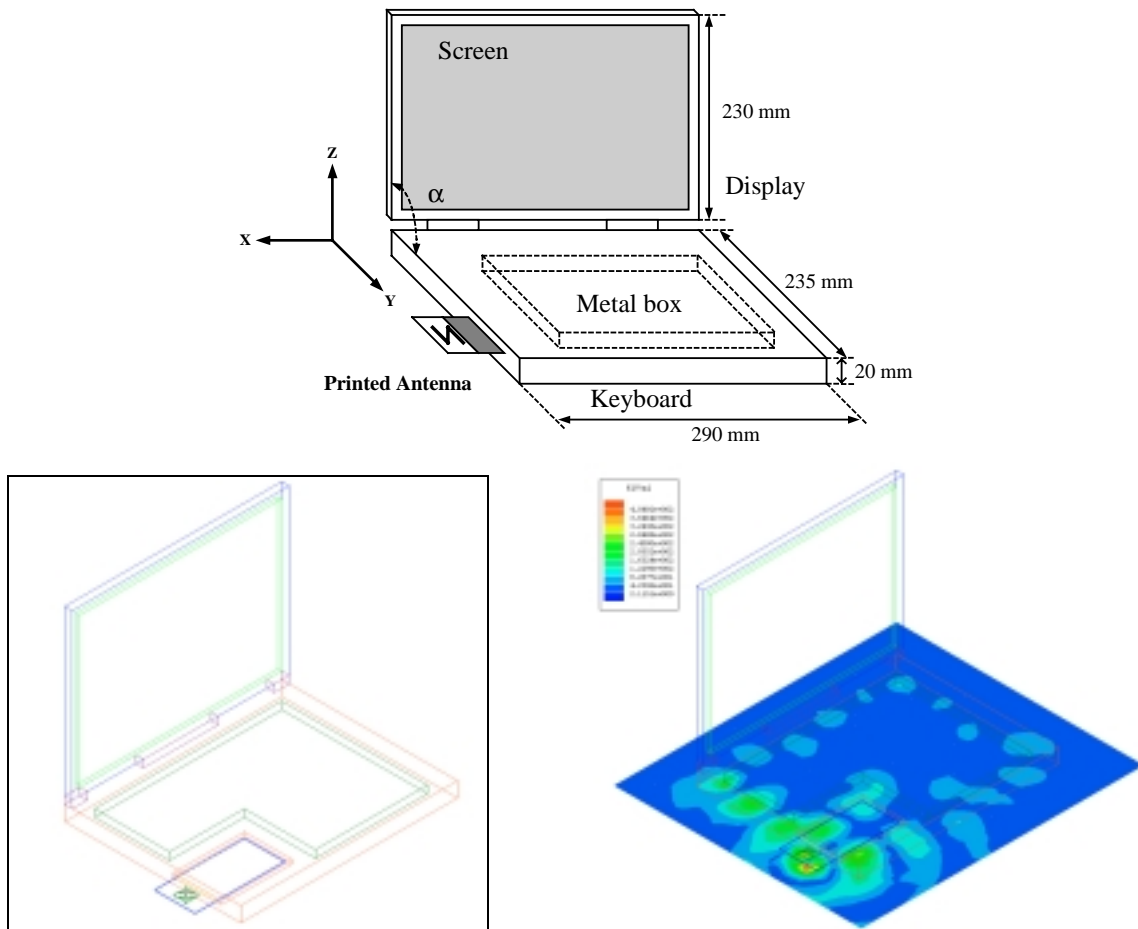

Fig. 6. Geometry and dimensions of the notebook PC modeling with the antenna and the HFSS simulation schematics with the simulated E-field distribution around the antenna.