

A Switchable RHCP/LHCP Slot-Ring Antenna

Min-Hua Ho^{1*}, Ming-Ting Wu², Chung-I G. Hsu², Jia-Yi Sze³

¹Electronic Eng. Dept., National Changhua Univ. of Education, ²Electrical Eng. Dept.,
Da-Yeh Univ., ³Electrical Eng. Dept, Chung-Cheng Institute of Technology
1, Jinn-Der Rd., 500 Changhua City, Taiwan R. O. C.
ho@cc.ncue.edu.tw, miting_wuu@yahoo.com.tw, szejy@ccit.edu.tw

1. Introduction

Antenna systems that possess polarization diversity are attracting more attention in modern wireless communications. In wireless local area networks (WLAN) [1], the polarization diversity of antennas is utilized to alleviate the channel deterioration caused by multipath fading effects. Usually, the polarization diversity is obtained by feeding antennas at distinct locations [2]. In recent papers [3-5], several antenna architectures have been proposed to obtain polarization diversity electrically. They use shorting pin-diodes implemented on the antenna structures to switch the polarization of the antennas. In [3] a square patch is excited by a pair of cross-oriented slots fed by a microstrip. The switching process between right-hand circular polarization (RHCP) and left-hand circular polarization (LHCP) is inserted in the antenna with four beam-led pin-diodes soldered across the coupling slots. The polarization sense of the antenna of [4] is similar to that of [3] with the former using only two pin-diodes and a coaxial line feed. In contrast to [3, 4], a pair of near degenerate-modes of an annular ring [5] are excited to achieve circular polarization (CP). From these antennas, by alternatively shortening one or two of those mounted pin-diodes using a dc-bias circuit, an LHCP or RHCP radiation pattern can be excited.

So far the polarization diversity antennas reported in the literature are of two-side circuits or even multi-layered structures which may cause a fabrication complexity problem. Besides, these antennas should be of low cost for applications in modern communication systems. Hence, we propose a switchable CP antenna using a uniplanar slot-ring fed by a slotline on the same circuit side. The antenna designed for 2.4 GHz range is built on a low-cost FR4 dielectric. Two pin-diodes are mounted on the antenna to electrically alter the polarizations. Furthermore, the antenna has the advantage of easy integration of active components due to its uniplanar configuration. In this paper, we will also present the design method of the antenna and its performance.

2. Antenna design

A slot-ring can possess two degenerate-modes with the same resonant frequency. The degenerate-modes are split by introducing perturbations in the diagonal line of the ring. These split degenerate-modes are mutually orthogonal having a 90-degree phase difference. Shown in Fig. 1(a) is the basic CP antenna configuration (denoted as antenna A). The antenna's dimensions are $l=85$ mm, $R_{in}=10.5$ mm, $R_o=11.8$ mm, $W=2$ mm, $D_p=12$ mm, $S_p=.7$ mm, $g=.5$ mm, $S_L=8.9$ mm, $S_w=4.3$ mm, $L_s=25.2$ mm, $R_s=6$ mm, $\theta=50^\circ$, $W_{cpw}=3$ mm, and $G_{cpw}=.3$ mm. The dielectric substrate has a relative dielectric constant 4.4 with its thickness equal to 1.6 mm. A rectangular perturbation iris is placed at 45° counterclockwise from the feeding slotline. A narrow slotline section (with dimension $2 \times .4$ mm) is used to connect the slot-ring and the iris. The split degenerate-modes are generated in the ring due to the perturbation, resulting in an RHCP of the antenna. The dimensions of the antenna are fine tuned to 2.4 GHz range. Due to the excessive transition loss of an SMA-slotline connection, a CPW-to-slotline transition [6] is adopted in the feed structure to integrate with an SMA connector. The transition loss for the suggested transition is less than 1 dB. The CPW is designed to 50 ohms. A radial-shaped iris at the end of the CPW will terminate the signal propagating in the right side slot of the CPW and transfer its power to the signaling slotline. The radiation slot-ring is coupled to a slotline by using a hairpin-slot coupling structure as shown in Fig. 1 [6]. This coupling mechanism is a current-coupling

type (also referred as a inductance coupling) which may have a wider bandwidth than a direct feed, and have a better frequency response than that of a capacitance coupling in higher frequency band. The CP performance is mainly determined by the perturbation-iris, although other parameters may contribute somewhat.

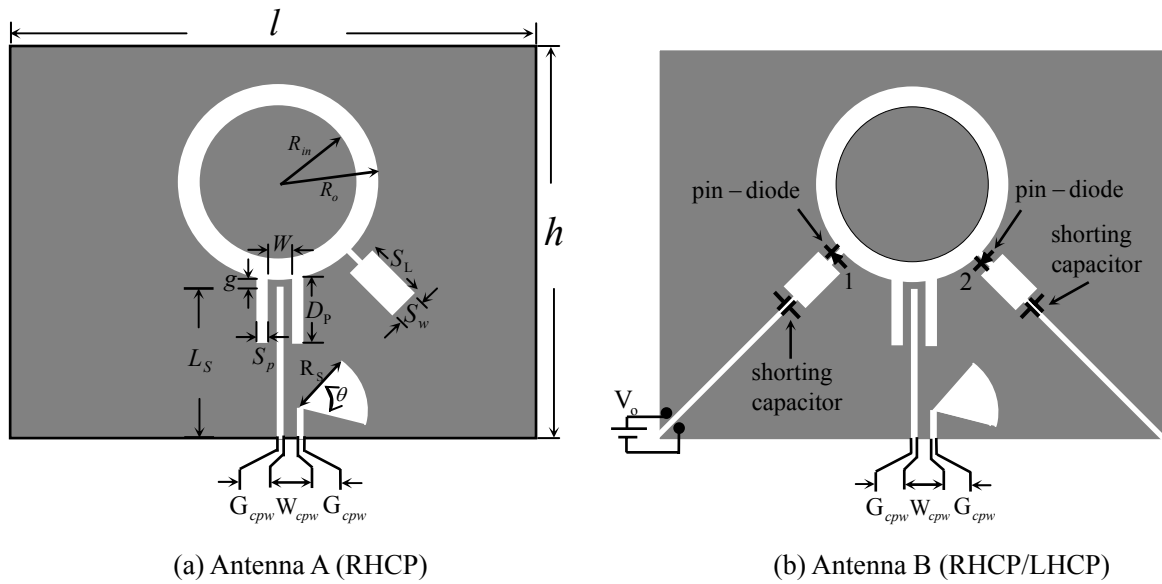

Fig. 1 The uniplanar slotline-feed CP slot-ring antenna structures for (a) antenna A and (b) antenna B.

In order to obtain a switchable CP property, the antenna denoted as antenna B shown in Fig. 1(b) is proposed. In contrast to antennas A, antenna B has two identical perturbation-irises located symmetrically with respect to the feed slotline. As shown in Fig. 1(b), a pin-diode (HPND-4038) is inserted in each connection slotline, and the ground plane is dc-wise separated into two parts using two thin slits. RF short in the ground plane is recovered by adding to each of the two slits a large capacitor. The dc-bias of the pin-diodes as shown in Fig. 1(b) determines the antenna’s polarization. An RHCP can be selected by assigning V_0 a negative voltage, and an LHCP can result from choosing a positive V_0 . Both antennas A and B are designed to exhibit circular polarization at 2.4 GHz.

3. Simulation and Sample Results

All the simulations were performed with Ansoft HFSS and Zeland IE3D. The shorting capacitors are emulated by metal-insulator-metal capacitors in the simulation, and the pin-diode ON state is represented by a 1.2 ohmic resistance and a capacitance of .12 pF is inserted for the replacement of a pin-diode OFF state.

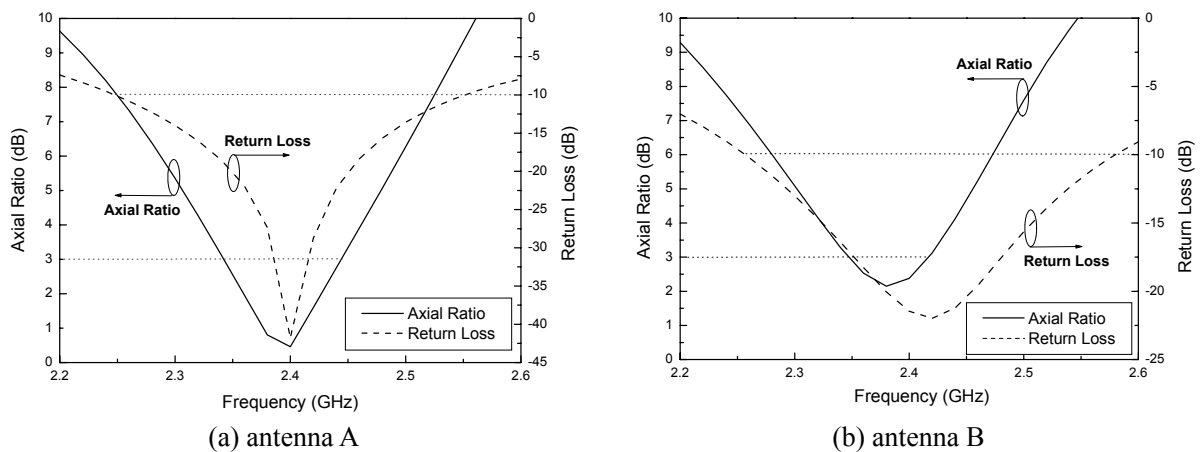

Fig. 2 The return losses and axial ratios for (a) antenna A and (b) antenna B

For antenna A, as shown in Fig. 2(a), the simulated axial-ratio bandwidth (ARB) is 4.3% and the minimum axial ratio (AR) is 0.46 dB at 2.4 GHz. The minimum return loss for antenna A is -47.8 dB occurred at 2.4 GHz and the -10 dB impedance bandwidth (BW) is 12.5%. In the case of antenna B, the achieved ARB is 2.9% and the minimum AR is 2.17 dB at 2.38 GHz, the obtained BW is 13.8%, and the minimum return loss is -22.3 dB at 2.417 GHz. The acquired performance for this antenna is sufficient to cover the entire ISM band. A slight discrepancy in the minimum axial ratios and ARBs for the minimum axial ratios and ARBs for antenna A and B is mainly due to the active device parameters. The antenna's radiation patterns are broadside and bi-directional, and the far field patterns in the X-Z ($\phi = 0^\circ$ plane) and Y-Z ($\phi = 90^\circ$ plane) planes for antenna A are given in Figs. 3(a) and 1(b), respectively. As shown in Fig. 3, the radiation patterns in these two planes are almost the same due to antenna's symmetric structure. The back-side radiation pattern is a mirror image of the front-side pattern, and the polarization senses of both sides are opposite to each other. The antenna radiates almost the same amount of energy into both sides. The simulated antenna gain is 3.03 dBi at 2.4 GHz, and the cross-polarization level is very high (larger than 30 dB in the broadside direction). Not shown in figure, the simulated cross-polarization-isolation of the antenna B (about 18 dB in the broadside) is inferior to that of antenna A, which is caused by the combination of dc-coupled effect and the parasitic parameters of the pin-diodes and the shorting capacitors.

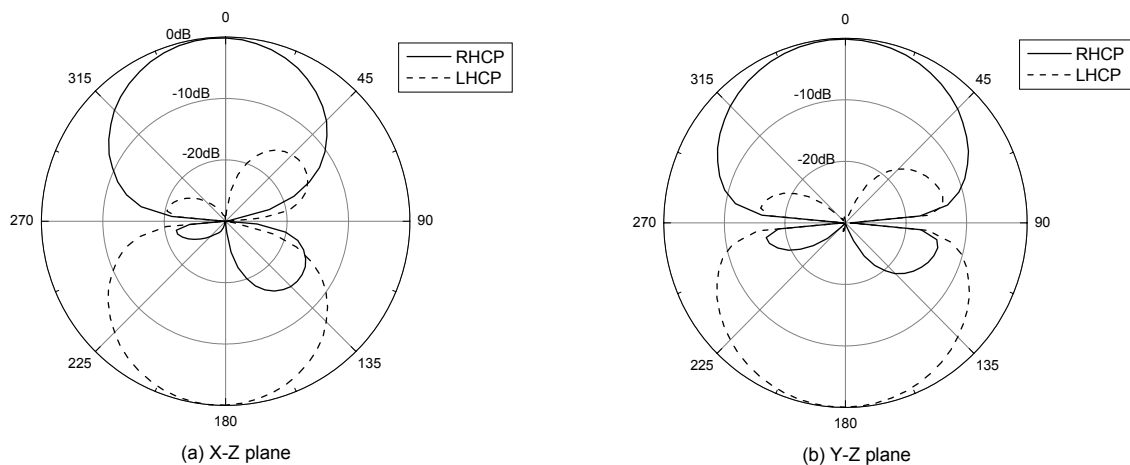

Fig. 3 The radiation patterns of antenna A in the (a) X-Z and (b) Y-Z planes.

4. Conclusion

A uniplanar printed slot-ring antenna configuration with a switchable circular-polarization sense at 2.4 GHz was presented in this paper. It has been shown that by controlling the bias voltage impressed on the two pin-diodes the polarization can be switched between RHCP and LHCP. The experimental measurements are still under process and will be presented later. This antenna design demonstrates a desirable feature for wireless communication applications such as WLAN, GPS, and satellite links. The uniplanar architecture of this antenna can alleviate the integration complexity of active elements and makes this antenna suitable for mass production. Furthermore, using FR4 substrate makes this antenna a low-cost one.

References:

- [1] S.-T. Fang, "A novel polarization diversity antenna for WLAN application," in *2000 IEEE AP-S Dig.*, July 2000. pp. 282-285.
- [2] Gui-Bin Hsieh, Ming-Huang Chen and Kin-Lu Wong, "Single-feed dual-band circularly polarized microstrip antenna," *Electron. Lett.*, Vol. 34, No. 12, pp. 1170-1171, June 1988.
- [3] M. Boti, L. Dussopt and J.-M. Laheurte, "Circularly polarized antenna with switchable polarization sense," *Electron. Lett.*, Vol. 36, No. 18, pp. 1518-1519, Aug. 2000.

- [4] Fan Yang and Y. Rahmat-Samii, "A reconfiguration patch antenna using switchable slots for circular polarization diversity," *IEEE Microwave and Wireless Components Letters*, Vol. 12, No. 3, pp. 96-98, Mar. 2002.
- [5] Mattias K. Fries, Mischa Gräni, and Rüdiger Vahldieck, "A reconfigurable slot antenna with switchable polarization," *IEEE Microwave and Wireless Components Letters*, Vol. 13, No. 11, pp. 490-492, Nov. 2003.
- [6] M.-H. Ho and C.-C. Chuang, "The uniplanar slotline-fed slot-ring dual-mode bandpass filter using hairpin-slot coupling," *Journal of the Chinese Institute of Electrical Engineering*, vol. 10, no. 4, pp. 407-412, Nov. 2003.