

IMPROVEMENT OF ARTIFICIAL DIELECTRIC RESONATOR AND ITS WAVEGUIDE FILTER APPLICATION

Achmad MUNIR, Atsushi SANADA, Hiroshi KUBO, and Ikuo AWAI
 Yamaguchi University, Electrical and Electronic Engineering
 2-16-1 Tokiwadai, Ube, Yamaguchi, 755-8611 Japan
 E-mail: munir@emlab.eee.yamaguchi-u.ac.jp

I. Introduction

It is hard to outline the history of the research on metamaterials due to the interdisciplinary nature of the field [1]. Not only the researchers in the microwave engineering but those from other disciplines like optics, physics, and chemistry, have published their results that have strong relevance to the microwave applications [2]-[6].

One of the metamaterials that was tried to use in microwave communication is artificial dielectrics. Actually, it was proposed more than five decades ago when Kock made a lens antenna by using the array of conducting wires [2]. Starting from the same concept, the present authors proposed a new application of artificial dielectrics to a microwave resonator of a reduced size by taking advantage of its possibly quite large permittivity for the first time [7]-[8]. It will realize a resonator of a reduced size by use of rectangular metal strips, and as a result, a bandpass filter. Though a miniaturized rectangular resonator and a waveguide bandpass filter were successfully demonstrated using anisotropic artificial dielectric materials [9], the relative permittivity and Q value of resonators were not high enough indicating the necessity of improvement.

In this paper, the improvement of an artificial dielectric resonator for gaining better characteristics e.g. higher relative permittivity and Q value, in a reduced thickness is investigated. The characteristics of an artificial dielectric resonator as a function of the rectangular metal strips length are analyzed. Hence, to effectuate the anisotropy of the resonator, the aspect ratio of rectangular metal strip length is made large enough. In this way, the anisotropy is used for discriminating the resonant modes aligning the anisotropy axis with the electric field of the desired mode. In fact, the anisotropy could be controlled beyond the possibility of crystallography, e.g. cylindrically or spherically anisotropic dielectric is possible.

At first, the principle of realizing the artificial dielectric with as high anisotropic permittivity as possible will be described briefly. Since the artificial dielectrics are assigned for exciting $TE_{10\delta}$ -mode, we have rectangular metal strips vertically aligned along the direction of the electric lines of force. Secondly, the analytical method of simulation by HFSS® version 8.0 is used for calculating the resonant frequency and Q value, which will be compared with the experimental result. In the last, to show the improvement result for a microwave application, a 2-stage miniaturized bandpass filter (BPF) in a rectangular waveguide is created.

II. Artificial Dielectric Rectangular Resonator

To obtain a resonator of high anisotropic permittivity, we employed a structure of the artificial dielectric resonator with each metal strip arranged in the face-centered orthorhombic lattice instead of simple orthorhombic structure, as shown in Fig. 1. The aligned metal strips polarize with the applied electric field and shows an effective dielectric constant macroscopically if the dimension of each metal strip or spacing between metal strips is small enough compared with the wavelength.

In the design of our artificial dielectric resonator, it is required that a material has a high permittivity in the y direction but low permittivity in the other directions. Thus, we have tried as long metal strips as possible to attain both. The material with a face-centered lattice of metal strip element as shown in Fig. 2 was fabricated. It consists of two layers of PCB (Printed Circuit Board) stacked each other with thickness of each layer (t_{PCB}) 0.5 mm and relative permittivity ($\epsilon_{\text{r-PCB}}$) 2.17. Each metal strip element has 0.5 mm of width w and horizontal gap between metal strips g_{h} , and 18 μm of thickness t being etched on a PCB. The rectangular metal strip length l and the vertical gap between metal strips g_{v} are changed at the same time, where l plus g_{v} is kept constant, to be 20 mm.

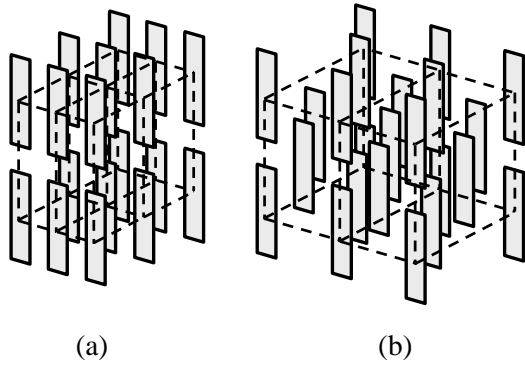

Fig. 1. Lattice alignment of metal element. (a) Simple orthorhombic. (b) Face-centered orthorhombic.

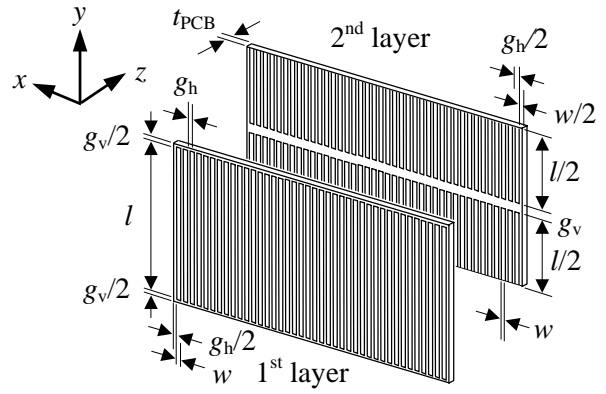

Fig. 2. Fabrication of artificial dielectric rectangular resonator. ($w = g_h = 0.5$ mm, $t = 18$ μm , $t_{\text{PCB}} = 0.5$ mm, and $\epsilon_{\text{r-PCB}} = 2.17$).

III. Simulation and Experimental Set-Up

A. Resonant Frequency and Q Value

To demonstrate a potential improvement of characteristics of the artificial dielectric rectangular resonator, we fabricated an artificial dielectric rectangular resonator depicted in Fig. 2, piling up the etched PCBs one another with a quasi-face-centered lattice structure for attaining a large effective permittivity as mentioned before. The measurement of the resonant frequency and Q value as a function of the vertical gap between metal strips g_v for the $\text{TE}_{10\delta}$ -mode were carried out using a WRJ-6 type rectangular waveguide. Since the cut off frequency of the waveguide is 3.75 GHz, the lower frequency resonant waves are evanescent outside of the resonator. Hence, the waveguide ends were left open keeping enough length from the resonator. The excitation of $\text{TE}_{10\delta}$ -mode is made by a metal probe extending from the SMA connector center pin with the probe length of 15 mm, and the probe thickness of 1.0 mm.

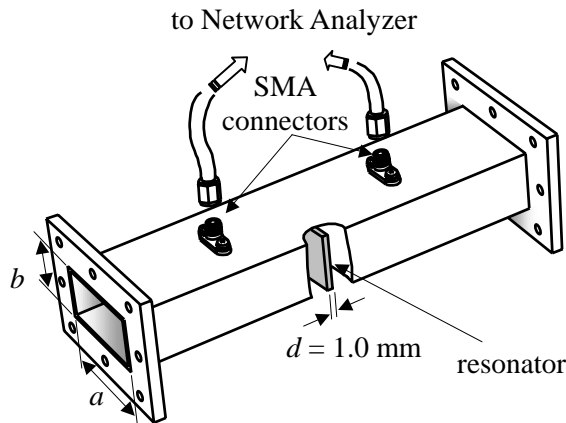

Fig. 3. Experimental set-up for the measurement of resonant frequency and unloaded Q . ($a = 40$ mm and $b = 20$ mm).

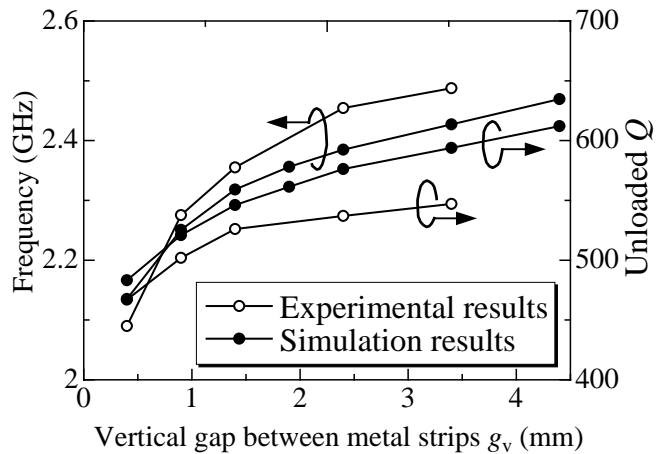

Fig. 4. Resonant frequency and unloaded Q value of artificial dielectric resonator as a function of vertical gap between rectangular metal strips g_v for the $\text{TE}_{10\delta}$ -mode.

The HFSS® simulation results of resonant frequency and unloaded Q value as a function of the vertical gap between metal strips g_v are depicted in Fig. 4. For comparison, the experimental results are also plotted in the same figure. The Q value indicates a good stability for both results and they show a good agreement qualitatively. By employing the equations in [9] the relative permittivity (ϵ_r) of resonators can be calculated. The calculation results for both simulation and experimental values are plotted in Fig. 5 giving a reasonable agreement. Since the used resonator is thin enough to

be fabricated by stack of only two PCB layers, the shield effect of metal strips on each layer that hampers the electromagnetic wave propagation decreases, resulting in a higher relative permittivity. Though the figure shows the improvement, this was not so high as was expected, which was possibly evoked by inevitable gaps or insufficient contact between rectangular metal strips and the horizontal waveguide inner-wall due to the poor fabrication techniques of the resonators.

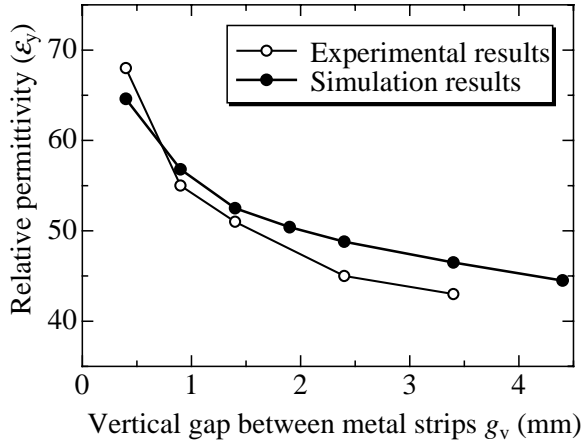

Fig. 5. Relative permittivity of artificial dielectric resonator as a function of the vertical gap between rectangular metal strips g_v for the $TE_{10\delta}$ -mode.

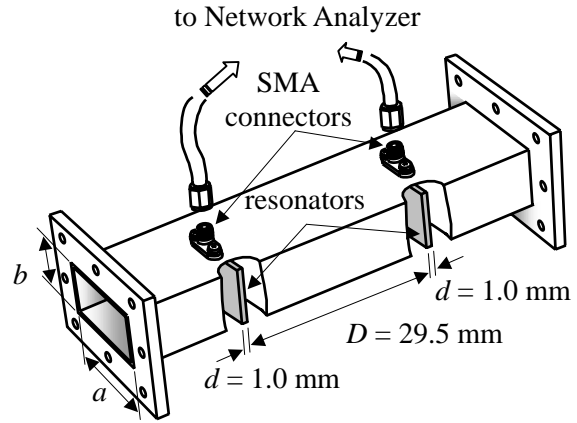

Fig. 6. Experimental set-up for the measurement of characteristics of a waveguide bandpass filter. ($a = 40$ mm and $b = 20$ mm).

B. Two-stage Bandpass Filter

To show feasibility of improved artificial dielectric resonators for a microwave application, we have created a 2-stage miniaturized BPF of the artificial dielectric rectangular resonators that have the vertical gap between metal strips g_v 0.4 mm encapsulated in a metal waveguide, as shown in Fig. 6. The distance D between two resonators is 29.5 mm and the thickness d of resonators d is 1.0 mm where this thickness is one-tenth of the resonator thickness used for the same bandpass filter in [9]. To obtain a good bandpass filter characteristic, a probe with the length of 15 mm and the thickness of 1.0 mm was taken. Due to the hand-made resonators, the insertion loss in Fig. 7 is rather high, but it still shows a good bandpass characteristic. The spurious characteristics in Fig. 8 show TE_{20d} mode around 3GHz, which could be removed by inhomogeneous arrangement of metal strips [10]. The measured center frequency, bandwidth, and insertion loss are 1.942 GHz, 253 MHz, and 0.22 dB, respectively. From the figure, we have calculated the unloaded Q value of each resonator as around 429 where this value is around 30% higher than the result in [9].

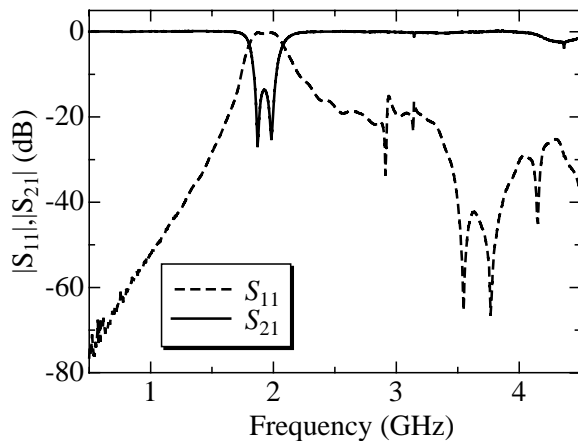

Fig. 7. Spurious property of 2-stage waveguide bandpass filter.

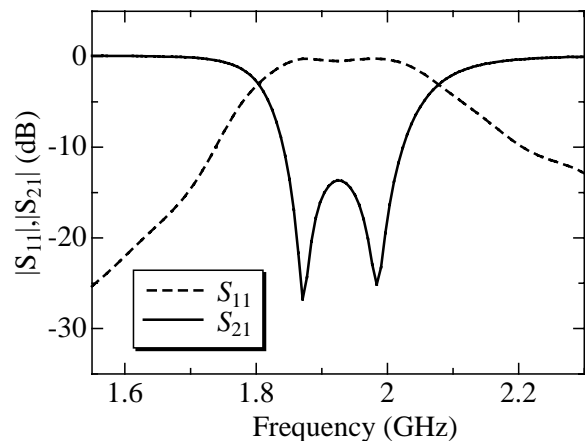

Fig. 8. Narrow range frequency of 2-stage waveguide bandpass filter.

IV. Conclusion

The improvement of a dielectric resonator made of anisotropic artificial dielectric material has been investigated. Though the relative permittivity was not so high as was expected, in general the results have shown an improvement especially for the reducing thickness of resonator. To demonstrate feasibility of the improvement for a microwave application, a two-stage waveguide BPF made of improved artificial dielectric resonators that is encapsulated in a metal waveguide are well-suited for miniaturization and its properties have been measured to show good spurious characteristics, where the measured result indicates an improvement of Q value and bandwidth. More investigation for obtaining a higher anisotropic permittivity is under way by attaining the enough contact between rectangular metal strips and the horizontal waveguide inner-wall. If it can be realized, an increase of the relative permittivity by more than 5 times is expected.

V. References

- [1] R. E. Collin, "Field theory of guided waves", IEEE Press, second edition, pp. 749-786, 1991.
- [2] W. E. Kock, "Metallic delay lenses," Bell Syst. Tech. J. vol. 27, pp. 58-82, 1948.
- [3] M. M. I. Saadoun and N. Engheta, " A reciprocal phase shifter using novel pseudo chiral or Ω medium", Microwave and Optical Tech. Lett., Vol.5, No.4, pp.184-188, 1992.
- [4] M. Tanaka and K. Sato, "Transmission and reflection characteristics of a multilayered chiral slab", IEICE Trans. Electron. Vol.J75-C-I, No.10, pp.677-680, 1992.
- [5] I. V. Lindell, A. H. Sihvola, S. A. Tretyakov and A. J. Vitanen, "Electromagnetic waves in chiral and bi-isotropic media," Artech House, Inc. 1994.
- [6] F. Wu, K. W. Whites, "Quasi-static effective permittivity of periodic composites containing complex shaped dielectric particles," IEEE Trans. Antenna
- [7] I. Awai, H. Kubo, T. Iribe, and A. Sanada, "Dielectric resonator based on artificial dielectrics and its application to a microwave BPF," in 32nd European Microwave Conference Proc., pp. 1045–1048, Sept. 2002.
- [8] H. Kubo, T. Iribe, A. Sanada and I. Awai, "An artificial dielectric composed of metal strips and evaluation of its permittivity and loss", in 2002 Asia-Pacific Microwave Conference Proc., pp. 1588–1591, Nov. 2002.
- [9] I. Awai, A. Munir, N. Hamanaga, H. Kubo, and A. Sanada, "Artificial dielectric rectangular resonator with great anisotropic permittivity and its waveguide application", in 2003 Asia-Pacific Microwave Conference Proc., pp. 1752–1755, Nov. 2003.
- [10] A. Munir, N. Hamanaga, H. Kubo, and A. Sanada, and I. Awai, "Improvement of spurious property of waveguide bandpass filter based on artificial dielectrics," submitted for the 34th European Microwave Conference Proc., Oct. 2004.