

ANALYSIS OF MULTIPLE TRANSVERSE AND LONGITUDINAL SLOTS IN A WAVEGUIDE BY THE SPECTRUM OF TWO-DIMENSIONAL SOLUTIONS METHOD

John YOUNG, Jiro HIROKAWA, and Makoto ANDO
Dept. of Electronic and Electronic Eng., Tokyo Institute of Technology,
2-12-1, O-okayama, Meguro-ku, Tokyo, 152-8552, Japan
johny@antenna.ee.titech.ac.jp

I. Introduction

A cylindrical waveguide with slots incised into the waveguide wall is often used as a base station antenna in a mobile communications system. For example, rectangular, circular, and triangular waveguides are commonly used in these types of systems. Many analyses of these types of structures assumes that the waveguide is infinite in extent and that the exterior structure of the waveguide is replaced with an infinite ground plane. These approximations are often good ones to determine parameters such as the reflection and transmission in the waveguide, however for some applications they may not be accurate enough. Furthermore, for some parameters, such as radiation patterns, the geometry of the external structure may have a significant impact. Also, the analysis of the waveguide interior is often limited to canonical structures for which Green's functions can be derived. For example, the triangular waveguide mentioned above is often approximated by a sectoral waveguide so that a Green's function in the interior region can be derived. In addition, the ground plane approximation is difficult to apply when slots are cut across more than one waveguide wall or when different slots are on different waveguide walls. For other structures, techniques other than the traditional ones are needed. One method that has gained in popularity recently is the Spectrum of Two-Dimensional Solutions (S2DS) method [1],[2]. With the S2DS method, one is able to dispense with the infinite ground plane assumption for the external structure and to incorporate the actual cross-section of the waveguide into the solution. The waveguide is still assumed to be infinite in length though. In addition, the method may also be applied to the interior region of the structure, and, hence, the restriction to canonical structures is removed. In this paper, a rectangular waveguide with multiple transverse or longitudinal slots is analyzed by the S2DS method. The slots are excited by a TE₁₀ mode that propagates inside the waveguide. Results are presented for the transmission and reflection coefficients in the waveguide.

II. Spectrum of Two-Dimensional Solutions Method

The S2DS method has been studied by a number of researchers. In this method, one formulates an integral equation in the spatial domain for the unknown currents on the slots by shorting the slots and placing equivalent magnetic currents on the shorted slots to support the original fields. Because the Green's functions for a magnetic dipole radiating in the presence of the structure may not be known, the scattering structure is also removed and replaced with an equivalent current. Since the additional equivalent surface is infinite in extent, the integral equation that results is difficult to solve in the spatial domain. Therefore, the reactions that determine the individual matrix elements in the original equation are computed in the spectral domain, which requires the calculation of an inverse Fourier transform. Hence, an additional integral equation must be solved in the spectral domain for the induced current on the surface of the scattering structure for a large number of spectral frequencies. To speed the convergence of the Fourier integral, the asymptotic behavior of the scatterer current near the slots that is induced by a particular slot current may be identified with that of the current induced on an infinite ground plane by the same slot current [3]. An additional advantage of the S2DS is that the radiation pattern of the structure may be computed easily from the spectral currents [4]. This is important because even though parameters such as reflection coefficients, transmission coefficients, and aperture admittances can be calculated fairly accurately by use of the external ground plane approximation, the radiation pattern is sensitive to the actual

external structure. To compute the results presented in this paper, the slot currents are expanded and tested with piecewise-linear basis functions, and a magnetic field integral equation is solved in the spectral domain for the spectral scatterer currents, which are expanded and tested with pulse basis functions. The effects of the wall thickness region are also included in the formulation

III. Results

The reflection and transmission coefficients for a structure comprising slots cut in the broad wall of a rectangular waveguide are presented. Both the interior and exterior structures are analyzed with the S2DS method, and the effect of the wall thickness is included. The rectangular waveguide is a standard x-band waveguide, and the dimensions of the slots and waveguide are given in Fig. 1 and Fig. 2 for the longitudinal slot structure and the transverse slot structure, respectively. All slots have a constant width of 1.6 mm. For each structure, data is given for both a waveguide with one slot and a waveguide with two slots. Also, for comparison, results for the case that the waveguide is embedded in an infinite ground plane are given. The results for the full structure are indicated by RWG (rectangular waveguide) and the results for the infinite ground plane case are indicated by GP (ground plane). In Fig. 4 and Fig. 5 are presented the magnitude and phase of the reflection coefficient for the longitudinal slot structure, and in Fig. 5 and Fig. 6 are presented the magnitude and phase of the transmission coefficient for the same structure. In each plot, data is given both for a single slot and for two slots. For the case of the structure with one longitudinal slot, the slot offset p is 8 mm. For longitudinal slots, when the actual external structure is used the resonant frequency shifts slightly downward over that of the infinite ground plane case. Furthermore, the magnitude of the reflection coefficient for the full structure is slightly different than that of the ground plane structure. In Fig. 7 and Fig. 8 are plotted the magnitude and phase of the reflection coefficient for a waveguide with transverse slots, and in Fig. 9 and Fig. 10 are plotted the magnitude and phase of the transmission coefficient for the same structure. The addition of the second slot creates a reflection canceling effect around 8.4 GHz. The slot pair radiates more energy than a single slot, but the phase of the slot pair is seen to be more frequency sensitive. For the transverse slot structure, the data for the full structure and the data for the ground plane structure are nearly identical. Thus, for transverse slots, the external ground plane approximation is seen to be very good.

IV. Conclusions

A slotted, rectangular waveguide excited by a TE₁₀ wave is analyzed by the Spectrum of Two-Dimensional Solutions method, and the wall thickness effects are included. With this method, the full structure is accounted for. Transmission and reflection coefficients are presented for a structure with transverse slots and for a structure with longitudinal slots. Comparisons are made between the full analysis and that where the external structure is replaced by an infinite ground plane. The external ground plane approximation is seen to be very good for a structure with transverse slots, but some change in the data is observed for the two structures with longitudinal slots. The S2DS method is easily extended to account for waveguides with more arbitrary cross-sections. Furthermore, when combined with an FEM solution for the wall thickness region, it is capable of accurately analyzing structures with slots that extend across multiple waveguide walls.

V. References

- [1] A. F. Peterson and R. Mittra, "Mutual admittance between slots in cylinders of arbitrary shape," *IEEE Trans. Antennas Propagat.*, vol. 37, pp. 858-864, July 1989.
- [2] K. Forooghi, P. Kildal, and S. R. Rengarajan, "Admittance of an isolated waveguide-fed slot radiating between baffles using a spectrum of two-dimensional solutions," *IEEE Trans. Antennas Propagat.*, vol. 41, pp. 422-428, April 1993.
- [3] J. Wettergren and P.S. Kildal, "Admittance of a longitudinal waveguide slot radiating into an arbitrary cylindrical structure," *IEEE Trans. Antennas Propagat.*, vol. 43, pp. 667-673, July 1995.
- [4] P.S. Kildal, S. Rengarajan, and A. Moldsvor "Analysis of nearly cylindrical antennas and scattering problems using a spectrum of two-dimensional solutions," *IEEE Trans. Antennas Propagat.*, vol. 44, pp. 1183-1192, August 1996.

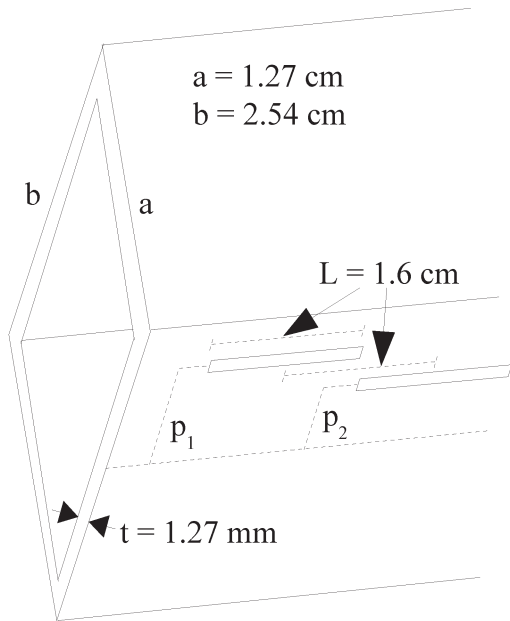

Figure 1. Longitudinal slot structure, ($p_1=8\text{mm}$, $p_2=5\text{mm}$).

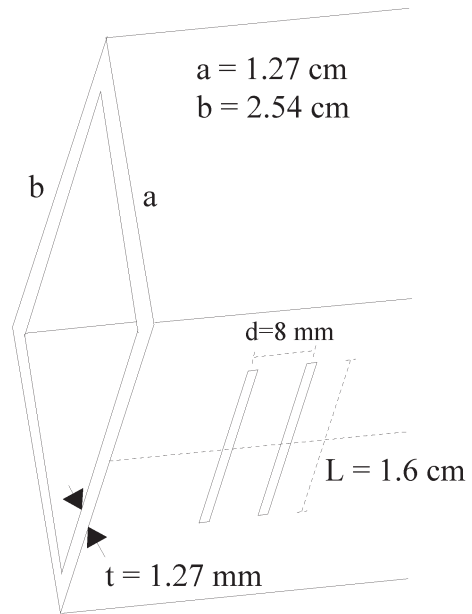

Figure 2. Transverse slot structure.

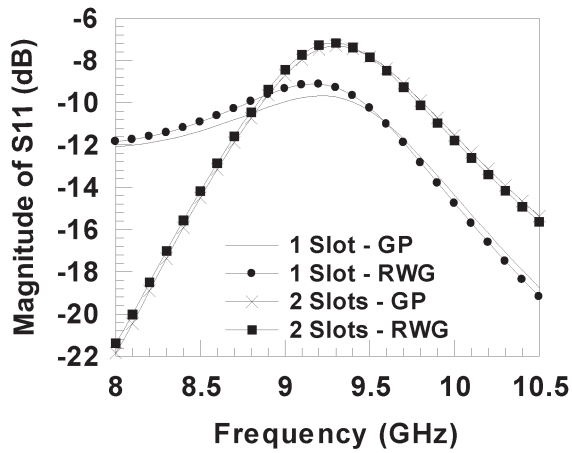

Figure 3. Magnitude of reflection coefficient for longitudinal slots in a rectangular waveguide.

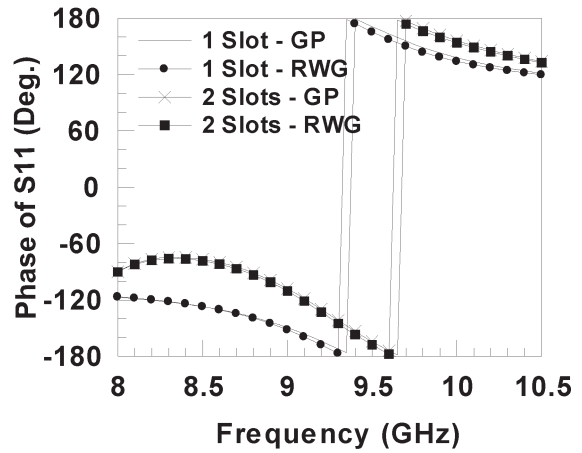

Figure 4. Phase of reflection coefficient for longitudinal slots in a rectangular waveguide.

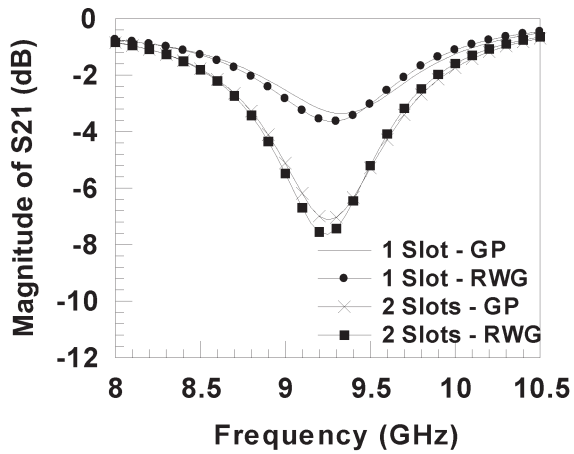

Figure 5. Magnitude of transmission coefficient for longitudinal slots in a rectangular waveguide.

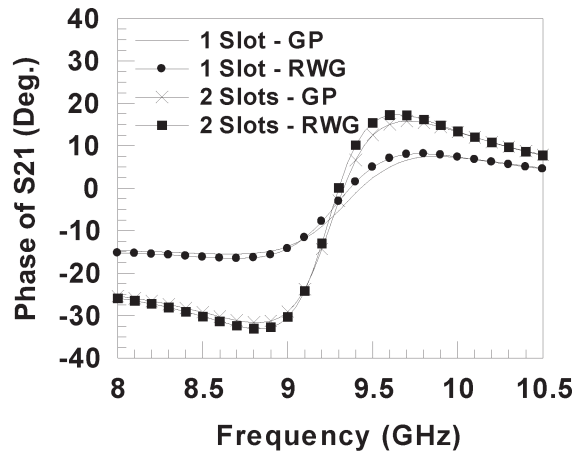

Figure 6. Phase of transmission coefficient for longitudinal slots in a rectangular waveguide.

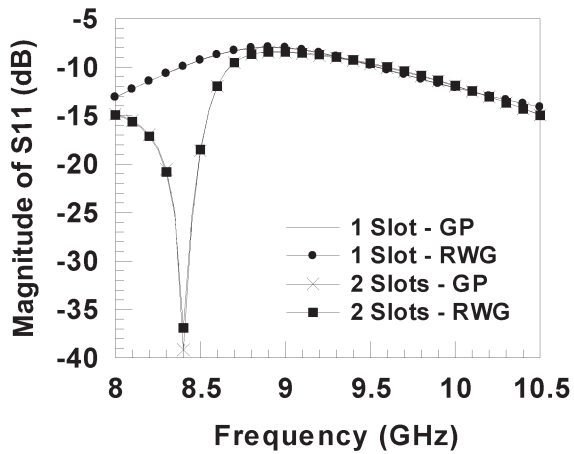

Figure 7. Magnitude of reflection coefficient for transverse slots in a rectangular waveguide.

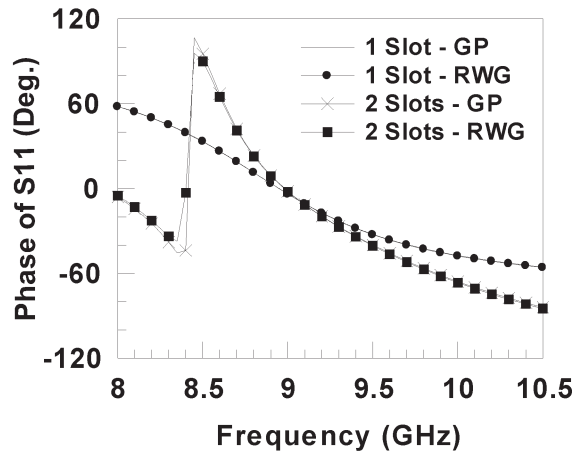

Figure 8. Phase of reflection coefficient for transverse slots in a rectangular waveguide.

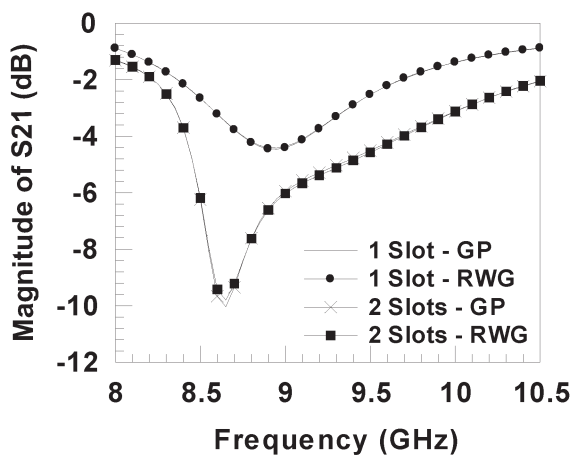

Figure 9. Magnitude of transmission coefficient for transverse slots in a rectangular waveguide.

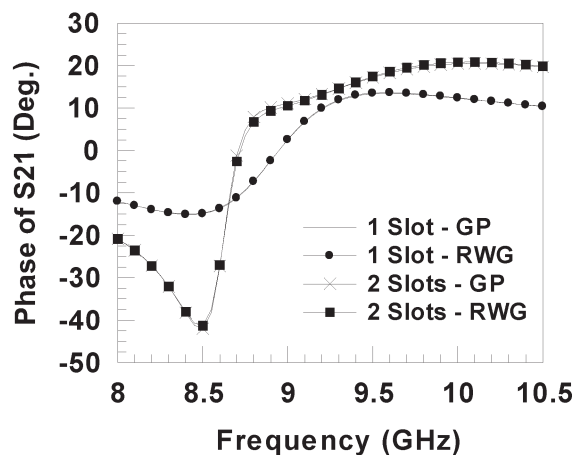

Figure 10. Phase of transmission coefficient for transverse slots in a rectangular waveguide.