

Phased Array Calibration Method with Evaluating Phase Shifter Error

Nobuyasu TAKEMURA, Hiroyuki DEGUCHI, Rumiko YONEZAWA and Isamu CHIBA
Mitsubishi Electric Corporation
5-1-1, Ohfuna, Kamakura, Kanagawa, 247-8501, Japan
takemura@isl.melco.co.jp

1. Introduction

The rotating-element electric-field vector (REV) method [1] is used to determine/adjust amplitude and phase value of element antennas in an array environment [2]. Effect due to both deviation of phase shifters and power stability reduces the measuring accuracy because the conventional REV method introduces assumption that the composite power sinusoidally varies according to modifications of each phase shifter [3]. To achieve precise calibration for phased array antennas, we propose a new measurement method taking for account both the variation of the rotating vector and the phase shifter error. In this paper, the measurement theory and procedure of the proposed method are described, and then the validity is confirmed by the simulation results with the phase shifter error.

2. Theory and procedure of measurement method

In the REV method, we can determine the relative amplitude/phase of the elements by measuring the maximum and minimum power ratio of the composite power and the phase that provides maximum power. Fig. 1 shows the configuration of a phased array used as a transmit antenna. The composite field vector is a superposition of the field vectors of the elements in a specific direction. The sinusoidal variation of the composite power by the phase change of an element is shown in Fig. 2. The phase shifter error, reappearance error etc. are included to measurement value. Most of the errors cause by the phase shifter. In the conventional REV method, we can not evaluate the phase shifter error that is caused by changing the phase of each element by the phase shifter.

The rotating element field vector with the phase shifter error is shown in Fig. 3, where \dot{E} is the composite field, \dot{A}'_m is the phase shifter error, \dot{C}'_n is the evaluation field without the phase shifter error and $\dot{C}'_n(\Delta_m)$ is the evaluation field with the phase shifter error. The composite power is varied in the condition that the phase shifter error is included by the phase change of an element. Here, by the method of least squares, we decide the phase shifter error \dot{A}'_m and the composite field $\dot{E}'_{n,off}$ other than the n th element such as follows.

$$\frac{\partial(\sigma^2)}{\partial \dot{A}'_{m*}} = 0 \quad , \quad \frac{\partial(\sigma_A^2)}{\partial \dot{E}'_{n,off*}} = 0 \quad (1)$$

where the dot (·) is the complex, the dash (˘) is the evaluation value, the asterisk (*) is the

conjugate, σ^2 is the average of the square sum of the difference between the measured field and evaluation field $\dot{C}_n(\Delta_m)$ with the phase shifter error, σ_A^2 is the average of the square sum of the error \dot{A}'_m and m corresponds to the change of the phase, $m=1,2,\dots,M$. The average of the phase shifter error \dot{A}'_m is 0. In this way, the evaluation field $\dot{C}_n(\Delta_m)$ that considered the error \dot{A}'_m is as follows, when the phase of the phase shifter that is connected to the n th element is changed only phase Δ_m .

$$\dot{C}_n(\Delta_m) = \dot{C}'_n(1 + \dot{A}'_m) = \left(\bar{E}_m - \frac{1}{M} \sum_m \bar{E}_m \right) e^{-j\Delta_m} \quad (4)$$

At this time, the average σ_A^2 of the square sum of the error \dot{A}'_m is as follows.

$$\sigma_A^2 = \frac{1}{|\dot{C}'_n|^2} \left\{ \frac{1}{M} \sum_m |\bar{E}_m|^2 - \left| \frac{1}{M} \sum_m \bar{E}_m \right|^2 - |\dot{C}'_n|^2 \right\} \quad (5)$$

with

$$\dot{C}'_n = \frac{1}{M} \sum_m \bar{E}_m e^{-j\Delta_m} \quad (6)$$

where the bar () is the average, n corresponds to the n th element, $n=1,2,\dots,N$, and \bar{E}_m is the average of the measured composite field by the implementation of the i times in phase Δ_m of the phase shifter that is connected to the n th element. We can determine the evaluation field $\dot{C}_n(\Delta_m)$ with the phase shifter error \dot{A}'_m of the element by using (3) ~ (6), from the average \bar{E}_m of the measured composite field.

3. Simulation with the phase shifter error

We simulated such that measured the variation of the composite field and evaluated the error at the time of the phase change by the phase shifter, where frequency is 2.5GHz, the element number is 31, the phase shifter is 5bit. In the case that it made the implementation number by REV method 1 time, the phase shifter error made that the average is 0, r.m.s. is 0.05+j0.05. The comparison of the element field vector with the phase shifter error is shown in Fig. 4. In the same figure, (a) shows amplitude, (b) shows phase. The solid line is the actually gave value, point chain line is the evaluation value by conventional REV method, dotted lines are the evaluation values \dot{C}'_n , $\dot{C}_n(\Delta_m)$. It understands that the evaluation field of the element that evaluated from the measured composite field agrees well with the field of the element including the phase shifter error. In Fig. 5 it is shown that the comparison of the difference between the evaluation field of the element determined by conventional REV method and the field of the element that is shown in the evaluation value \dot{C}'_n . In the same figure, (a) shows amplitude, (b) shows phase. In this way, it is conceivable that the evaluation field of the element that is shown to the evaluation value \dot{C}'_n is able to evaluate the field of the element without the error, when we see it generally.

4. Conclusion

We propose a new measurement method by which amplitude/phase deviation in operation can be detected. And it showed that were able to evaluate the amplitude and

phase value of the element to high accuracy, by considering the influence of the phase shifter error, in the REV method that used the amplitude and phase value of the composite field.

References

- [1] S.Mano, T.Katagi, "A Method for Measuring Amplitude and Phase of Each Radiation Element of a Phased Array Antenna," Trans. IECE, Vol.J65-B, No.5, pp.555-560 (1982)
- [2] R.Yonezawa et al., "Beam-Shape Correction in Deployable Phased Arrays," IEEE Trans., Vol.47, No.3, pp.482-486 (1999)
- [3] R.Yonezawa et al., "Radiation between Errors of Phase Shifter and Measurement Errors of the Rotating Element-Field Vector Method," IEICE, AP92-75 (1992)

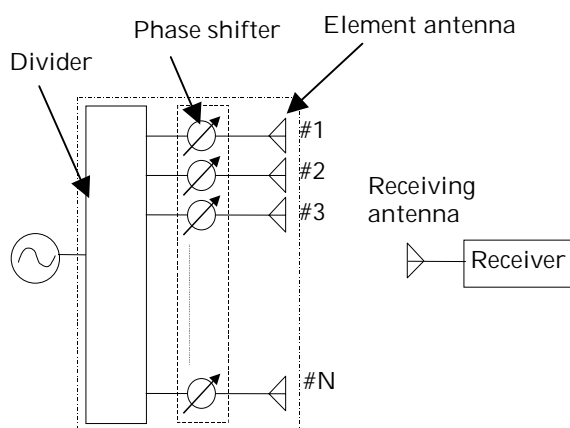

Fig. 1. Configuration example of a phased array antenna.

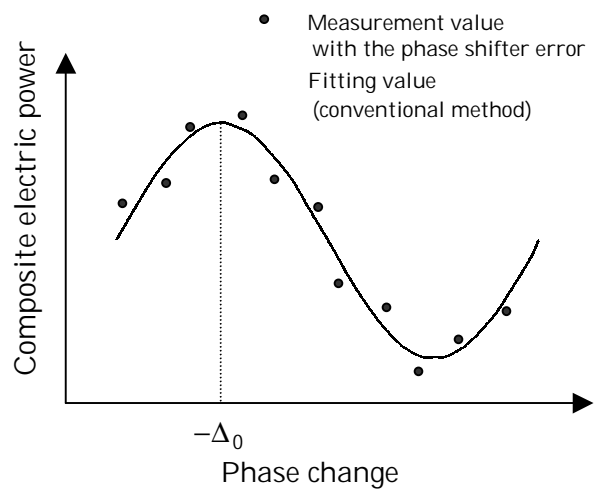

Fig. 2. Relation of phase change and composite power.

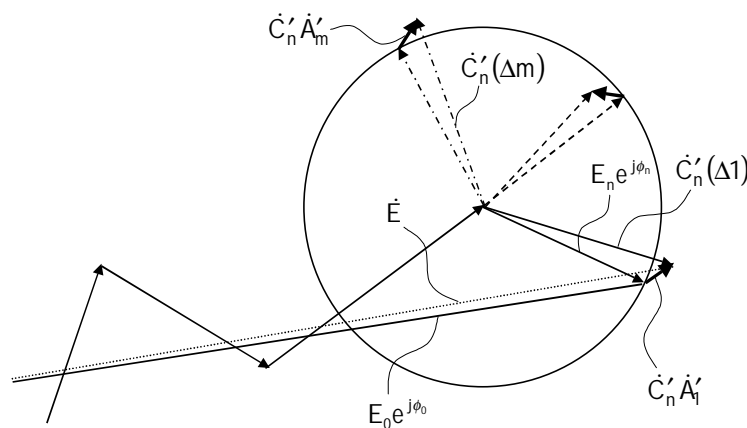
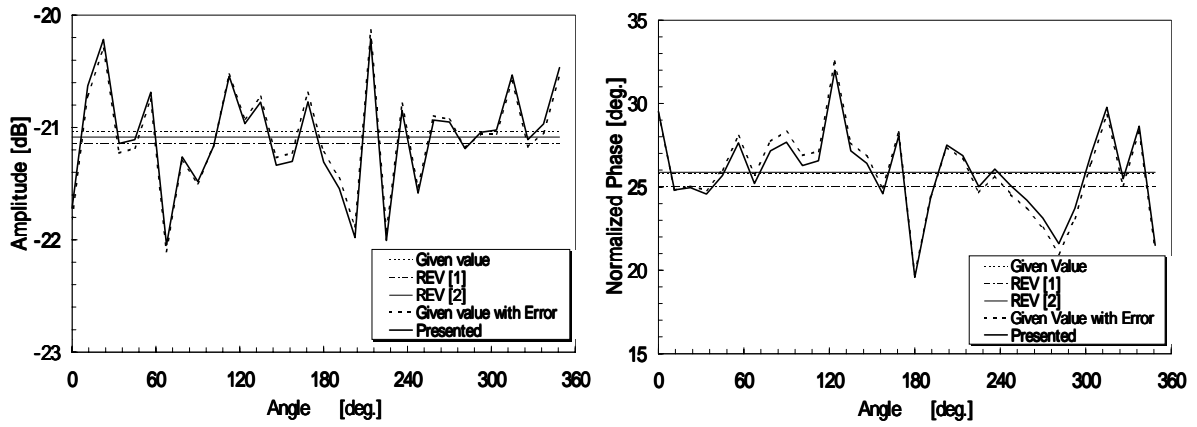
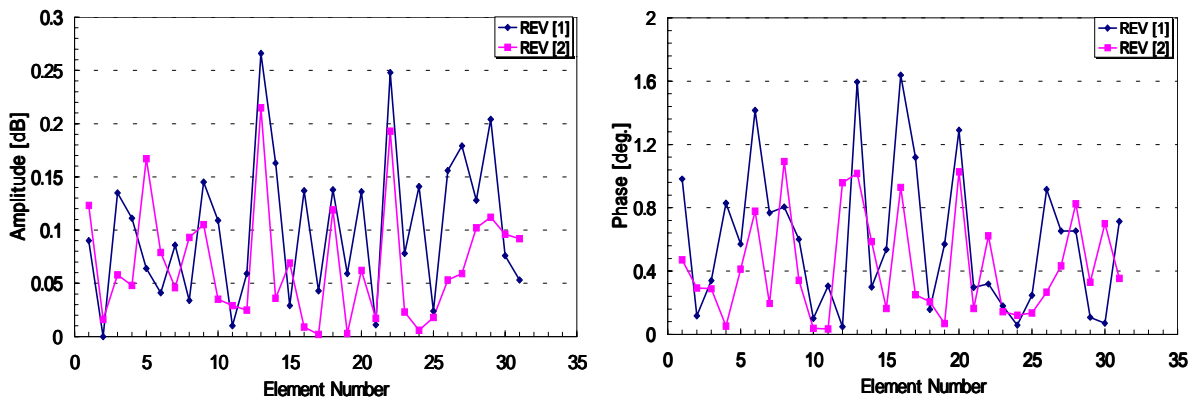

Fig. 3. Rotating element field vector with phase shifter error, where \hat{A}'_m is the phase shifter error and $\hat{C}'_n(\Delta_m)$ is the evaluation field with the error \hat{A}'_m of the n th element.



(a) Amplitude (b) Phase

Fig. 4. Comparison of the element field vector (No.4) with the phase shifter error. (a) shows amplitude, (b) shows phase. The solid line is the actually gave value, point chain line is the evaluation value by conventional REV, dotted line is the evaluation value \hat{C}'_n without phase shifter error, $\hat{C}_n(\Delta_m)$ with phase shifter error.



(a) Amplitude (b) Phase

Fig. 5. Comparison of the difference between the evaluation field of the element determined by conventional REV and the field of the element that is shown in the evaluation value \hat{C}'_n without phase shifter error. (a) shows amplitude, (b) shows phase.