

Design of Planar Antenna for Small Implantable Devices

#Kohei Kawasaki¹, Masaharu Takahashi², Kazuyuki Saito², Koichi Ito¹

¹Graduate school of Engineering, Chiba University

1-33 Yayoi-cho, Inage-ku, Chiba 263-8522, Japan, #k.kawasaki@chiba-u.jp

²Research Center for Frontier Medical Engineering, Chiba University
1-33 Yayoi-cho, Inage-ku, Chiba 263-8522, Japan

1. Introduction

Recently, small implanted devices have been investigated with great interest for wireless communication tools. Especially, the devices are expected to apply for medical field in order to improve quality of life (QOL) of patients [1], [2]. In these systems, an antenna which mounted in the devices, implanted antenna, plays important role as a part of transmitting and receiving power. Therefore, the research on the antenna is very important for developing the implantable devices. In this report, an implanted antenna for monitoring of biological information is proposed. The antenna element has planar structure and can match an integrated circuit (IC) chip. The operating frequency is 2.45 GHz, one of the industrial-scientific-medical (ISM) bands. The input impedance and the radiation pattern of the antenna are analyzed by use of finite-difference time-domain (FDTD) method.

2. Link Budget for Wireless Communication

In this report, the proposed antenna is assumed to be used in a room for medical data transmission. Therefore, it is necessary to know some key parameters related to a link budget for communications between the implanted antenna and the receiver. The operating frequency is set to 2.45 GHz and input power to the implanted antenna is 25 μ W [3]. The receiving antenna is assumed to be a monopole antenna. The required Rx power (RP) is calculated from the following equation:

$$RP = E_b/N_0 + kT_0 + B_r \text{ [dBW]} \quad (1)$$

Where E_b/N_0 is the ideal-PSK [dB], k is the boltzmann constant [J/K], T_0 is the ambient temperature [K], B_r is the required bit rate [kbps]. The available Rx power (AP) is calculated from the following equation:

$$AR = P_t + G_t + G_r - L_f \text{ [dBW]} \quad (2)$$

Where P_t is the required power of implanted antenna [dBW], G_t is the gain of the implanted antenna [dBi], G_r is the gain of the receiving antenna [dBi], L_f is free space path loss [dB]. Here, it is supposed to be $B_r = 10.0$ kbps, $L_f = 52.3$ dB. If the AP is larger than RP by 20 dB, the wireless communication between implanted antenna and external equipments will be possible. If the gain of the proposed antenna is more than -18.0 dBi, the margin is exceeds 40 dB. This result is enough to communicate between the implanted antenna and an external equipment. So, in this report, communication will be made possible if the gain of proposed antenna is -18.0 dBi.

3. Antenna Structure and Calculation Model

The antenna structure is shown in Figure 1. The antenna element has planar structure and the length is 15.0 mm. In addition, the antenna is provided a shorting-pin because of matching an IC chip. The implanted device is supposed to be inserted into human body using a syringe. In order to satisfy this requirement, the device is simulated glass ($\epsilon_r = 5.0$) which has a cylindrical shape of 1.2

mm diameter and 16.0 mm length and the antenna element is buried into this glass. The impedance of IC chip is set to be $9.3 - 55.2 \Omega$ [4] and operating frequency is 2.45 GHz.

Figure 2 shows numerical calculation model. The dimensions of the model are $60 \times 60 \times 60 \text{ mm}^3$. This phantom is simulated a surface of human arm and consists of three different tissues, dry skin, fat, and muscle. The thickness of each is 2 mm, 4 mm, and 54 mm. The electrical properties are defined as the value of each tissue at 2.45 GHz (skin: $\epsilon_r = 38.0$, $\sigma = 1.5 \text{ S/m}$, fat: $\epsilon_r = 5.3$, $\sigma = 0.1 \text{ S/m}$, muscle: $\epsilon_r = 52.7$, $\sigma = 1.7 \text{ S/m}$). The proposed antenna is buried into the fat layer, and positioned just beneath the skin layer. In this condition, the antenna characteristics of input impedance and radiation pattern are analyzed by use of FDTD method.

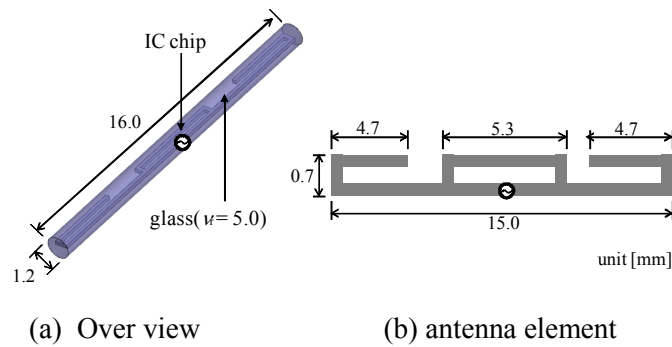

Figure 1 : Antenna structure

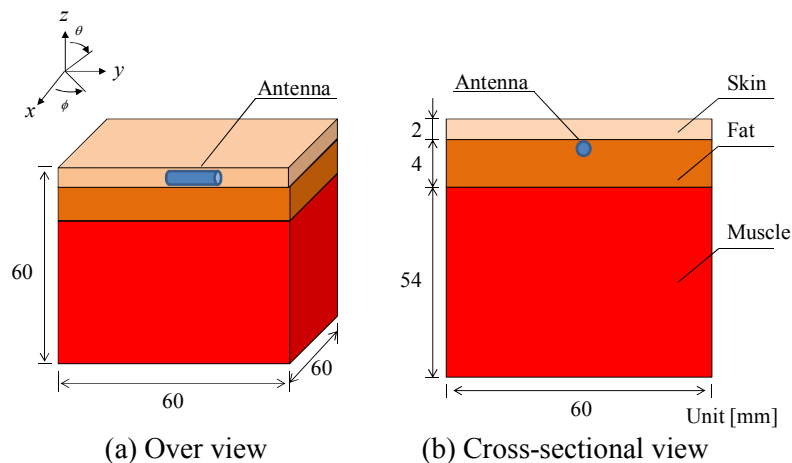

Figure 2 : Numerical calculation model

4. Calculation Results

Figure 3 shows calculated reflection coefficient of the proposed antenna. This result is standardized by the impedance of the IC chip. From the result, the reflection coefficient at 2.45 GHz is -15.3 dB. In addition, the proposed antenna can match an IC chip when the antenna is buried into rectangle model. Figure 4 shows radiation pattern in the x - z and y - z planes when the antenna is embedded into the calculation model. It is important to radiate radio waves pass through the skin because there is external equipment in that direction. Therefore, the gain of $+z$ direction is important. It is found that the directions of maximum radiation of calculated results in both planes are $+z$ direction. The maximum gain both in the x - z and y - z planes is -13.0 dBi. According to the link budget for wireless communications, if the gain of the antenna is more than 18.0 dBi, the antenna can communicate with the external equipment. From the above, the calculated result of the antenna is higher than this target centered at $+z$ in both planes and it is found that the antenna can be available for implantable devices.

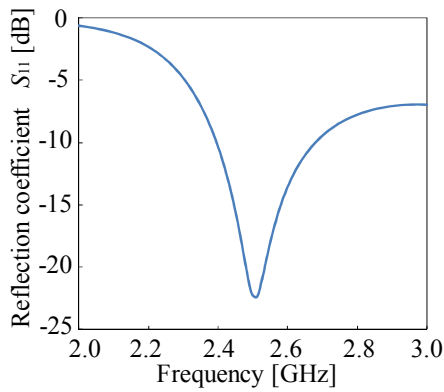
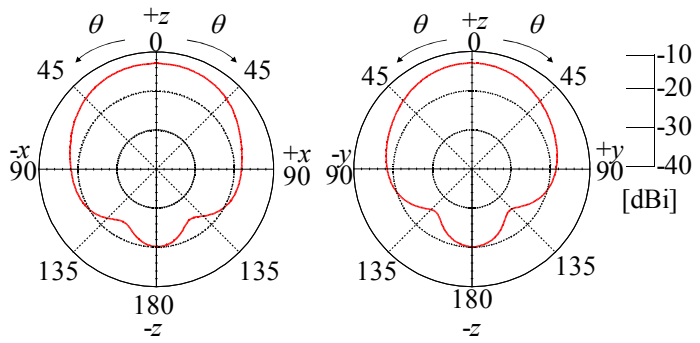

Figure 3 : Reflection coefficient



(a) x-z plane (b) y-z plane
Figure 4 : Radiation pattern

5. Analysis Using High Resolution Model

The characteristics of the proposed antenna had been investigated with 3 layers rectangular phantom. However, realistic human body is complicated. In order to confirm the validity of the phantom, the proposed antenna is buried into high resolution whole model and analyzed by use of the FDTD method. Figure 5 shows the high resolution whole model of Japanese adult male with average height and weight [5]. This model consists of 51 tissues. The proposed antenna is implanted into the upper arm of the model. The antenna position is same as the calculation using the rectangular phantom.

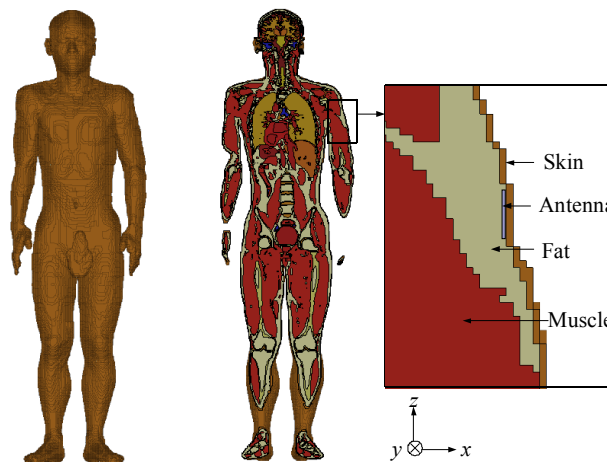

Figure 5 : High resolution model

5. Calculation Result of the High Resolution Model

Figure 6 shows the calculated reflection coefficient of the proposed antenna when the antenna is buried into high resolution model. According to the result, the reflection coefficient at 2.45 GHz is -26.8 dB. Figure 7 shows radiation pattern in the x-z and x-y planes. The gain of +x direction is important, different from earlier because distance to the outside of the body is the nearest. The gain of +x direction both in x-z and x-y planes is -12.6 dBi. The gain is enough to communicate with the external equipment. Moreover, the result indicates that communication range of the antenna which is buried into high resolution model is wider than rectangle-buried one. It shows that the proposed antenna can use for implantable devices even if the device is buried into human body.

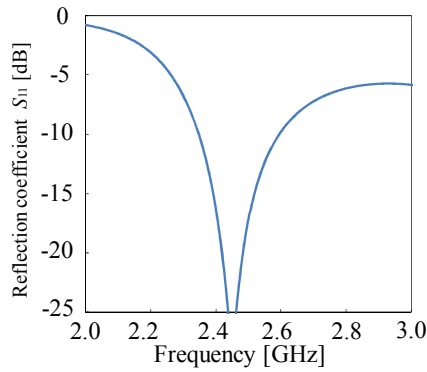
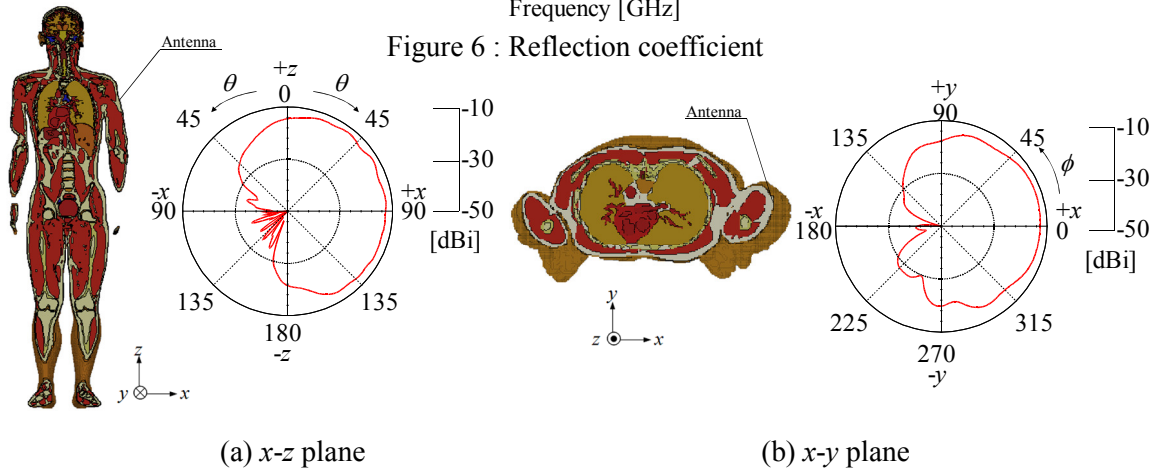

Figure 6 : Reflection coefficient



(a) x-z plane

(b) x-y plane

Figure 7 : Radiation pattern

6. Conclusion

In this report, implanted antenna which has a planar structure was proposed. Also, from the link budget, the proposed antenna gain should be more than -18.0 dBi. As the results of the calculation of using rectangular phantom and high resolution model, the reflection coefficient of the antenna was enough for impedance matching at 2.45 GHz and the gain is more than -18.0 dBi centered at desired direction. In future study, the proposed antenna will be fabricated and measured input impedance and radiation pattern in order to confirm the validity of the calculation.

Acknowledgments

This work was supported by Grant-in-Aid for Scientific Research(C) 21560384.

References

- [1] P. Soontornpipit, "Design of implantable antennas for communication with medical implants," M. S. Thesis, Dept. Elect. Comput. Eng., Utah State Univ., Logan, UT, 2002.
- [2] J.Kim and Y. Rahmat-Samii, "Implanted antennas inside a human body: Simulations, designs, and characterizations," *IEEE Trans. Microw. Theory Tech*, vol. 52, no. 8, pp. 1934-1943, Aug. 2004.
- [3] "ERC recommendation 70-3 relation to the use of short range devices (SRD)," in *Eur. Postal Telecommunications Administration Conf.*, Troms, Norway, 1997, CEPT/ERC70-03, Annex 12.
- [4] S. Yamada, D. Araki, P. Wang, S. Obote, *et al.*, "Study on a mutual coupling and maximum read range in RFID," *Proceedings of the 2007 IEICE Society conference*, p. S-6, Sept. 2007. (in Japanese)
- [5] T. Nagaoka, S. Watanabe, *et al.*, "Development of realistic high-resolution whole-body voxel models of Japanese adult males and females of average height and weight, and application of models to radio-frequency electromagnetic-field dosimetry," *Physics in Medicine and Biology*, vol. 49, pp. 1-15, 2004.