

# Direction of arrival estimating array antenna

# Hirotooshi Sakai<sup>1</sup>, Eisuke Nishiyama<sup>2</sup> and Ichihiko Toyoda<sup>3</sup>

<sup>1,2,3</sup> Graduate School of Science and Engineering, Saga University  
1, Honjo-machi, Saga-shi, Saga, 840-8502, Japan

E-mail: <sup>1,2</sup> [sakai\\_nisiyama@ceng.ec.saga-u.ac.jp](mailto:sakai_nisiyama@ceng.ec.saga-u.ac.jp), <sup>3</sup> [toyoda@cc.saga-u.ac.jp](mailto:toyoda@cc.saga-u.ac.jp)

## 1. Introduction

Recently, many kinds of radio communication and sensing systems using microwave and millimeter wave are actively developed. In the systems, highly integrated wireless devices having a function of RF signal processing are required for miniaturization and simplification [1].

In this paper, a novel array antenna for DOA estimation systems using a phase mono pulse mechanism is proposed. The proposed array antenna consists of patch elements and a both-sided feed line circuit including Magic-T circuits [2]. In the DOA estimation, the arrival angle is obtained by sum and difference of received signals on two pairs of patch elements. The proposed array antenna estimates arrival angle by taking the power ratio of the sum and difference which are easily obtained using the simple Magic-T circuit. The principle of the DOA estimation system using the propose array antenna is described in section 2 and 3. The characteristics of the proposed antenna are also discussed in section 4.

## 2. Principle of the proposed DOA estimation

Figure 1 shows the proposed antenna for DOA estimation systems. This antenna is composed of a 4-element antenna array and two magic-T circuits. When RF signal is received by the antenna elements, summed and differential signals are obtained at Port 1 and Port 2, respectively.

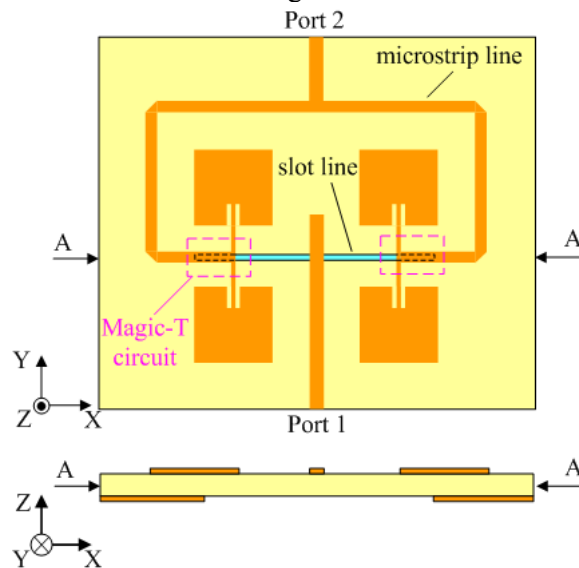

Figure 1: Structure of DOA estimating array antenna

In this paper, a phase mono pulse system shown in Fig. 2 is used for DOA estimation. When the phase difference of the signals received by the antenna elements #1 and #2 is  $\Delta\phi$  [deg.], the arrival angle  $\theta$ [deg.] can be obtained by the following equation.

$$\theta = \sin^{-1} \frac{\lambda \Delta\phi}{2\pi d} \quad (1)$$

where  $d$  and  $\lambda$  are the distance between antenna elements and carrier wavelength, respectively. Fig. 3 shows a vector chart to explain the principle of the DOA estimation. When the RF signal is

received by the antenna elements #1 and #2 with the phase difference of  $\Delta\phi$  and the same amplitude, vector sum and vector difference of the signals on the antenna elements #1 and #2 become  $\Sigma$  and  $\Delta$  in Fig. 3, respectively. Therefore, the phase angle between  $\Sigma$  and  $\Delta$  becomes  $\Delta\phi/2$ . Then the phase difference  $\Delta\phi$  can be derived by the following equation.

$$\tan \frac{\Delta\phi}{2} = \frac{\Delta}{\Sigma} \quad (2)$$

$$\Delta\phi = 2 \tan^{-1} \frac{\Delta}{\Sigma} \quad (3)$$

Here, substituting (3) for  $\Delta\phi$  in (1), arrival angle  $\theta$  can be calculated using the ratio of  $\Sigma$  and  $\Delta$ -signals as follow:

$$\theta = \sin^{-1} \left( \frac{\lambda}{\pi d} \tan^{-1} \frac{\Delta}{\Sigma} \right) \quad (4)$$

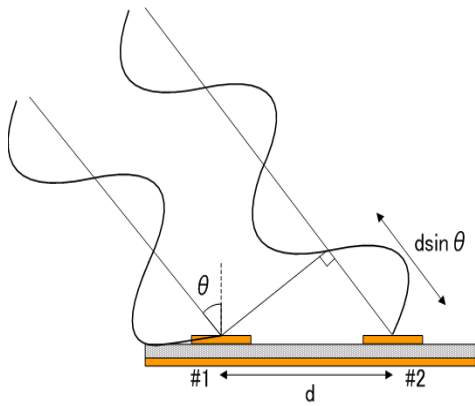

Figure 2: Principle of phase mono pulse system

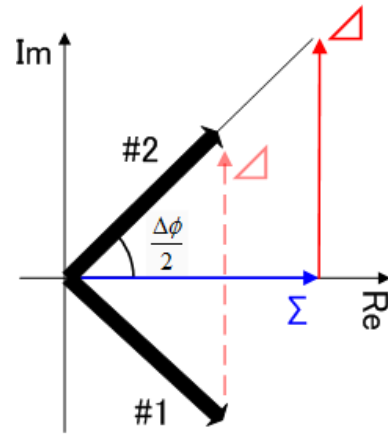

Figure 3: Vector chart

### 3. Operating principle of the proposed antenna

Figure 4 shows the operating principle of a Magic-T circuit. When RF signals are fed to Port 1 and Port 2 in phase, the RF signals are combined and propagate to Port 4. On the other hand, when RF signals are fed to Port 1 and Port 2 in anti-phase, the RF signals are combined and propagate to Port 3 due to the strip-slot combiner. Fig. 5 shows the basic behaviour of the proposed antenna. When the phase of the signal received by antenna elements #1 and #3 is  $\phi_1$ , and the phase of the signals received by antenna elements #2 and #4 is  $\phi_2$ , the phase difference  $\Delta\phi$  is  $\phi_2 - \phi_1$ . The signal received by each antenna element is fed to the Magic-T circuit through a microstrip line. The in-phase component of the received signal is fed to the Magic-T circuit in anti-phase because the feed points of the antenna elements are located at the opposite side of the patch each other. Then the in-phase components are combined and output from Port 1 as the  $\Sigma$ -signal. On the other hand, the anti-phase component of the received signal is output from Port 2 as the  $\Delta$ -signal.

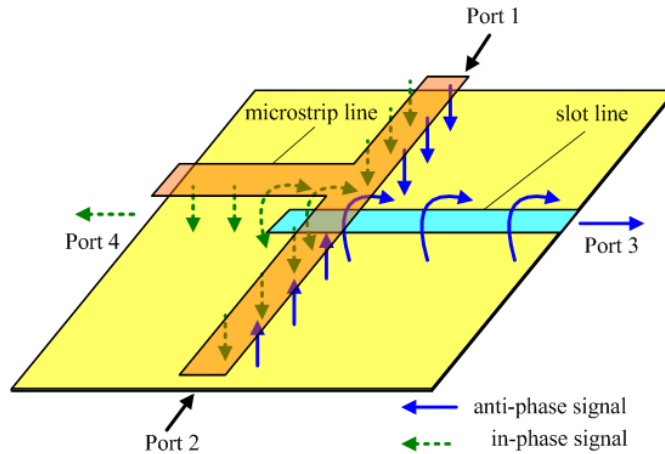

Figure 4: Operating principle of Magic-T circuit

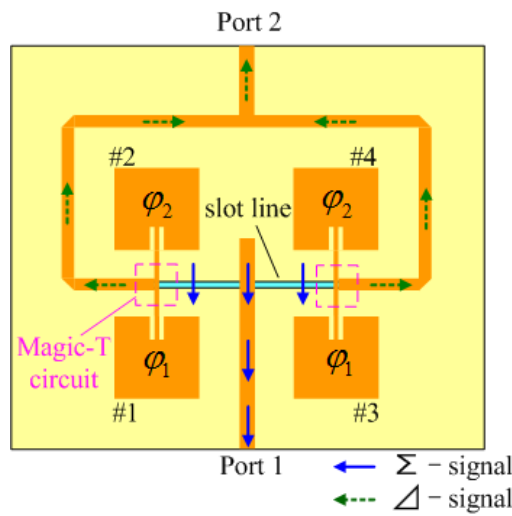

Figure 5:  $\Sigma$  and  $\Delta$ -signal flow

### 3. Characteristics of the proposed antenna

The characteristics of the proposed array antenna are investigated by electromagnetic simulation and experiment. Momentum (Agilent Technologies) is used for the simulation. The design frequency is 10 GHz and substrate parameters are shown in Table 1. Fig. 6 shows the S-parameters of the experiment result. As shown in Fig. 6, return loss (S11, S22) of better than -20 dB and isolation (S21) of better than -25 dB are obtained at 10 GHz. Good return loss and isolation characteristics are obtained. Fig. 7 shows the radiation patterns measured at Port 1 and Port 2. The output power at  $\Sigma$  and  $\Delta$  are the output power at Port 1 and Port2, respectively.  $\Delta/\Sigma$  can be derived from the angle characteristics of the  $\Sigma$ - and  $\Delta$ - signal shown in Fig. 7. Fig. 8 shows the relation between  $\Delta/\Sigma$  and arrival angle. Arrival angle between 0- to 40-deg. was detected for the received power density of  $0.0003W/m^2$ . Basic behaviour has been confirmed.

Table 1: Substrate parameters

Thickness	0.8 mm
Thickness of conductor	0.018 mm
Relative dielectric constant ( $\epsilon_r$ )	2.15
Dielectrics loss ( $\tan\delta$ )	0.0004

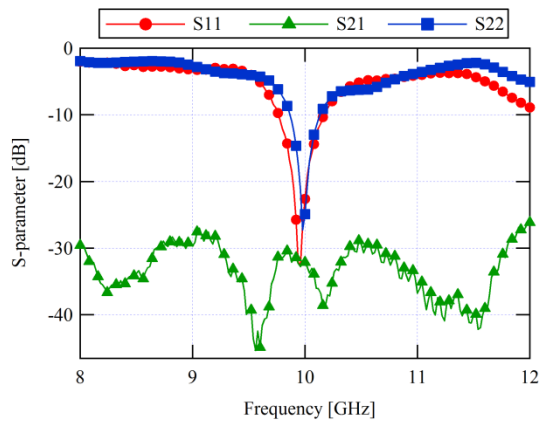

Figure 6: Measured S-parameter of the proposed array antenna

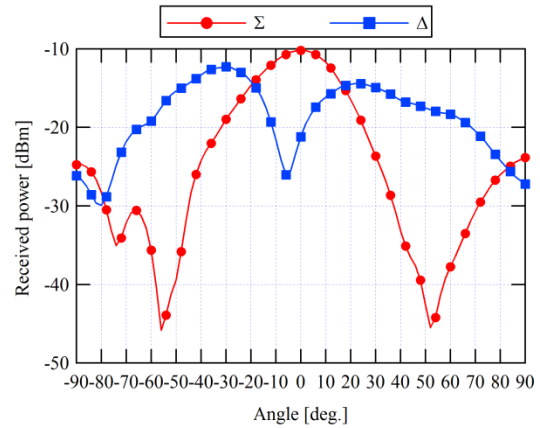

Figure 7: Measured radiation pattern of  $\Sigma$ -signal and  $\Delta$ -signal

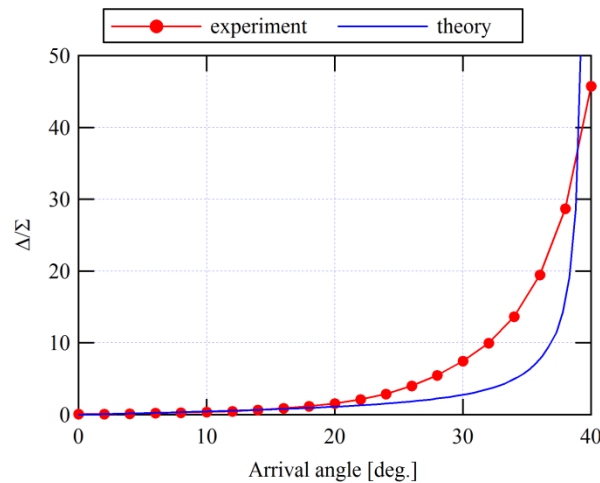

Figure 8: Relation between  $\Delta/\Sigma$  and arrival angle

### 3. Conclusion

In this paper, a novel array antenna for DOA estimation system is proposed. The proposed array antenna was evaluated by the EM simulation and experiment. Basic behaviour has been confirmed. The proposed DOA estimation system can be achieved in a very simple structure using the proposed array antenna which has two radiation patterns and directly outputs  $\Sigma$ - and  $\Delta$ - signals due to the Magic-T circuits.

### References

- [1]Y. Yamaguchi, "Fundamentals and Applications of polarimetry radar metric," IEICE, 2007.
- [2]Masayoshi Aikawa, Hiroyo Ogawa, "Double-Sided MIC's and Their Applications," *IEEE Trans.* Vol.37, no.2. pp. 406-413, February, 1989.