

An RF Multiplier Integrated Planar Antenna for DOA Estimation

Rimi Rashid, Daiki Hattori, Eisuke Nishiyama and Ichihiko Toyoda
 Graduate School of Science and Engineering
 Saga University, Japan

Abstract – A new RF multiplier integrated planar antenna is proposed to enhance the estimation capability of a phase monopulse direction-of-arrival (DOA) estimation antenna. The conventional monopulse DOA estimation antenna determines the arrival angle using only the amplitude ratio of the sum (Σ) and difference (Δ) of the signals received by two antennas. Hence, it can be used only for the half angle of the space. The proposed antenna employs an RF multiplier to detect the phase relation between the Σ and Δ signals and increase the range of the estimation angle. The basic concept of the proposed antenna is experimentally confirmed by using a prototype antenna.

Index Terms — DOA estimation antenna, phase monopulse, magic-T, RF multiplier.

1. Introduction

The principle of direction-of-arrival (DOA) estimation is used in many engineering applications such as wireless communications, radar, radio astronomy, sonar, tracking of various objects, navigation, rescue and other emergency assistance devices.

A monopulse mechanism was proposed for DOA estimation [1]. We have also proposed a monopulse DOA estimation antenna which consists of a microstrip array antenna and magic-Ts [2]. In the DOA estimation process, the arrival angle is determined by the sum and difference of the received signals of two antenna elements. The DOA estimation antenna with detectors and amplifiers was also described in [3]. In these conventional DOA estimation antennas, only the amplitude of the sum and difference of the received signals are considered. In this paper, an RF multiplier integrated planar antenna is proposed to enhance the estimation capability of the DOA estimation antenna.

2. Principle, Design and Structure

Fig. 1 shows a block diagram of the proposed antenna with a vector diagram to explain its basic concept. As illustrated in Fig. 1(a), a magic-T is used to obtain the sum (Σ) and difference (Δ) of the two received signals. The arrival angle θ can be obtained by monopulse mechanism and expressed in the following equation using Σ and Δ . [4].

$$\theta = \sin^{-1} \left(\frac{\lambda}{\pi d} \tan^{-1} \frac{|\Delta|}{|\Sigma|} \right) \quad (1)$$

where d and λ are the antenna separation and wavelength, respectively. Here, as only the amplitude ratio of Σ and Δ signals is used in this expression, the sign of the Δ signal, i.e., the phase relation between Σ and Δ signals is not considered.

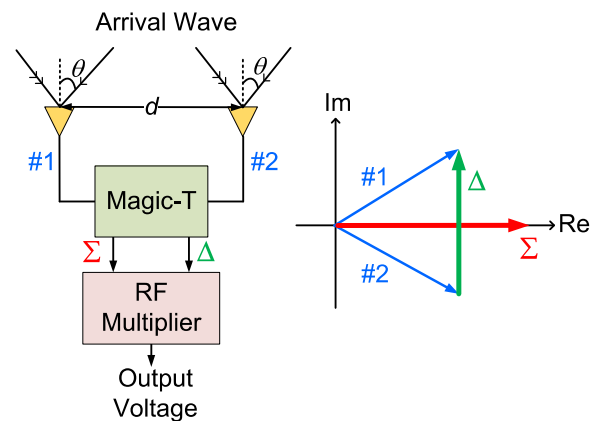

(a) Block diagram (b) Vector diagram
 Fig.1. Basic concept of the proposed antenna.

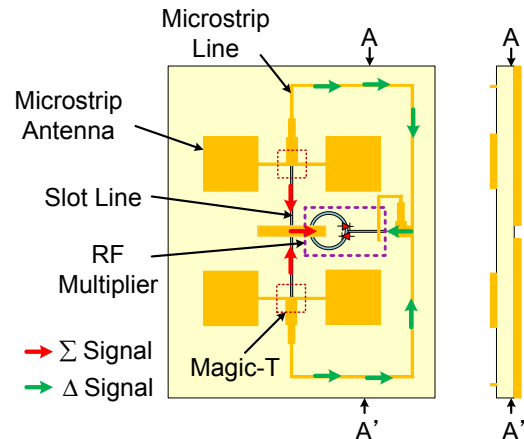

Fig. 2. Structure of the proposed antenna.

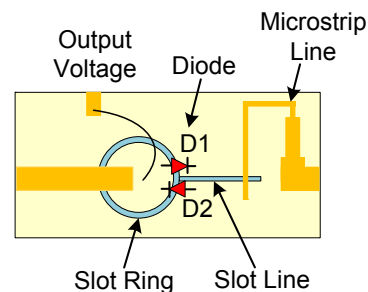

Fig. 3. RF multiplier.

Fig. 1(b) shows a vector diagram of the signals where the phase difference between Σ and Δ is 90° . As shown in this diagram, the phase relation between two received signals can be determined by evaluating the phase relation between Σ and

Δ signals. When the phase of Δ is advanced from Σ , #1 leads #2. On the other hand, it will be vice versa. Then the antenna can discriminate right and left side of the arrival angle. In this paper, an RF multiplier is employed to determine whether the phase of Δ signal is advanced or delayed from Σ signal.

Fig. 2 shows the structure of the proposed RF multiplier integrated planar antenna which consists of four antenna elements, two magic-Ts and an RF multiplier.

3. RF Multiplier

Fig. 3 shows the structure of the RF multiplier used in the proposed antenna. It consists of microstrip lines, slot line, slot ring and two diodes (D1 and D2). The output of this circuit depends on the phase difference of the input signals [5], [6]. In this proposed antenna structure, the input signals of the RF multiplier are Σ and Δ signals. The output of the RF multiplier V_{mul} can be expressed by the following equation:

$$V_{mul} \propto A_{\Sigma} A_{\Delta} \cos(\theta_{\Sigma} - \theta_{\Delta}) \quad (2)$$

where θ_{Σ} , θ_{Δ} are the phase and A_{Σ} , A_{Δ} are the amplitude of the Σ and Δ signals, respectively. In equation (2) when $\theta_{\Sigma} - \theta_{\Delta} = 0^{\circ}$ or 180° , V_{mul} is either positive or negative. The in-phase and anti-phase modes of these input signals determine the sign of the output voltage. Depending on the output voltage, either positive or negative, the direction of the arrival wave can be perceived. As each phase shift of the Σ and Δ signals from the magic-Ts depends on the frequency, the antenna is designed to provide maximum V_{mul} at the desired frequency.

4. Measured Result

Fig. 4 shows the photo of the prototype antenna. In this fabricated antenna, output of the RF multiplier can be obtained from the wire on the bottom.

Fig. 5 illustrates the relation between the output voltage V_{mul} and arrival angle θ . Positive V_{mul} is observed for the arrival angle greater than 0 degrees and negative V_{mul} is observed less than 0 degrees for 10.4 GHz and 10.5 GHz frequency signals. On the other hand, the V_{mul} value is reversed at frequency 10 GHz and 9.8 GHz. As the antenna is designed for 10 GHz, extra phase difference between Σ and Δ signals is occurred at different frequencies. This is the reason for the reverse result in a different frequency range. In case of positive V_{mul} , the phase of Σ is advanced from Δ . This means that #2 leads #1. On the other hand, #1 leads #2 at negative V_{mul} . Very close to zero V_{mul} is observed at arrival angle of 0 degrees where the amplitude of the Δ signal becomes zero, i.e., $A_{\Delta} = 0$.

5. Conclusion

An RF multiplier integrated planar antenna is proposed for monopulse DOA estimation and experimentally examined. The conventional monopulse DOA estimation antenna can be used for the half angle of the space because the arrival angle is perceived by the amplitude of the sum and difference of the signals received by two antennas. The proposed antenna determines the phase relation between the sum and difference signals and it provides wide-angle estimation by the

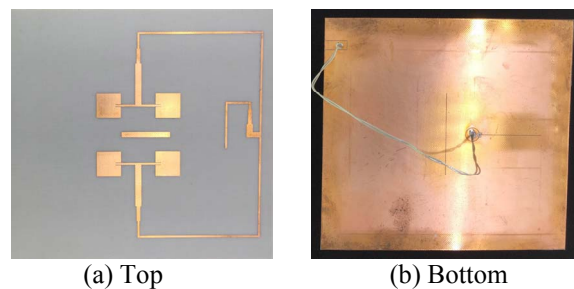

Fig. 4. Prototype antenna (106 × 100 mm, $f = 10$ GHz).

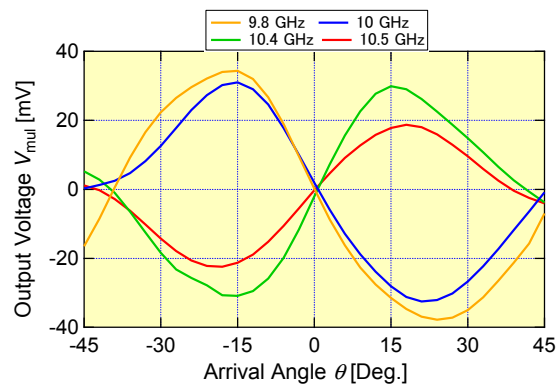

Fig. 5. Measured performance of the prototype antenna.

combination with monopulse DOA estimation. The structure of the antenna is simple and it can be used in a wide range of applications in DOA estimation.

Acknowledgment

The authors would like to thank Dr. Takayuki Tanaka, Saga University for his fruitful discussions. This work was supported in part by JSPS KAKENHI Grant Number 26420361.

References

- [1] W. Kederer and J. Detlefsen, "Direction of arrival (DOA) determination based on monopulse concepts," Proc. 2000 Asia-Pacific Microwave Conf. (APMC2000), pp. 120-123, Sydney, NSW, Dec. 2000.
- [2] H. Sakai, E. Nishiyama, and I. Toyoda, "Direction of arrival estimating array antenna," Proc. 2012 Int'l Symp. Antennas and Propag. (ISAP2012), pp. 1124-1127, POS2-24, Nagoya, Oct. 2012.
- [3] R. Tanaka, E. Nishiyama, and I. Toyoda, "A mono-pulse DOA estimation antenna integrated with RF amplifiers and detection circuits," 2014 Int'l Symp. Antennas and Propag. and USNC-URSI Radio Sci. Mtg. (APSURSI2014) Dig., 526.3, Memphis, TN, July 2014.
- [4] D. P. Jorgensen, T. Matejka, and J. D. DuGranrut, "Multi-beam techniques for deriving wind fields from airborne Doppler radars," Meteorol. Atmos. Phys., Vol. 59, Issue 1-2, pp. 83-104, Mar. 1996.
- [5] S. Matsuyuki, E. Nishiyama, and I. Toyoda, "Prototype evaluation of a PSK modulator/demodulator for space modulation system," Joint conf. Kyushu, 03-1P-08, Sep. 2013.
- [6] M. A. Hossain, Y. Ushijima, E. Nishiyama, I. Toyoda, and M. Aikawa, "Orthogonal circular polarization detection patch array antenna using double balanced RF multiplier," Prog. In Electromagnetic Research C, Vol. 30, 65-80, 2012.