

A Compact Circular Polarization Active Phased Array Antenna with Low Axial Ratio

Chao-ran Hu^{1,2}, Shu Lin¹, Ling Liu¹, Cai-tian Yang¹, Ming-chuan Wei², Xi-bin Cao²

¹ School of Electronics and Information, Harbin Institute of Technology, Harbin, Heilongjiang, China

² Research Center of Satellite Technology, Harbin Institute of Technology, Harbin, Heilongjiang, China

Abstract: This paper presented a circular polarization active phased array patch antenna with small scale and low axial ratio, which worked on the frequency of S-band and the relative bandwidth is 4%. The array contained 4 notched-rectangular patch antenna elements and these 2×2 array were fed by independent coaxial method, phase shift was done in baseband. This design reduced the effects of the complex feeding network on axial ratio and phase. And the distance between each antenna element was only half of free space wavelength, so the size of whole array was reduced significantly. This antenna can also be combined into a bigger array with more elements, then make the miniaturization of the array more obvious.

Index Terms — Miniaturization, Circular Polarization, Active Array, Low Axial Ratio.

1. Introduction

With the development of the printed circuit board technology, the patch antenna array has been used widely with the advantages of low-profile, light weight and suitable for mass production [1-3]. However, this type of antenna array needs complex feed network, and with the quantity of the elements increasing, the complexity of the feeding network is increasing. Then bring some problems such as there is coupling between elements and feed lines, which will decrease the gain of the array antenna and make the axial ratio terrible. Then we have to increase the distance between each antenna element to cut down the coupled effects, but it will significantly increase the size of the antenna array again, which doesn't benefit to miniaturization. This paper presented a 2×2 patch antenna array with independently feeding ports, each element connected directly with an RF circuit, by changing the digital signal which was typed into these circuit, the output amplitude and phase of the circuit can be controlled. Thus circular polarization and beam scanning of the array antenna can be realized. The simulation result indicated that when we scan the beam, the axial ratio of the antenna array can stay low. What's more, the distance between each antenna element was only half of free space wavelength, which could decrease the size of the array significantly.

2. Structure of the Antenna Array

(1) Structure of the antenna element and 2×2 array

The Structure of the antenna element and array are shown in Fig. 1, the element is notched-rectangular patch

antenna. These 4 elements were combined into a 2 × 2 antenna array. The dimension is as follows: $L_t = 70$ mm, $m = 7$ mm, $C = 3.8$ mm, $L = 31.2$ mm, $L_m = 150$ mm, $d = 66$ mm. They were printed on a FR-4 epoxy resin, the board's thickness is $h = 1.6$ mm and relative dielectric constant is $\epsilon_r = 4.3$. Each element was fed by a coaxial probe. The coaxial cable's diameter of inner conductor is 1 mm, and the outer conductor is 2.5 mm.

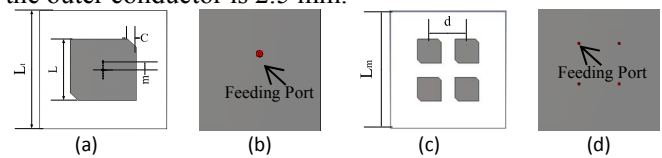

Fig. 1. Structure of the Antenna Element.

(a - top view, b - bottom view, c - top view, d - bottom view)

(2) Schematic of the Active Circuit

There is a circuit schematic diagram shown in Fig. 2, which is used to feed the 4 ports of the antenna array. The circuit was made up with 4 selfsame subsystem, each subsystem contains a DAC, a quadrature modulator and an amplifier, and a local oscillator was divided into 4 equal parts for the four quadrature modulators. The traditional feeding network is by changing the propagation time t in microstrip to realize the phase shift. According to the working principle of the quadrature modulator as in (1) and (2), by controlling the digital signal to change the output level of $I(t)$ and $Q(t)$ from the DAC can make the value of φ controllable, then phase shift can also be achieved.

$$S(t) = I(t) \cdot \cos(\omega_0 t) - Q(t) \cdot \sin(\omega_0 t) \tag{1}$$

$$= \text{Re}\{\exp[j(\omega_0 t + \varphi)]\} \tag{2}$$

$$\varphi = \arctan[Q(t)/I(t)]$$

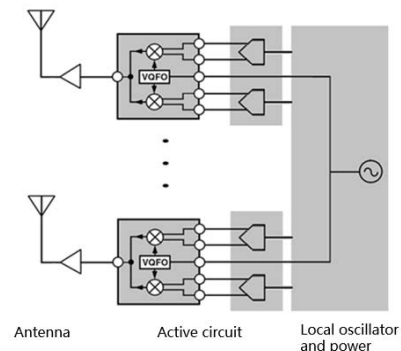

Fig. 2. Circuit Schematic Diagram

3. Simulation and Measurement

(1) The Impedance Characteristic of Antenna Element

There's a reflection coefficient plot of the antenna shown in Fig. 3, it's the simulated and measured results of the antenna element. As can be seen from the plot that the working frequency of the antenna is 2.22 ~ 2.30 GHz. Then we studied the radiation characteristics of the antenna under this frequency.

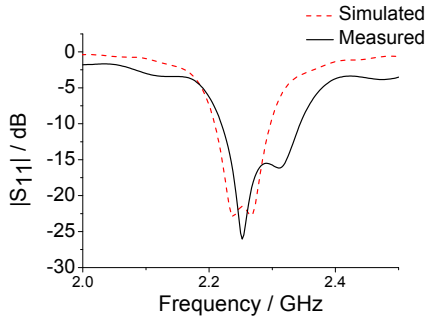

Fig. 3. Impedance Characteristic of Antenna Element.

(2) Simulated result of beam scanning

Established the antenna model in CST Microwave Studio®, and feed the 4 ports with different amplitude or phase, then getting the result of beam scanning. Fig. 4 shows the main lobe direction with different feeding phase and amplitude. From the results, it can be seen that phase is the main factor to influence the main lobe direction, phase difference increases every 5° will make the main lobe direction change 1°. The amplitude's effect to radiation pattern is slight, as the amplitude ratio changing, the main lobe direction changed less than 3° all the time. So we should adjusted the phase more exactly.

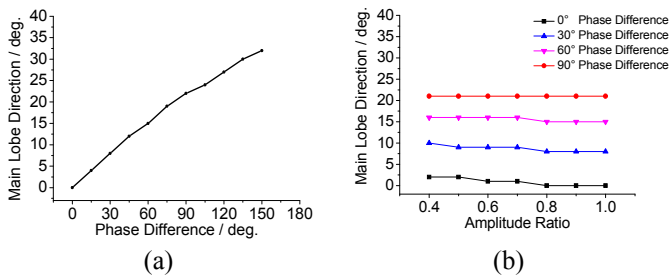

Fig. 4. Main Lobe Direction with Different Phase and Amplitude

Fig. 5 shows the axial ratio with different feeding phase or amplitude. As can be seen that when the phase difference is less than 100° and the amplitude ratio is greater than 0.8, their influence to axial ratio is slight. However, even if the phase difference becomes greater or the amplitude ratio gets smaller, the axial ratio is always less than 3dB.

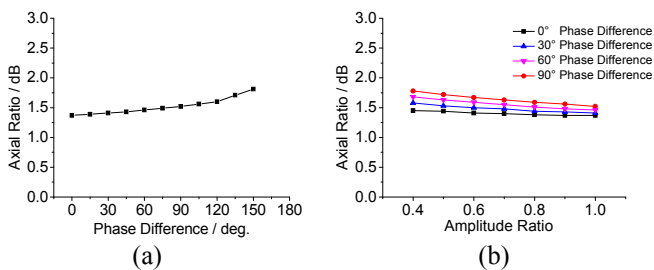

Fig. 5. Axial Ratio with Different Phase and Amplitude

(3) Test of Phase Shift Function

Fig. 6 shows the appearance of the antenna array. There should be 4 units per layer, in order to be observed clearly, not all units installed. The top layer are patch antennas, middle layer are active circuits and bottom layer are baseband part and the local oscillator. Port A is the RF signal output part from the active circuit to feed for the antenna elements. Part B is the digital interface between baseband and DAC. Controlling the baseband digital signal can change phase of the RF signal, using a network analyzer to test the phase difference between input and output signal to verify it.

Table I shows measured results of the antenna. First column is the expected degree that we want to change, the second column is the result that actual measured. And the last column is the error between the measurement and theoretical values. As can be seen that the maximum error of the phase difference is 8.2° and will error less than 2° in main lobe direction. It can satisfy the requirements for normal using. And if want to get a more exactly phase, it can be adjusted through the baseband signal.

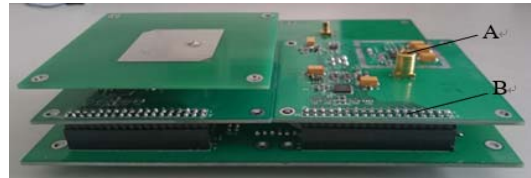

Fig. 6. Impedance Characteristic of Antenna Element.

TABLE I
Test of Phase Difference

Expectation/deg.	Measured/deg.	Error/deg.
30	31.6	1.6
60	57.2	-2.8
90	85.2	-4.8
120	114.8	-5.2
150	141.8	-8.2
180	173.7	-6.3
210	205.4	-4.6
240	234.4	-5.6
270	267.2	-2.8
300	301.0	1.0
330	329.1	-0.9
360	359.4	-0.6

4. Conclusion

Designed an active circular polarization phased array antenna, the distance between each element of the array is only half of free space wavelength. Realized the beam scanning angle from -30° ~ +30° at the frequency of 2.22 ~ 2.30 GHz. This antenna array had small scale and can be combined to a bigger array with more elements.

References

- [1] Ting Shu, "Design Considerations for DBF Phased Array 3D Surveillance Radar," *Proceedings of 2011 IEEE CIE International Conference on Radar*, vol. 1, pp. 360 - 363, 2011.
- [2] Gong Wen-bin, "DBF Multi-Beam Transmitting Phased Array Antenna on LEO Satellite," *ACTA ELECTRONICA SINICA*, vol. 38, no. 12, pp. 2904-2909, Dec. 2010.
- [3] Fu Shi-Qiang "Broadband Circularly Polarized Slot Antenna Array Fed by Asymmetric CPW for L-Band Application," Fu Shi-Qiang: *IEEE Antennas and Wireless Propagation Letters*, vol. 8, 2010, pp.1014-1016, 2009.