

Equivalent Circuit of Intra-Body Communication Channels Based on a Lossy Conductor Model

Nozomi Haga¹ and Koichi Ito²

¹ Graduate School of Engineering, Gunma University
1-5-1 Tenjin-cho, Kiryu, Gunma 376-8515, Japan, haga@el.gunma-u.ac.jp

² Graduate School of Engineering, Chiba University
1-33 Yayoi-cho, Inage-ku, Chiba 263-8522, Japan, ito.koichi@faculty.chiba-u.jp

1. Introduction

The physical channels establishing intra-body communications were first treated as capacitive circuits by Zimmerman [1]. However, the conventional circuit model is of assuming capacitances only between particular conductors, and is not based on quantitative analyses; therefore, its validity had been unclear for a long time. For this reason, we have derived an improved circuit model by solving a boundary value problem of electric potentials of conductors [2]. However, the applicable scope of the improved model is still limited for two reasons. One is that the wavelength should be sufficiently longer than the human body. The other is that the conduction currents inside the human body should be sufficiently little because the human body is approximated as a perfect electric conductor (PEC) in both the conventional and improved models. In contrast, the transmitter investigated by Fujii was designed so as to induce conduction currents inside the human body [3]; therefore, the PEC model is no longer applicable even if the frequency is sufficiently low. Regarding the former problem, some researchers extended Zimmerman's circuit model to simulate the frequency dependence of the communication channels [4], [5]. However, the circuit parameters in their models were just assumed or determined so that the received voltage calculated by the circuit model fits with the measured or simulated results. In a strict sense, it is difficult to represent the channel characteristics by a circuit model at such a high frequency. On the other hand, the latter problem can be properly handled if the frequency is sufficiently low. In the present paper, the equivalent circuit for lossy conductors is derived and the physical mechanism of the communication channels inducing conduction currents inside the human body is addressed.

2. Calculation Model

Figure 1 (a)–(c) shows the transmitter (Tx), the receiver (Rx), and the arm model with the transmitter and the receiver. The geometries of them are identical to those investigated by Fujii [3]. As shown in Fig. 1 (a), the transmitter consists of a circuit board and two electrodes. One electrode is of inducing a signal voltage to the body; so it is called “signal electrode”. Another electrode is equal to the circuit board in potential; so it is called “ground electrode” or simply denoted as “GND”. According to [3], signal transmission characteristics can be improved by attaching both the signal and ground electrodes to the human body. These electrodes are positioned at both ends of the circuit board. In addition, a construction without the ground electrode is investigated to clarify the role of the ground electrode. On the other hand, as shown in Fig. 1 (b), the receiver consists of a circuit board and only one electrode. The induced voltage between the electrode and the circuit board is to be detected; so the electrode is called “receiving electrode” and positioned at the end of the circuit board. The transmitter and the receiver are mounted on the arm model, as shown in Fig. 1. The relative permittivity and the conductivity of the arm are 81 and 0.62 S/m, respectively. The central point of the signal electrode is positioned 200 millimeters from the tip of the arm model, and this point shall be the origin of coordinates. All the electrodes and the circuit boards are represented by PECs, and each one is numbered as shown in Fig. 1.

Figure 2 shows the equivalent circuit of the calculation model. The resistance and capacitance components represent the spaces inside and outside the body, respectively, and they can be obtained by

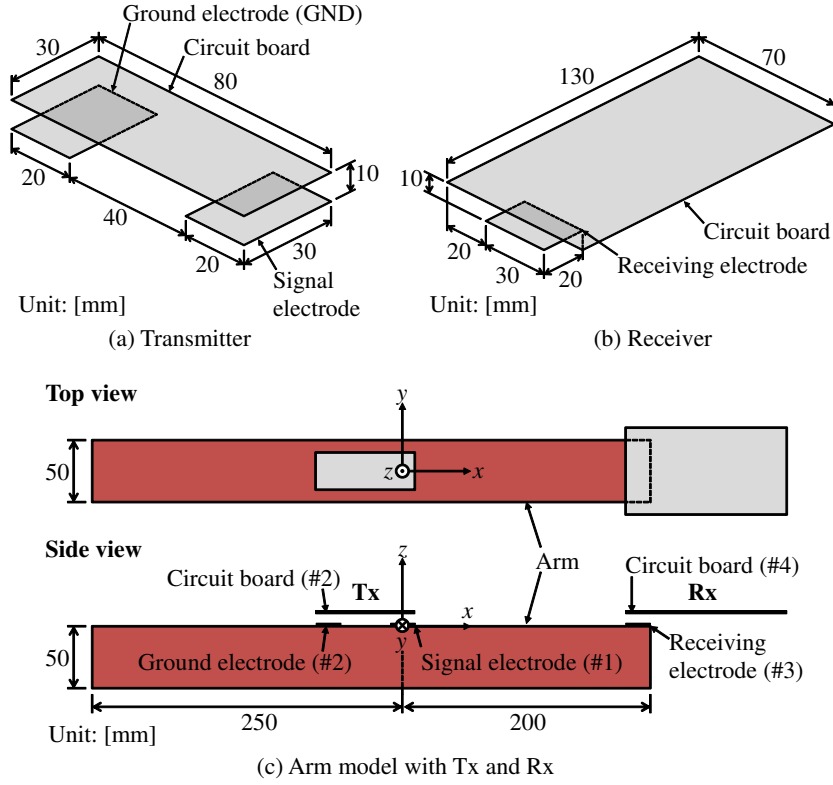

Figure 1: Calculation model

solving a boundary value problem of electric potential. For example, by obtaining the inflowing current of each electrode under a condition of $V_1 = 1$ and $V_2 = V_3 = 0$, the resistance components are found as $R_{12} = -1/I_2$ and $R_{13} = -1/I_3$, where V_i and I_i are the potential and the inflowing current of PEC # i ($i = 1, \dots, 4$). On the other hand, to obtain the capacitance components, the non-uniformity of electric potential on the body should be considered. According to the uniqueness theorem and the superposition principle, the distributions of the potential ϕ and the charge density ρ on S are linear with respect to the potentials of the PECs, that is,

$$\phi(\mathbf{r}) = V_1 f_1(\mathbf{r}) + V_2 f_2(\mathbf{r}) + V_3 f_3(\mathbf{r}) + V_4 f_4(\mathbf{r}) \quad (1)$$

$$\rho(\mathbf{r}) = V_1 g_1(\mathbf{r}) + V_2 g_2(\mathbf{r}) + V_3 g_3(\mathbf{r}) + V_4 g_4(\mathbf{r}) \quad (2)$$

where $f_i(\mathbf{r})$ and $g_j(\mathbf{r})$ are interpolation functions. The capacitance coefficient between PECs # i and # j can be defined as follows.

$$c_{ij} = \int_S f_i(\mathbf{r}) g_j(\mathbf{r}) dS \quad (3)$$

where S is whole the surface region. Equation (3) means that the capacitance coefficients can be obtained by integrating the charge distributions weighted by the potentials. This definition is consistent in terms of electrostatic energy, and we have equality of $c_{ij} = c_{ji}$. The capacitances as circuit parameters can be obtained as $C_{ij} = -c_{ij}$ and $C_i = \sum_{j=1}^4 c_{ij}$. In the present study, the boundary value problem of electric potential was solved by using the Galerkin's method of moments (MoM).

3. Results and Discussion

Table 1 compares the calculated equivalent-circuit parameters in the cases with and without the ground electrode. It is notable that the capacitance of the circuit board of the transmitter C_2 considerably increases by attaching the ground electrode to the arm. This result means that the dimensions of the circuit board are equivalently enlarged with the ground electrode, and so its potential is stabilized.

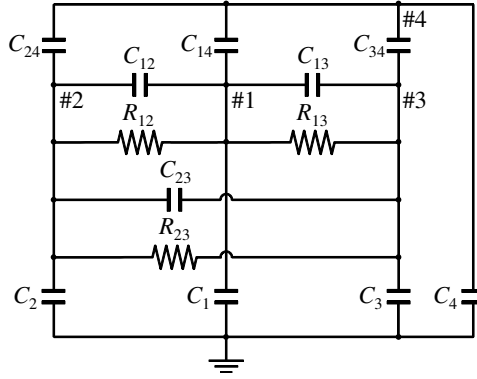

Figure 2: Equivalent circuit of the calculation model

Table 1: Calculated equivalent-circuit parameters

Parameter	with GND	w/o GND	Parameter	with GND	w/o GND
R_{12}	75.78 Ω	∞	C_{12}	0.4644 pF	3.631 pF
R_{13}	201.3 Ω	158.3 Ω	C_{13}	-0.8653 pF	-1.549 pF
R_{23}	661.8 Ω	∞	C_{14}	0.5610 pF	0.8731 pF
C_1	2.700 pF	6.420 pF	C_{23}	0.1245 pF	0.4153 pF
C_2	4.542 pF	0.3589 pF	C_{24}	0.3854 pF	0.03622 pF
C_3	2.110 pF	2.538 pF	C_{34}	2.911 pF	2.947 pF
C_4	2.290 pF	2.291 pF			

Instead, the capacitance of the signal electrode C_1 decreases with the ground electrode. It should be also noted that the capacitance between the signal and receiving electrodes C_{13} is of negative value in the both cases. That is because the capacitances are defined so as to be consistent in terms of electrostatic energy.

Table 2 summarizes the potentials of the electrodes and the circuit boards, and the received voltage for the feeding voltage of 1 V. In addition, Fig. 3 (a)–(d) shows the electric potential and field distributions at the x - z plane of $y = 0$. In the case with the ground electrode, the potential of the signal electrode V_1 and that of the circuit board of the transmitter V_2 are comparable in magnitude and opposite in sign. Consequently, the potential distributions in the arm form a balanced dipole, as shown in Fig. 3 (a). In this case, the potential of the receiving electrode is V_3 is 0.2688 V. In the case without the ground electrode, V_1 is much smaller than V_2 in magnitude. That is because C_2 is significantly small. As a result, the potential distributions only around the circuit board of the transmitter are large in magnitude, as shown in Fig. 3 (b), and V_1 and V_3 are only 0.03458 V. The difference in the electric potential results in the difference in the electric field, as shown in Fig. 3 (c) and (d).

4. Conclusion

In the present paper, the equivalent circuit of the intra-body communication channels inducing conduction currents inside the human body was derived based on MoM analyses. According to the results, the capacitance of the circuit considerably increases if both the signal and ground electrodes are attached to the human body. In this case, the potential of the circuit board is stabilized and that of the human body is raised up, and so the electric field and the received voltage can be enhanced.

Acknowledgments

The author would like to thank Associate Professors Masaharu Takahashi and Kazuyuki Saito at Chiba University for their useful advices when the author was working under their instructions.

Table 2: Potentials of the PECs and received voltage

Parameter	with GND	w/o GND
V_1 (Signal electrode)	0.5038 V	0.03458 V
V_2 (Circuit board of Tx)	-0.4962 V	-0.9654 V
V_3 (Receiving electrode)	0.2688 V	0.03458 V
V_4 (Circuit board of Rx)	0.1421 V	0.01580 V
Received voltage	0.1266 V	0.01878 V

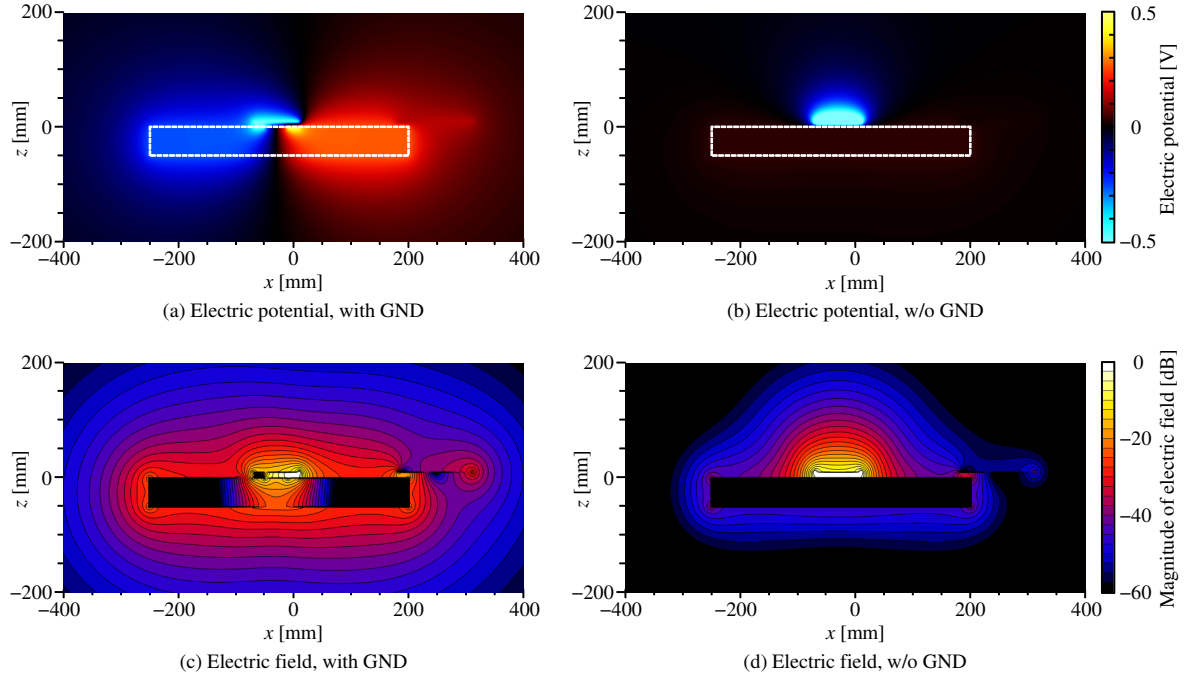

Figure 3: Electric potential and field distributions

References

- [1] T. G. Zimmerman, "Personal area networks: Near-field intra-body communication," *IBM Syst. J.*, Vol. 35, No. 3–4, pp. 609–617, 1996.
- [2] N. Haga, K. Saito, M. Takahashi, and K. Ito, "Proper derivation of equivalent-circuit expressions of intra-body communication channels using quasi-static field," *IEICE Trans. Commun.*, Vol. E95-B, No. 1, pp. 51–59, Jan. 2012.
- [3] K. Fujii, M. Takahashi, and K. Ito, "Electric field distributions of wearable devices using the human body as a transmission channel," *IEEE Trans. Antennas Propag.*, Vol. 55, No. 7, pp. 2080–2087, July 2007.
- [4] N. Cho, J. Yoo, S. Song, J. Lee, S. Jeon, H. Yoo, "The human body characteristics as a signal transmission medium for intrabody communication," *IEEE Trans. Microwave Theory Tech.*, Vol. 55, No. 5, pp. 1080–1086, May 2007.
- [5] A. Fujiwara, S. Igou, and M. Taki, "Considerations of equivalent circuit for intra-body communication," *Technical Report of IEICE*, Vol. 110, No. 332, pp. 1–6, Dec. 2010. (in Japanese)