

# Study of Noise Reduction from SMPS in the Wireless Power Transmission System

Sangbong Jeon, Jong-Hwa Kwon, Byung Chan Kim, Jung-Ick Moon, Seong-Min Kim, Sang-Won Kim, and In-Kui Cho

Radio Technology Research Department,  
Electronics and Telecommunications Research Institute,  
Daejeon, Korea  
sbjeon@etri.re.kr

**Abstract** – In this paper, the PCB layout changed to reduce the electromagnetic interference noise from switch mode power supply in the wireless power transmission system. The critical current loop minimized to reduce the radiated noise. The noise was reduced by a maximum of 18 dB compared to the previous.

**Index Terms** — Wireless power transmission, switch mode power supply, electromagnetic compatibility.

## 1. Introduction

Wireless power transmission (WPT) devices for mobile devices have been commercialized. Also, such as automotive applications, smart devices, laptops, biomedical sensors in other industries are being commercialized in progress [1-5]. The WPT technology delivers the power using magnetic field wirelessly from the transmitting coil to receiving coil. Therefore, a strong magnetic field is caused electromagnetic compatibility (EMC) especially in near-field environment as well as electromagnetic field exposure (EMF) problems [4-9]. A few studies have investigated the shielding technics to reduce electromagnetic field such as passive shield, active shield, and reactive shield [10]. The Electromagnetic shielding with shielding technology is an effective technique for reducing the noise. However, for the transmitting circuits, generally the signal outputted the square wave via the inverter circuit through the switch mode power supply (SMPS). Therefore, it is important to reduce the harmonic noise of the SMPS. Typically, the switching waveform has fast rise and fall times leading to the production of harmonics.

In this paper, we reduce the electromagnetic interference noise from the SMPS changing the layout of PCB. The layout changes to reduce the critical current loop size. As results, the noise is reduced up to 18 dB compared to the previous in certain frequency bands.

## 2. Noise reduction from SMPS

The majority of the topologies are derived from the three non-isolated topologies which are the buck, the boost, and the buck-boost. The one of the most basic topologies is the buck converter as shown in Fig. 1. During the on cycle with S1 closed and S2 open, the current follows the red loop. And during the off cycle with S1open and S2 closed, the current

follows the blue loop. Only in the green loop flows a fully switched AC current with high di/dt. We refer to the green loop as a critical loop, since it has the highest AC and EMI energy. In order to reduce the noise, we need to reduce the radiating effect of the green loop as far as possible.

Fig. 2 shows the transmitting circuit and PCB layout of the implement of the WPT system. The blue box and the left side is the buck convert as shown in Fig. 2(a) and (b).

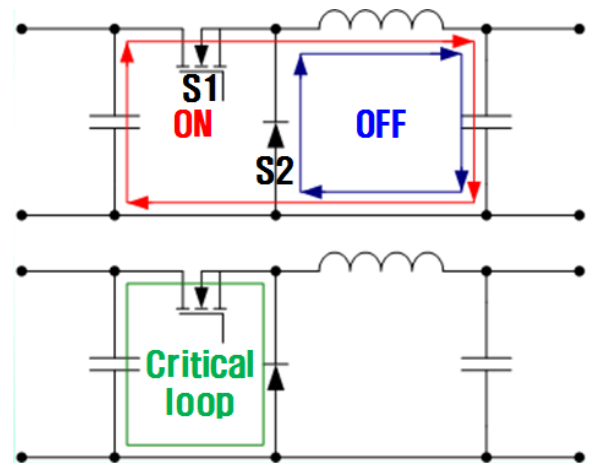
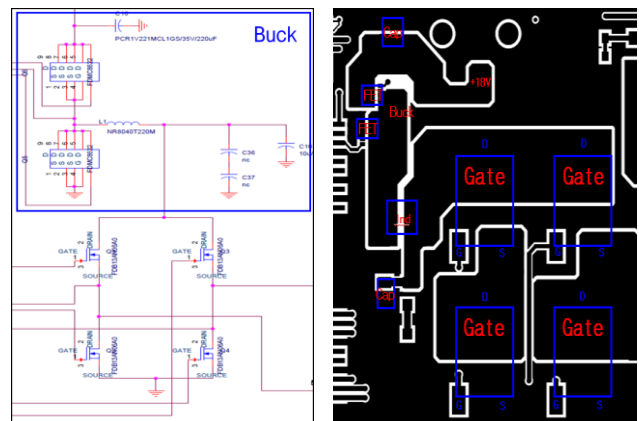

Fig. 1. Diagram of switched mode power supply (Buck).



(a) Circuit (b) PCB layout  
Fig. 2. Transmitting parts of the WPT system.

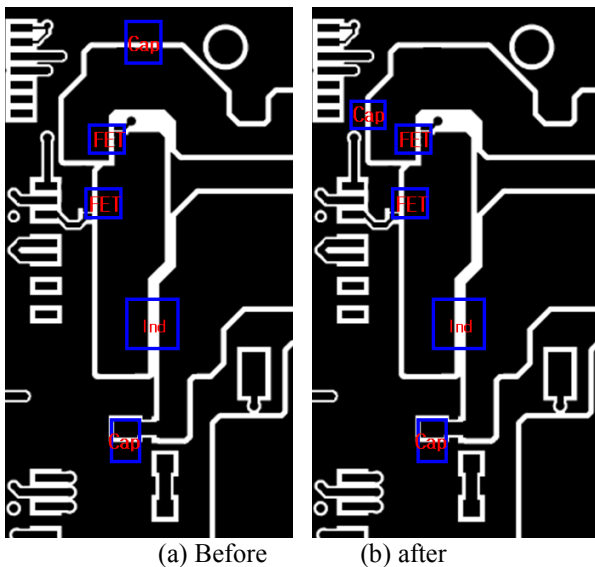

Fig. 3. Improved the layout of PCB for the noise reduction.

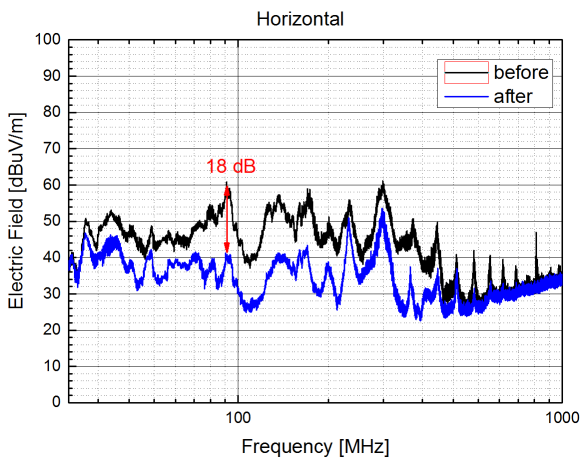

Fig. 4. Measurement of electric field before and after improved PCB.

Fig. 3 shows the improved PCB layout for the noise reduction. The area of the critical loop should be minimized by component placement and PCB layout. Fig. 3(b) shows the layout with the input capacitor placed much closer to the FET. The area of the critical loop is minimized on the PCB.

Fig. 4 shows the horizontal measurement of the electric field before and after improvement of the PCB. The radiated electric field of the PCB was measured at 10 m distance in the semi-anechoic chamber. The radiated electric field was reduced up to 18 dB compared to the before reducing the area of the critical loop.

### 3. Conclusion

In this paper, we proposed to modify the layout of the PCB in order to reduce an electromagnetic interference noise from the SMPS in the wireless power transmission systems. To reduce the radiating effect of the critical loop, the layout with the capacitor placed as far as possible closer to the FET. As the results, the electromagnetic interference noise was reduced up to 18 dB compared to the previous.

### Acknowledgment

This work was supported by National Research Council of Science & Technology (NST) grant by the Korea government.

### References

- [1] A. Kurs et al., "Wireless power transfer via strongly coupled magnetic resonances," *Science*, vol. 317, pp. 83-86, Jul. 2007.
- [2] K. S. Lee and D. H. Cho, "Simultaneous information and power transfer using magnetic resonance," *ETRI J.*, vol. 36, pp. 808-818, Oct. 2014.
- [3] D. Ahn, S. Kim, J. Moon, and I. K. Cho, "Wireless power transfer with automatic feedback control of load resistance transformation," *IEEE Trans. On Power Electronics*, in press.
- [4] S. Kim, H. H. Park, J. Kim, J. Kim, and S. Ahn, Gauss, "Design and analysis of a resonant reactive shield for a wireless power electric vehicle," *IEEE Trans. On MTT*, vol. 62, pp. 1057-1066, Apr. 2014.
- [5] S. Ahn et al., "Reduction of electromagnetic field of wireless power transfer systems using quadruple coil for laptop applications," *IEEE MTT-S International Microwave Workshop Series on Innovative Wireless Power Transmission*, pp. 65-68, May. 2012.
- [6] Y. Cho et al., "Thin PCB-type metamaterials for improved efficiency and reduced EMF leakage in wireless power transfer systems," *IEEE Trans. On MTT*, vol. 64, pp. 353-364, Feb. 2016.
- [7] S. M. Kim et al., "Advanced power control scheme in wireless power transmission for human protection from EM field," *IEEE Trans. On MTT*, vol. 63, pp. 847-856, Mar. 2015.
- [8] S. B. Jeon, S. K. Park, and D. H. Kim, "Simple method to generate dominant E- and H-fields inside a four-port TEM cell," *IEEE Trans. On EMC*, vol. 55, pp. 979-982, Oct. 2013.
- [9] S. B. Jeon, S. K. Park, J. H. Kwon, and D. H. Kim, "Analysis of electromagnetic interference under different types of near-field environments," *IET Electronics Letters*, vol. 50, pp. 652-654, Apr. 2014.
- [10] J. Kim et al., "Coil design and shielding methods for a magnetic resonant wireless power transfer system," *Proceeding of the IEEE*, vol. 101, pp. 1332-1342, Jun. 2013.