

A Novel Antenna Achieving Null-less Magnetic Field Distribution for Near-field UHF RFID

Laiwei Shen¹, Wanchun Tang², Huiling Xiang¹, and Wei Zhuang²

¹Nanjing University of Science and Technology, Nanjing, China

²Nanjing Normal University, Nanjing, China

Abstract –In this paper, an antenna which can generate large, strong, and uniform magnetic field distribution is proposed for the near field magnetic coupling UHF RFID system. The antenna is composed of two elements and a feeding network. By feeding the two elements at different phases, their dead zones can be compensated by each other. Consequently, a uniform magnetic field distribution is achieved, which will be helpful in designing item level RFID system. And the perimeter of the interrogation zone is up to 5.4λ at 920MHz.

Index Terms — Near-field RFID, UHF, Uniform magnetic field distribution.

I. INTRODUCTION

Recently, ultra-high frequency (UHF) near-field radio-frequency identification (RFID) attracted a lot of attention since it greatly improves the reading stability by utilizing near field magnetic coupling. The most important task of the near-field RFID reader antenna is to generate a large, strong and uniform magnetic field near the antenna. For most commercial near field tags, the magnetic field normal to the surface of a commercial near field tag should be greater than -20dBm [1], [2].

Various near field RFID antennas are reported in [3]-[7]. Among them, antennas based on the phenomenon that two closely spaced oppositely directed currents (ODCs) can generate a strong magnetic near field between them has received much attention [5]-[7]. However, because the perpendicular magnetic field right above the current is in horizontal direction, there exist regions where perpendicular magnetic fields almost decline to null. These regions are called dead zones which will cause inconvenience in some applications.

In this paper, we proposed a new antenna to generate a uniform, strong magnetic field near the antenna. This

antenna is composed of two elements and a feeding network. Two elements of the antenna are designed as independent antennas separately based on the concept of ODCs as the antenna in [7]. The two elements are put together to achieve a null-less magnetic field distribution utilizing a feeding network which can provide 90° phase difference at two output ports. Design procedure and the performance of the antenna are shown in this paper.

II. ANTENNA CONFIGURATION AND PERFORMANCES

A. Antenna Configuration and Design Procedure

As shown in Fig.1, the proposed antenna is composed of two elements based on the concept of ODCs and a feeding network. For antennas using ODCs, the z-component magnetic field distribution of the two elements will experience several dead zones right above the current. But in this work, the two elements are put together and feed at different phases, and their dead zones are staggered and distributed at different locations. Consequently, the total magnetic field distribution will be null-less. The phase difference of the input RF signal of the two elements should be 90° to reduce the influence between the two elements. A feeding network similar to the feeding network of CP antennas is designed to achieve 90° phase difference. The antenna is printed on a $640\text{mm} \times 240\text{mm}$ FR4 substrate, the thickness is 1.6mm, and the relative dielectric is 4.4.

First, two elements are designed separately based on the concept of ODCs [8], and are referred as element 1 and element 2 in this literature, as shown in Fig. 1. The magnetic field distribution of them are illustrated in Fig. 2(a) and (b). It is obvious that both of the magnetic fields will have several dead zones (areas where perpendicular magnetic field strength is less than -20dBm , marked in dotted line rectangle

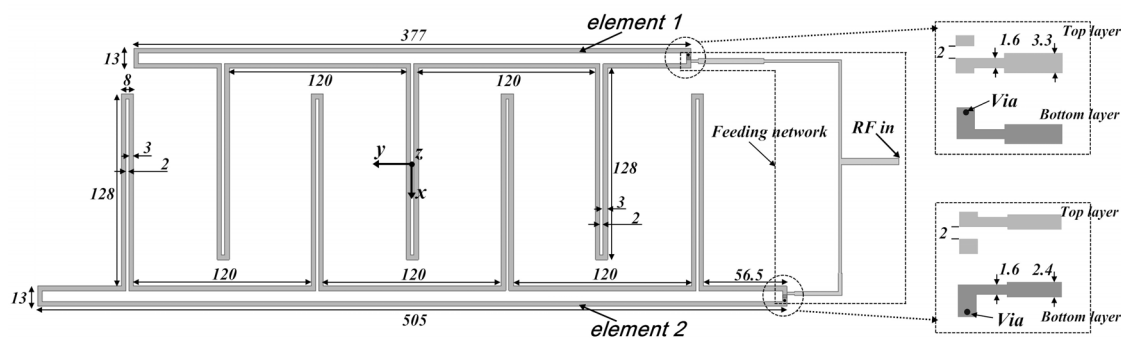

Fig. 1. Configuration and detailed dimensions of the proposed antenna (unit: mm).

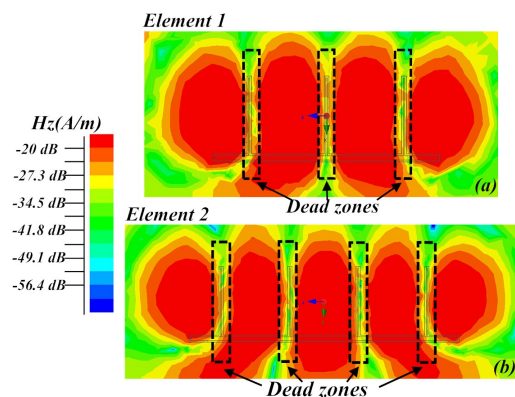

Fig. 2. Magnetic field distribution of (a) element 1 and (b) element 2 work independently ($z = 50\text{mm}$, Phase = 0°).

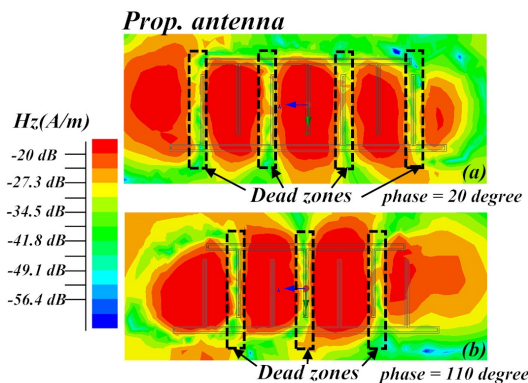

Fig. 3. Magnetic field distribution of the proposed antenna, two typical phases are shown here ($z = 50\text{mm}$, Phase = 20° , 110°).

in the figure), but distributed at different locations, and compensate each other. A quarter wavelength matching stub is employed to match the antenna to the feeding network.

Second, double-sided parallel-strip line (DSPSL) is selected as transmission line to construct the feeding network, and 90° phase lag is achieved by lengthen one of the output port by quarter wavelength. T junction is selected as the power divider.

Finally, the two elements are combined together using the feeding network. The optimized dimensions are listed in Fig. 1.

B. Magnetic Field Distribution and Return Loss

The field distributions of the proposed antenna at two typical phases are given in Fig. 3. When phase of input signal equals to 20° , the current on element 2 experiences its peak and the magnetic field is mainly generated by element 2, while element 1 is experiencing its valley point. When phase equals to 110° , the situation is the reverse: magnetic field distribution is dominated by current in element 1.

The maximum values of H_z through a period are plotted for comparison in Fig. 4. It is found that at several regions, the maximum z-components of magnetic field of the element 1 and element 2 are less than -20dBA/m , which indicates that tags distributed at these regions would not be “visible” to the reader. In contrast, almost all the maximum z-component of the proposed antenna (in solid line) is greater than -20dBA/m , which means that the dead zones are removed.

The return loss of the proposed antenna is plotted in Fig. 5. The bandwidth of the antenna is from 894MHz to 946MHz , which covers the common UHF RFID frequency bands.

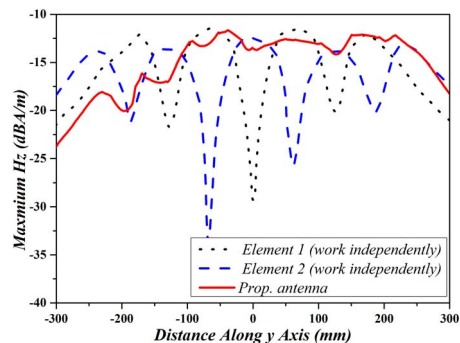

Fig. 4. Compare of maximum z-component magnetic fields of three antennas ($z = 50\text{mm}$, phase = whole periodic).

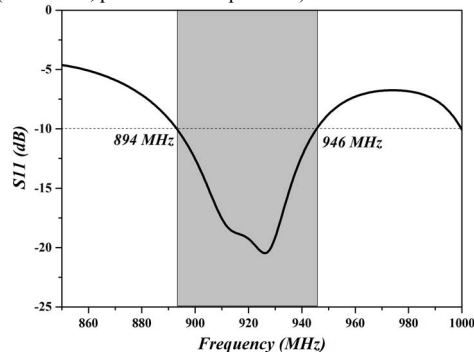

Fig. 5. The return loss of the proposed antenna

III. CONCLUSION

In this paper, we proposed a new null-less near field antenna for UHF RFID application based on the concept of ODCs. The two parts of the antenna work time-sharing by applying a phase lag feeding network, the dead zones of one element can be compensated by another. Consequently, a null-less magnetic field distribution is achieved, which will be helpful in designing item level RFID system. Besides, a more engineering-oriented method, one can make the two elements work time-sharing by employing a SPDT switch, which will further improve the performance of the antenna by eliminating the interferences between the two elements, this will be included in future investigation.

REFERENCES

- [1] Monza 2, <http://www.impinj.com/products/tag-chips.aspx>
- [2] Higgs 2, http://www.alientechnology.com/tags/rfid_ic.php
- [3] Xianming Qing, Chean Khan Goh, Zhi Ning Chen, “A broadband UHF near-field RFID antenna,” *IEEE Trans. on Antennas and Propagation*, Vol. 58, pp. 3829 - 3838, 2010. G. Maxwell, “Antennas and propagation in ISAP 2014,” in *Proc. IEEE Antennas Propagat. Soc. Int. Symp.*, 2012, Orlando, FL, USA, pp. 100-101.
- [4] Xiao Dong Wei, Bin Jie Hu, Hong Lin Zhang, “Novel UHF near-field RFID reader antenna based on double-sided parallel-strip line,” *IEEE Antennas and Wireless Propagation Letters*, Vol. 13, pp. 419-422, 2014.
- [5] Cho C., Ryoo J., Park I., Choo H., “Design of a novel ultra-high frequency radio-frequency identification reader antenna for near-field communication using opposite directed currents,” *IET Microwaves, Antennas & Propagation*, Vol. 4, pp. 1543 - 1548, 2010.
- [6] Chihyun Cho, Chuyong Lee, Jeongki Ryoo, Hosung Choo, “Planar near-field RFID reader antenna for item-level tagging,” *IEEE Antennas and Wireless Propagation Letters*, Vol. 10, pp. 1100-1103, 2011.
- [7] Xumin Ding, Qun Wu, Kuang Zhang, Chunnan Feng, “A magnetic coupling dipole for UHF near-field RFID reader,” *IEEE Trans. on Magnetics*, Vol. 48, pp. 4305-4308, 2012.