

A broadband duplexer design for a single balanced mixer application

Young-Gon Kim, Il-Heung Kang, Sung-Kyun Kim, Kang Wook Kim

College of IT Engineering, Kyungpook National University,

Sangyeok-dong, Buk-gu, Daegu, 702-701, Korea

Email : magon@ee.knu.ac.kr and kang_kim@ee.knu.ac.kr

Abstract

A broadband contiguous duplexer for a broadband single balanced mixer is presented. The duplexer is designed by combination of singly terminated low and high pass filters. The fabricated duplexer performs from DC to 4.6 GHz for low pass channel and 4.6 GHz to 18 GHz for high pass channel. For broadband high pass filter, broadside-coupling line is used. For low pass filter, high impedance lines without bottom conductor of the substrate are realized to obtain high values of inductance. The fabricated duplexer shows that insertion loss for low pass channel is less than 1 dB and high pass channel is less than 3 dB. More than 10 dB return loss is obtained for overall operating frequencies.

Keywords : Duplexer, balanced mixer, Low pass filter and High pass filter

1. Introduction

Microwave mixer is a fundamental component in many RF/microwave systems and is a standard component in wireless communications systems. It is a device that performs the task of frequency conversion, by multiplying two signals. In most cases, the mixer plays an important role in defining the overall performance of these systems. If port-to-port isolation is poor, unwanted signal might contaminate desired mixing signal and it could degrade system performance. However, there is always some amount of power leakage between LO, RF and IF ports. Variety researches have been carried out to enhance isolation. Well designed balun is recommended because mixer balancing offers inherent isolation between ports, cancelation of the most intermodulation products and improved conversion efficiency. Among many types of mixer, lots of single balanced mixers have been studied due to its simple design and good performance [1-2]. Single balanced mixers use 90° or 180° hybrid providing good isolation for the RF and LO ports. However, additional extraction circuit for IF is needed and external circuit should be added to obtain good isolation between IF and other ports. The bandwidth limited hybrids (balun) have been also used so that realization of broadband IF is difficult.

In this paper, we proposed the broadband duplexer for a single balanced mixer utilizing ultra-wideband balun to obtain ultra-wideband bandwidth [3]. The proposed duplexer is designed using high impedance lines without bottom conductor for low pass filter and broadside coupling to realize high values of capacitance for high pass filter. The fabricated duplexer exhibits low insertion losses and high isolation between two outputs.

2. Ultra-wideband single balanced mixer

The proposed broadband single balanced mixer is shown in Fig. 1. The diodes are connected in series to the CPS from ultra-wideband balun in parallel to CPW. (The diodes are installed at the intersection of the CPS and CPW). In this paper, the ultra-wideband balun is adopted to convert unbalanced signal to balanced signal at LO port. The proposed duplexer is connected for RF and IF ports. When the LO signal is applied to the diodes, balanced signal is excited at the diodes and LO signal is virtually terminated at diode junction on CPW signal line. Additionally balanced CPS signal is blocked due to unbalanced CPW mode. High isolation between LO and RF is obtained through this way. As an extra circuitry to enhance isolation between ports, we proposed

contiguous duplexer for RF and IF ports. The duplexer with transit frequency 4.6 GHz is designed to cover RF/LO frequency from 5 to 18 GHz and IF frequency from DC to 4 GHz.

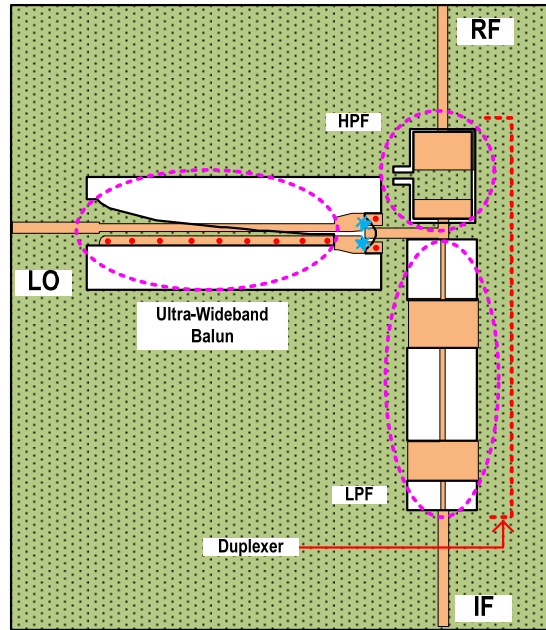

Figure 1: Proposed single balanced mixer using contiguous duplexer

3. Contiguous duplexer design

Proposed duplexer is designed by shunting low pass filter and high pass filter as shown in Fig. 2. Two filters should be matched at a common junction to minimize the reflection at port 1 (input) [4]. The sum of real value of admittances of two filters should be equal to the admittance of port 1. In the same way, the sum of imaginary values of two filters should be zero. LC-prototype of duplexer is designed based on the modified filter element values of 5th order singly terminated low pass filter and 3rd order singly terminated high pass filter. The values of duplexer lumped elements for the transit frequency 4.6 GHz is demonstrated in Fig. 2.

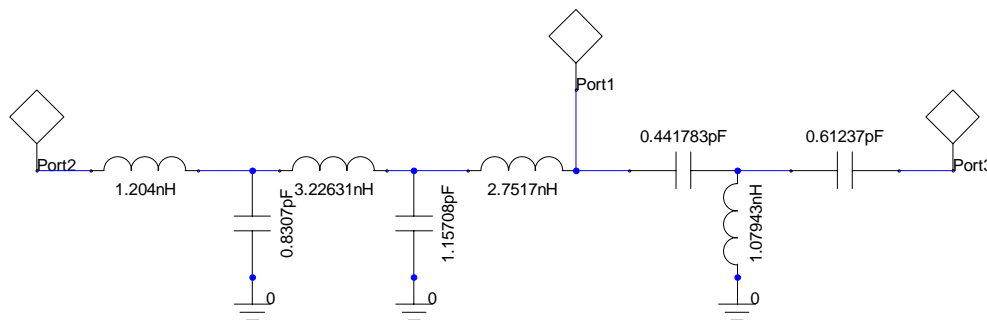

Figure 2: LC-prototype of duplexer

In this design, RT/Duroid 4003 with 8-mil thickness is used as a circuit substrate ($\epsilon_r=3.38$). The series inductance is realized by short high impedance lines without bottom conductor to obtain high impedance compared to having bottom conductor. The shunt capacitance is realized by low impedance lines. For a design of high pass filter, the design guideline in [5] is adopted. The series capacitance is obtained by broadside-coupled line because it is difficult for edge-coupled lines to realize high capacitance. The shunt inductance is made by short high impedance lines located on the bottom plane. The dimensions along with LC values are calculated by [4]. The two filters are connected with short lines as shown in Fig. 3. It is important for connection lines to have short lines to prevent short-circuiting the high pass by high admittance absolute values in the stop band of the

low pass due to phase progression [6]. The layout and dimensions of the duplexer are shown in Fig. 3.

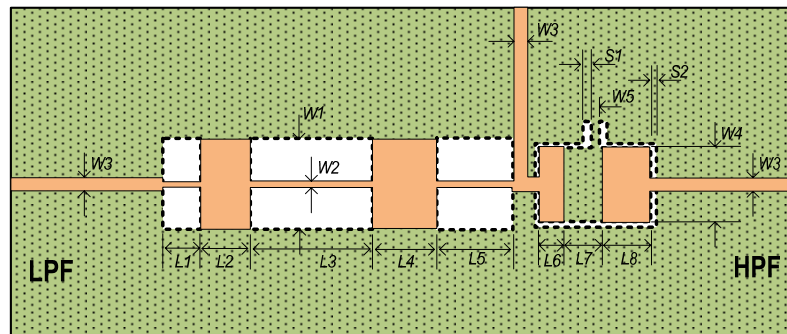
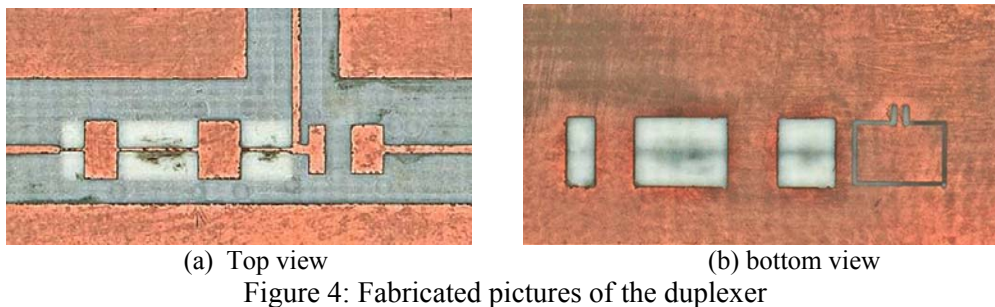

Figure 3: Layout of broadband duplexer. The dimensions are: $W1=120$ mil, $W2=8$ mil, $W3=18$ mil, $W4=100$ mil, $W5=10$ mil, $L1=50$ mil, $L2=66$ mil, $L3=160$ mil, $L4=85$ mil, $L5=100$ mil, $L6=34$ mil, $L7=50$ mil, $L8=65$ mil, $S1=10$ mil and $S2=5$ mil

Fig. 4 shows the top and bottom pictures of the fabricated duplexer. The performance of the duplexer was measured using the Anritsu network analyzer 37397C with the duplexer mounted in an Anritsu universal test fixture. Fig. 5 shows simulated and measured results. It shows good agreement between simulated and measured results. It is observed that measured insertion loss up to 4 GHz is less than 1 dB with more than 10 dB return loss for low pass channel. For frequencies from 5 to 18 GHz, measured insertion loss is less than 3 dB with more than 10 dB return loss. Higher insertion losses at high frequency may have been caused due to fabrication inaccuracy and the high loss tangent (loss tangent = 0.0027) of the substrate. Over 20 dB isolation is obtained within the operating frequencies.



(a) Top view
(b) bottom view
Figure 4: Fabricated pictures of the duplexer

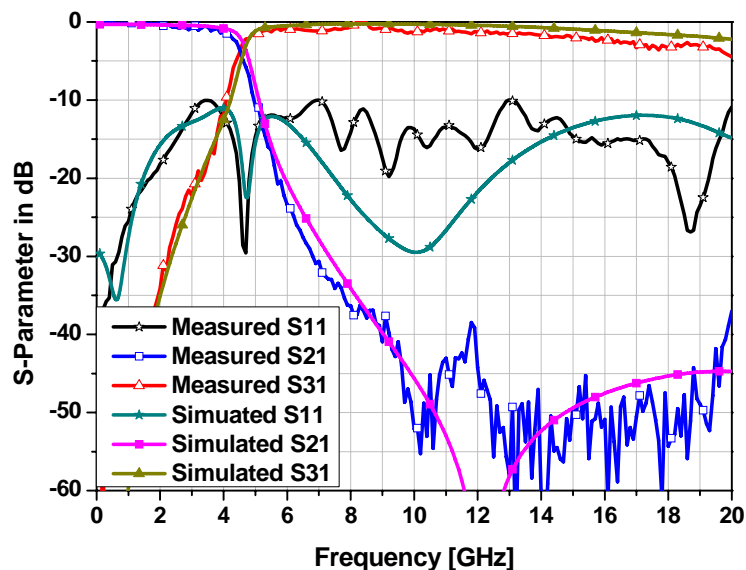

Figure 5: Measured and simulated return and insertion loss of the duplexer

4. Conclusion

A design method of broadband duplexer is introduced. The duplexer is combination of singly terminated low pass filter and high pass filter. The proposed duplexer provides low insertion loss, good return loss, high isolation and broad bandwidth. It is expected that the duplexer is applicable to a broadband single balanced mixer.

References

- [1] Jian Guo, Zhenbin Xu, Cheng Qian, Wenbin Dou, "A novel design of single balanced mixer for Ka-Band satellite transponder simulator," Microwave Conference, 2009. APMC 2009, Dec. 2009.
- [2] Man-Long Her, Phun-Fei Teo, Fan-Hsi Kung, Chi-Yuan Xie, Yu-Zhen Wang, Yi-Chyun Chiou, Yu-Lin Wang, Chun-Wei Kuo, "Design and analysis for three applications of 90-degree single balanced mixer," Communication Systems, 2002. ICCS 2002. The 8th International Conference on, Nov. 2002.
- [3] Y-G Kim, D. S. Woo, K. W. Kim, Y. K. Cho, "A new ultra-wideband microstrip-to-CPS transition," IEEE Int'l, Symp. Microwave., Honolulu, HI. pp. 1563-1566, Jun. 2007.
- [4] G. Matthaei, L. Young, and E. M. T. Jones, Microwave Filters, Impedance Matching Network, and Coupling Structures. Norwood, MA: Artech House, 1980.
- [5] M.C. Velazquez-Ahumada, Jesus Martel, Francisco Mediana, Francisco Mesa, "Design of Ultra-wide Bandpass filter Using Hybrid Microstrip/CPW structure," Microwave Conference, 2009. EuMC 2009. European Sept. 2009.
- [6] Robert. Rehner, Michael. Sterns, Drik Schneiderbanger, "A Quasi-Lumped Ultra-Broadband Contiguous SSL-Diplexer from DC to 80 GHz," Microwave Symposium Digest, 2009. Jun. 2009.

Acknowledgments

This research was supported by National R&D Program through the National Research Foundation of Korea (NRF) funded by the Ministry of Education, Science and Technology (2011-09160000).