

# Synchronization State of Coupled Changing Time Delayed Chaotic Circuits

Seiya Kita, Yoko Uwate and Yoshifumi Nishio

Department of Electrical and Electronic Engineering, Tokushima University  
 2-1 Minami-Josanjima, Tokushima 770-8506, Japan  
 Email: {kita,uwate,nishio}@ee.tokushima-u.ac.jp

**Abstract**—In this study, we investigate synchronization states observed in coupled time delayed chaotic circuits by inductor. Time delay of chaotic circuit depends on attractor types. We focus on relationships between synchronization state and time delay. Single type synchronization state can be observed by changing time delay of subcircuits. Co-existing synchronization states depending on initial values can be observed in specific time delay values. Moreover, we investigate the effect of various time delay values on the subcircuit to changing synchronization states.

## 1. Introduction

There are many nonlinear systems containing time delay, such as neural networks, control systems, meteorological systems, biological systems and so on in the natural world. Namely, it is considered that investigation of stability in such time-delay systems is important [1]. Generation of chaos of them all is reported self excited oscillation system containing time delay. This chaotic circuit can be easily realized by using simple electric circuit element and analyzed exactly [2]. There are examples of nonlinear phenomena, chaotic synchronization, clustering phenomenon and so on [3]. In particular, a number of studies on synchronization of coupled chaotic circuits have been made [4]. In previous study, we have investigated synchronization state observed in coupled time delayed chaotic circuits by inductor [5]. Coupled nonlinear circuits by inductor can be observed two types of synchronization states [6][7]. As a result, two types of synchronization state is caused by increasing the chaotic strength of subcircuit. In roughly divided, two types of synchronization states depending on initial values and number of subcircuits can be observed.

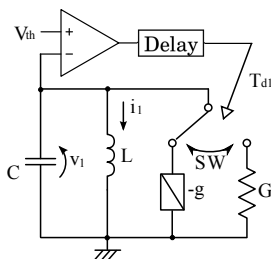

Figure 1: Time delayed chaotic circuit.

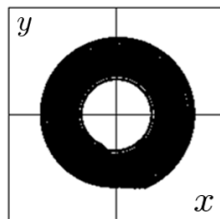

Figure 2: Chaotic attractor obtained by computer simulation.

Moreover, synchronization state can be classified by the number of coupled chaotic circuit whether the number is even or odd.

In this study, we investigate synchronization states by changing time delay of subcircuits in the proposed systems. The proposed systems denote coupled time delayed chaotic circuits by inductor as a bridge or a ring. By carrying out computer simulations, time delay of subcircuits effects a change synchronization state.

## 2. Circuit Model

Figure 1 shows the time delayed chaotic circuit. This circuit consists of one inductor  $L$ , one capacitor  $C$ , one linear negative resistor  $-g$  and one linear positive resistor  $R$  of which amplitude is controlled by the switch containing time delay. The current flowing through the inductor  $L$  is  $i$ , and the voltage between the capacitor  $C$  is  $v$ . The circuit equations are normalized as Eqs. (1) (2) by changing the variables as below.

(A) In case of switch connected to  $-g$ ,

$$\begin{cases} \dot{x} = y \\ \dot{y} = 2\alpha y - x. \end{cases} \quad (1)$$

(B) In case of switch connected to  $G$ ,

$$\begin{cases} \dot{x} = y \\ \dot{y} = -2\beta y - x. \end{cases} \quad (2)$$

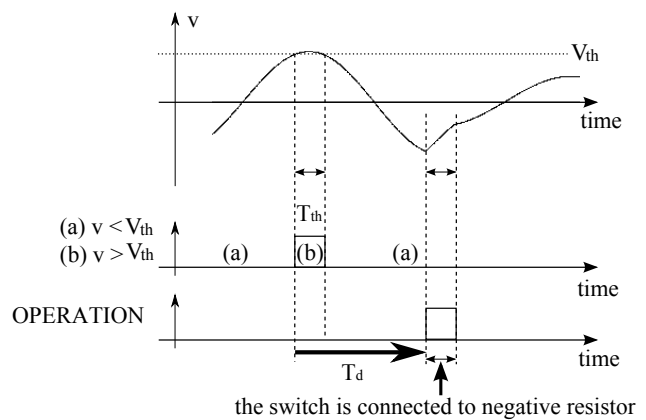

Figure 3: Switching operation.

By changing the parameters and variable as follow:

$$i = \sqrt{\frac{C}{L}} V_{th} x, v = V_{th} y, t = \sqrt{LC} \tau,$$

$$g \sqrt{\frac{C}{L}} = 2\alpha \text{ and } G \sqrt{\frac{C}{L}} = 2\beta.$$

Figure 2 is chaotic attractor observed from the circuit. The switching operation is shown in Fig. 3, it controls the amplitude of the oscillator. This switching operation is included time delay.  $T_d$  denotes the time delay. First, the switch is connected to a negative resistor. In state of that, the voltage  $v$  is amplified up to while  $v$  is oscillating, the amplitude exceeds the threshold voltage  $V_{th}$  which is the threshold control loop. Second, the system memorize the time as  $T_{th}$  while  $v$  is exceeding the threshold voltage  $V_{th}$  and that state is remained for  $T_{th}$ . In subsequent the instant of exceeding threshold  $V_{th}$ , the switch stays the state for  $T_d$ . After that switch is connected to positive resistor during  $T_{th}$ . The switch does not immediately connect in the positive resistor however the switch is connected after  $T_d$ . A set of switching operations control the amplitude of  $v$ . Figure 4 is bifurcation of time delayed chaotic circuit. By increasing the parameter value of time delay  $T_d$ , width of dot area changes. Time delayed chaotic circuit is changed time delay from  $\pi/2$  to  $3\pi/2$  in previous study [5]. In this study, we consider range of  $T_d$  is changed from  $5\pi/8$  to  $\pi$ . We investigate synchronization state when coupled of periodic attractor and chaotic attractor.

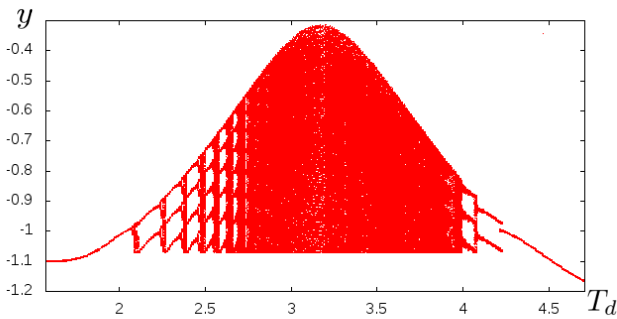

Figure 4: Bifurcation.  $T_d$  is variable.  $\alpha = 0.015$  and  $\beta = 0.8$ .

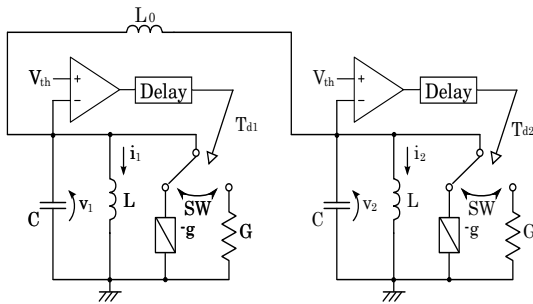

Figure 5: Coupled time delayed chaotic circuits.

### 3. Two Coupled Chaotic Circuits

Figure 5 shows the coupled chaotic circuit by inductor. The normalized circuit equations of the system are given as follows:

(A) In case of that switch is connected to  $-g$ ,

$$\begin{cases} \dot{x}_n = y_n \\ \dot{y}_n = 2\alpha y_n - x_n + \gamma(x_{n+1} - x_n). \end{cases} \quad (3)$$

(B) In case of that switch is connected to  $G$ ,

$$\begin{cases} \dot{x}_n = y_n \\ \dot{y}_n = -2\beta y_n - x_n + \gamma(x_{n+1} - x_n). \end{cases} \quad (4)$$

where  $(n = 1, 2)$  and  $x_3 = x_1$ . By changing the parameters and variable as follow:

$$i_n = \sqrt{\frac{C}{L}} V_{th} x_n, v_n = V_{th} y_n, t = \sqrt{LC} \tau,$$

$$g \sqrt{\frac{C}{L}} = 2\alpha, G \sqrt{\frac{C}{L}} = 2\beta \text{ and } \gamma = \frac{L}{L_0}.$$

We investigate the synchronization when time delay  $T_{d1}$  and  $T_{d2}$  of chaos circuits are changed from 1.96 to 3.14. Figure 7 shows some of simulation results. Table 1 shows the synchronization states each time delay. When  $(T_{d1}, T_{d2}) = (1.96, 3.14)$ , coexisting in-phase synchronization and anti-phase synchronization state can be observed depending on initial values. By increasing  $(T_{d1}, T_{d2}) = (2.60, 3.14)$  or  $(T_{d1}, T_{d2}) = (3.14, 3.14)$ , synchronization state is fixed anti-phase synchronization. In-phase synchronization is readily induced when  $T_d$  is small.

### 4. A Ring of Three Coupled Chaotic Circuit

Figure 6 shows the schematic of a ring of three coupled time delayed chaotic circuits coupled by the inductor. The normalized system equations are given as follows:

(A) In case of switch connected to  $-g$ ,

$$\begin{cases} \dot{x}_n = y_n \\ \dot{y}_n = 2\alpha y_n - x_n - \gamma(2x_n - x_{n+1} - x_{n-1}). \end{cases} \quad (5)$$

(B) In case of switch connected to  $G$ ,

$$\begin{cases} \dot{x}_n = y_n \\ \dot{y}_n = -2\beta y_n - x_n - \gamma(2x_n - x_{n+1} - x_{n-1}). \end{cases} \quad (6)$$

where  $(n = 1, 2, 3)$ ,  $x_0 = x_3$  and  $x_4 = x_1$ .

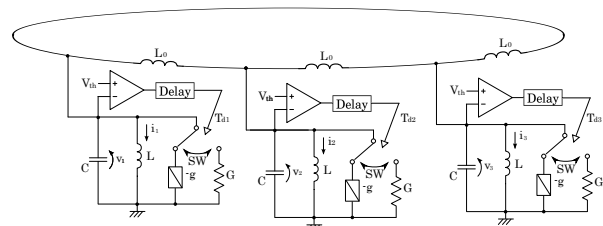
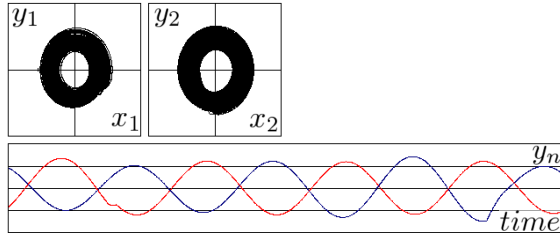
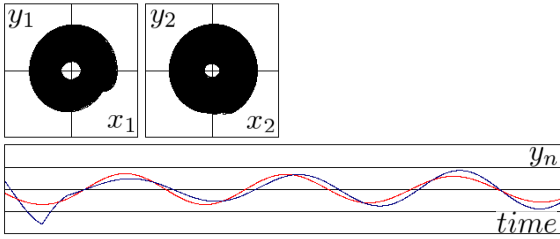

Figure 6: A ring of three coupled time delayed chaotic circuits.



(1) In-phase synchronization state  $T_{d1} = 3.14$  and  $T_{d2} = 1.96$ .



(2) Anti-phase synchronization state  $T_{d1} = 3.14$  and  $T_{d2} = 1.96$ .

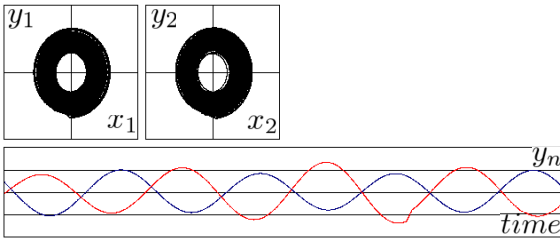

(3) Anti-phase synchronization state  $T_{d1} = 3.14$  and  $T_{d2} = 3.14$ .

Figure 7: Simulation results of bridge chaotic circuits. Attractor. Time waveform. Red and blue colors denote  $y_1$  and  $y_2$  respectively.

We investigate the synchronization when three chaos circuits are changed time delay range from 1.96 to 3.14. Table 2 shows synchronization states. We observed the two types of synchronization state. Figure 8 shows some of simulation results. Switching synchronization states can be observed as shown in time waveform of Fig. 8 (1). Switching synchronization state is constituted anti-phase synchronization and three-phase synchronization state. However only three-phase synchronization state can be observed as shown in time waveform of Fig. 8 (2). When anti-phase synchronization state is observed, single voltage amplitude of subcircuits 1 or 2 becomes about zero for only a moment.

## 5. Conclusions

In this study, we have investigated synchronization state observed in two coupled variable time delayed chaotic circuits by inductor. As a result, when time delay is small, in-phase synchronization state can be observed. However induction of anti-phase synchronization state caused by increasing time delay to 3.14 of subcircuit has confirmed. Furthermore, we have investigated synchronization state observed on a ring of three coupled variable time delayed chaotic circuits by inductor. As a result, induction of three-phase synchronization caused increasing time de-

Table 1: Synchronization state  $N = 2$ .

Timedelay		Synchronization state	
$T_{d1}$	$T_{d2}$	In -phase	Anti-phase
1.96	1.96	○	
	2.20	○	
	2.35	○	
	2.40	○	
	2.52	○	
	2.60	○	
2.20	3.14	○	○
	2.20	○	
	2.35	○	
	2.40	○	
2.35	2.52	○	
	2.60	○	
	3.14	○	
	2.40	○	
2.40	2.52	○	
	2.60	○	
	3.14	○	
2.52	2.52	○	
	2.60	○	
	3.14	○	
2.60	2.60	○	
	3.14		○
3.14	3.14		○

Table 2: Synchronization state  $N = 3$ .

Timedelay		Synchronization state		
$T_{d1}$	$T_{d2}$	$T_{d3}$	Three-phase	Switching
3.14	3.14	1.96		○
		2.20		○
		2.35		○
		2.40		○
		2.52	○	
		2.60	○	
		3.14	○	

lay to 3.14 of subcircuit has confirmed. However switching synchronization state can be observed when single time delay of subcircuits is too small. Moreover, switching synchronization state is constituted anti-phase synchronization and three-phase synchronization states when a ring of three coupled time delayed chaotic circuits.

## References

- [1] X. Liu, "Stability of impulsive control systems with time delay. Mathematical and Computer Modelling,"

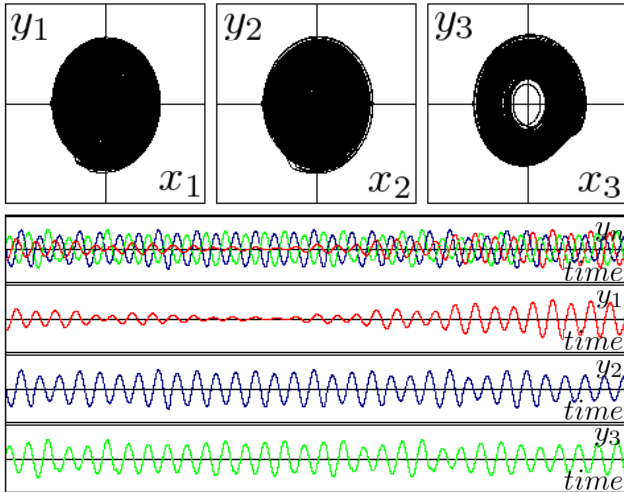

(1) Switching synchronization state  $T_{d1} = 3.14$ ,  $T_{d2} = 3.14$  and  $T_{d3} = 1.96$ .

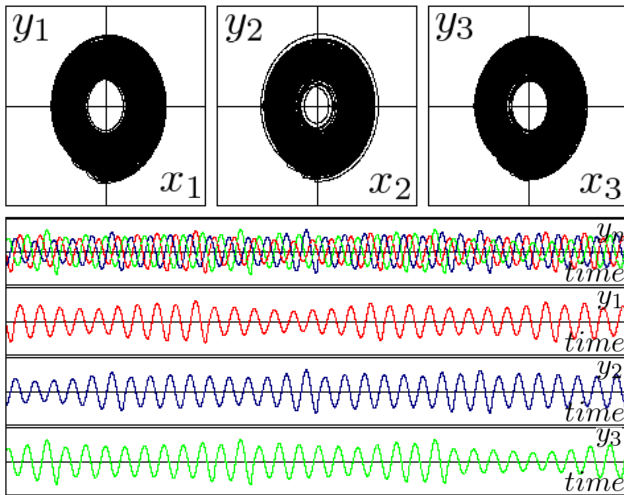

(2) Anti-phase synchronization state  $T_{d1} = 3.14$ ,  $T_{d2} = 3.14$  and  $T_{d3} = 3.14$ .

Figure 8: Simulation results of a ring coupled three chaotic circuits. Attractor. Time waveform. Red, blue and green colors denote  $y_1$ ,  $y_2$  and  $y_3$  respectively.

Vol.39, pp.511-519, 2004.

- [2] T. Maruyama, N. Inaba, Y. Nishio and S. Mori, "Chaos in an Auto Gain Controlled Oscillator Containing Time Delay," Trans. IEICE, vol. J 72-A, pp. 1814-1820, Nov. 1989.
- [3] T. Maruyama, N. Inaba, Y. Nishio and S. Mori, "Chaos in Self Oscillator Circuit Containing Time Delay," Proceedings of IEEE Midwest Symposium on Circuits and Systems (MWSCAS'90), vol. 2, pp. 1055-1058, Aug. 1990.
- [4] L. M. Pecora and T. L. Carroll, "Synchronization in Chaotic Systems," Physical Review Letters, vol. 64, no.8, pp. 821-824, Feb. 1990.

- [5] S. Kita, Y. Uwate and Y. Nishio, "Synchronization State of Coupled Chaotic Circuits Containing Time Delay," Proc. NOMA'15 (accepted).
- [6] M. Wada, Y. Nishio and A. Ushida, "Analysis of Bifurcation Phenomena in Two Chaotic Circuits Coupled by an Inductor," IEICE Transactions on Fundamentals, vol. E80-A, no. 5, pp. 869-875, May. 1997.
- [7] M. Wada, Y. Nishio and A. Ushida, "Wave Propagation Phenomena of Phase States in Oscillators Coupled by Inductors as a Ladder," IEICE Transactions on Fundamentals, vol. E82-A, no. 11, pp. 2592-2598, Nov. 1999.