

Self-Sustained Oscillation in Half Bridge Circuit of Silicon Carbide Devices with Inductive Load

Tatsuya Yanagi[†], Hiroataka Otake[†], Ken Nakahara[†] and Takashi Hikiyama[‡]

[†]Power Application Development Division, ROHM Co., Ltd.
 21 Mizosaki-cho, Ukyo, Kyoto, 615-8585, Japan
[‡]Department of Electrical Engineering, Kyoto University
 Katsura, Nishikyo, Kyoto, 615-8510, Japan
 Email: tatsuya.yanagi@dsn.rohm.co.jp

Abstract– This paper discusses self turn-on and its consequence of self-sustained oscillations observed in a half-bridge configuration of SiC (Silicon Carbide) MOSFETs in experiments and circuit simulation. The oscillation is triggered by self turn-on at the non-driven device, due to its large feedback capacitance and relatively low threshold voltage. The generated oscillation seems to be maintained by feed through resonance caused by parasitic inductances and capacitances. We do circuit simulation for the oscillation, and discuss how the oscillation develops and the trajectory of non-driven device moves.

1. Introduction

Recently, the development of wide band gap materials, such as Silicon Carbide (SiC) and Gallium Nitride (GaN) power devices, are at the phase of application into devices taking advantage of their physical characteristics. The device can be designed based on the withstanding voltage. It implies that a thin drift layer leads to a low on-state resistance (R_{on}). It also allows smaller chips without reducing current-carrying capacity[1]. Small chips produce small input capacitance (C_{iss}), facilitating high speed switching. Conversely the thin drift layer leads to close separation of the gate and drain electrodes and results large feed-back capacitance (C_{rss}).

Two serial connected transistors configuration, constituting a half-bridge (HB) is a typical circuit configuration in power electronics. In a HB, the serially connected transistors often form a short-circuit caused by unintentional turn-on[2, 3]. This phenomenon is called self turn-on[3], and periodically occurs as a so called as self-sustained oscillation under certain conditions[4 - 6]. In this paper the oscillation is called a self-sustained oscillation.

This paper discusses self turn-on and the consequential self-sustained oscillations observed in a HB configuration with SiC MOSFETs (metal-oxide-semiconductor field-effect transistors) in experiments and circuit simulation. The experimental circuit configuration and setups are described in section 2, and the experimental results are provided in section 3. In section 4, the authors show that circuit simulation reflects well the experimental results and the mechanism of the self sustained oscillation are

discussed. The experimental $I_d - V_d$ trajectory is displayed in section 5 to discuss the oscillation from a different point of view, and finally we conclude the paper in section 6.

2. Circuit configuration and setup

2.1. HB configuration with SiC MOSFETs

Here are introduced a switching circuit with a HB geometry with an inductive load. SiC MOSFETs with trench-gate structure are adopted for the experiments in this paper. The C_{rss}/C_{iss} value of the device is double of Si devices. We have found that a relatively large C_{rss} of SiC MOSFETs actually enhances the possibility of self turn-on and self-sustained oscillation in a HB configuration.

Figure 1 shows the schematic diagram of the circuit. In the figure, HS denotes the MOSFET on the side with directly fed input voltage and LS is the other device on the ground side. The HS and LS each consist of a single bare-die SiC MOSFET attached to a direct bond copper substrate with solder.

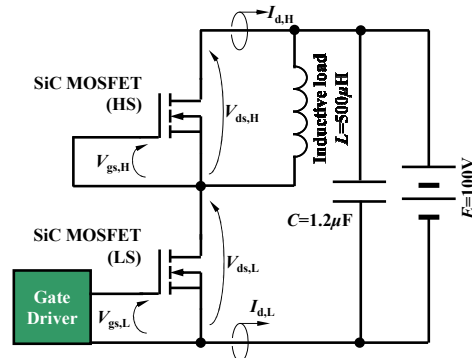

Figure 1: Experimental circuit configuration

2.2. Experimental setup

The gate driver drove LS applying +18 V/0V square pulses with a 50% duty cycle and a frequency of 120 kHz. HS worked as the freewheeling device with its gate and source comprising a short circuit. The inductive load is connected between the drain and the source of HS. The measured voltages at 4 nodes and the currents at 2 branches are measured as shown in Fig.1. E denotes the

voltage of the source supply with 100V. In measurement, $V_{ds,H}$ and $V_{ds,L}$ are obtained by differential probe, YOKOGAWA 700924. $V_{gs,H}$ and $V_{gs,L}$ are detected by use of differential probe, YOKOGAWA 700921. $I_{d,H}$ and $I_{d,L}$ are measured by using a Rogowskii coil type current probe, PEM CWT mini.

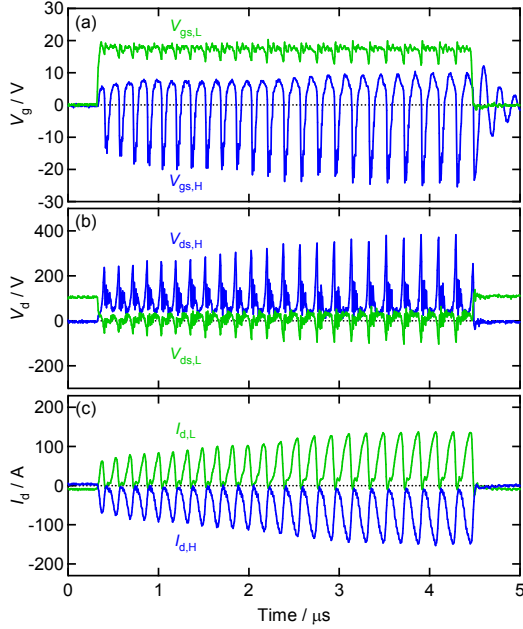

Figure 2: Self sustained oscillation observed in experimental V_g , V_d and I_d during LS turn-on.

3. Experimental results

Figure 2 shows how HS and LS behave when $V_{gs,L}$ is applied. When the switch is turned on, $V_{gs,L}$ goes up to +18V, and $V_{gs,H} = 0$ V, $V_{ds,L} = 0$ V, and $V_{ds,H} = 100$ V will be achieved. Unanticipated oscillations, however, are definitely observed in the experimental results as in Fig.2 (a)-(c) through on-state of HS device. In particular, the current waveforms in Fig.2 (c) show that the same amount of current flows through HS and LS. The current indicates that the short circuit formed by HS unintentionally turns on in spite of HS intending to maintain off-state when LS turns on. The unintentionally turn-on is caused by unexpected current through C_{rss} of HS occurred by high $dV_{ds,H}/dt$. After that, the current through C_{rss} charges C_{iss} of HS, entailing that $V_{gs,H}$ exceeds the gate threshold voltage ($V_{th} \sim 2.8$ V) of HS. The waveform of $V_{gs,H}$ in Fig.2 (a) shows that $V_{gs,H}$ exceeds the gate threshold voltage. The vibrations gradually develop during on-state of LS and finally stop increasing in amplitude. The oscillation ceases when LS turns off. The oscillation is so called as self-sustained oscillation[4 - 6].

4. Simulation of self-sustained oscillation

4.1. Circuit simulation including parasitic inductances

LTspice was used to simulate the experimental circuit by use of a VDMOS model [7] to represent the static characteristics of the SiC MOSFET. The parameters to set up the model are listed in Table 1. The V_{to} parameter to determine the threshold voltage of a SiC MOSFET (V_{th}), however, inevitably contains ambiguity to some extent, because it is very difficult to determine V_{th} due to the shape of I_d-V_g curve of a SiC MOSFET around $V_g \sim V_{th}$. [8] The simulation implemented by use of the circuit in Fig.1 provides the ideal waveforms, if parasitic inductances in the circuit are not taken into account. Accordingly the authors added parasitic inductance in the power loop (loop A) and the signal loop (loop B) as drawn in Fig.3. These parasitic elements completely change the simulation results, and the simulated waveforms coincide well with the experimental results of self-sustained oscillation. Fig. 4 shows a single cycle of the oscillation in experiments and circuit simulations. The total inductance value in loop A is determined by the slope of the short-circuit current obtained based on experimental data explained in the next section. On the other hand, the parasitic inductance in loop B is adjusted so as to reproduce the experimental results because of inevitably undetermined factors in V_{th} as mentioned above in spite of its very important role in producing self-oscillations discussed here. Thus we take the option of putting the very large parasitic inductance in loop B to compensate the uncertainty of V_{th} .

R_g	2.0 Ω	C_{gs}	650 pF
V_{to}	2.8 V	C_{jo}	900 pF
R_d	0.0 Ω	I_s	90 pA
R_s	0.0 Ω	V_{ds}	1200 V
K_p	8.0 A/V ²	R_{on}	40 m Ω
C_{gdmax}	1.25 nF	Q_g	120 nC
C_{gdmin}	20 pF		

Table 1: Parameters of VDMOS model of SiC MOSFET using in simulation

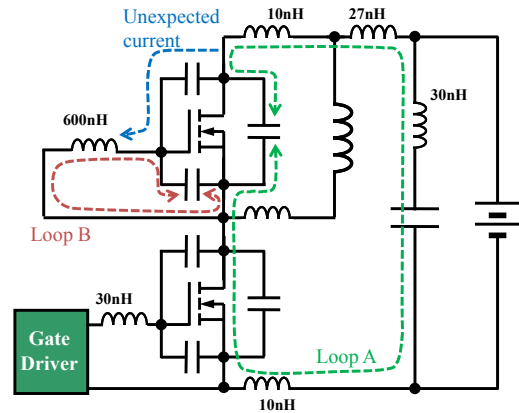

Figure 3: Schematic circuit for simulation with parasitic inductances

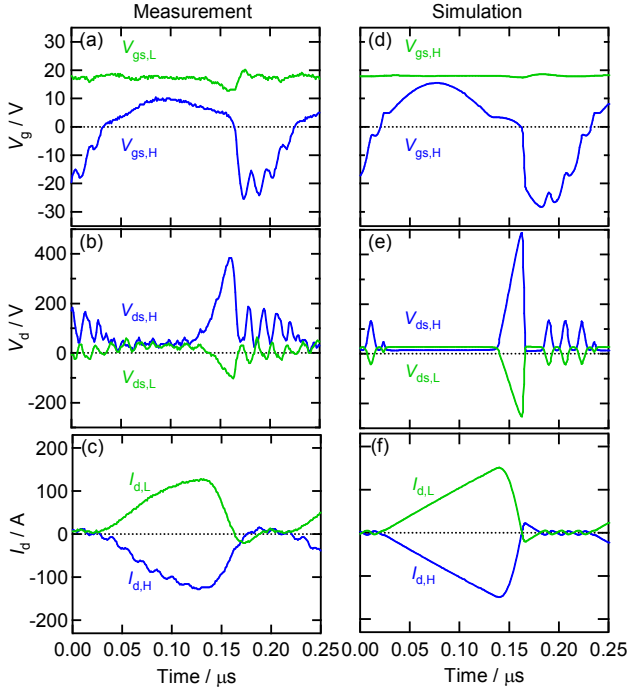

Figure 4

- (a)-(c): Single-cycle of experimental self sustained oscillation waveforms
 (d)-(f): Single-cycle of simulated self sustained oscillation waveforms

4.2. Simulation using a simplified circuit and the mechanism of self-sustained oscillation

The team tried to simplify the circuit generating oscillation in order to clarify the minimum factors which reproduce the observed oscillations. LS is replaced by a pure resistor with 80 mΩ, which is equal to the R_{on} value of LS, because LS maintains on-state as shown in Fig.2 (a). $I_{d,L}+I_{d,H}$ is almost zero, indicating that the oscillation current flows through loop A, and thus the inductive load is ignorable. Finally the circuit is simplified to the one shown in Fig. 5.

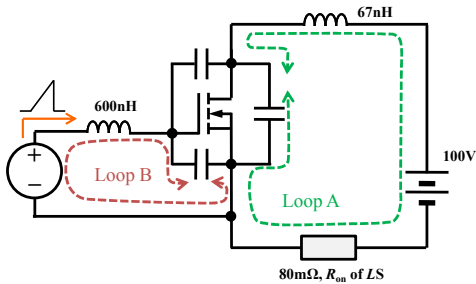

Figure 5: Simplified circuit for simulation

A single triangle pulse exceeding V_{th} is applied to the gate of HS just once in this simplified circuit. The simulated results are shown in Fig.6. The simulated results for the simplified circuit produce waveforms very similar

to the self-sustained oscillations, as clearly seen in Fig.6. This coincidence elucidates that self turn-on at HS initiates the self-sustained oscillation, and hence we can substantially discuss the mechanism of the self-sustained oscillations based on the circuit of Fig.5.

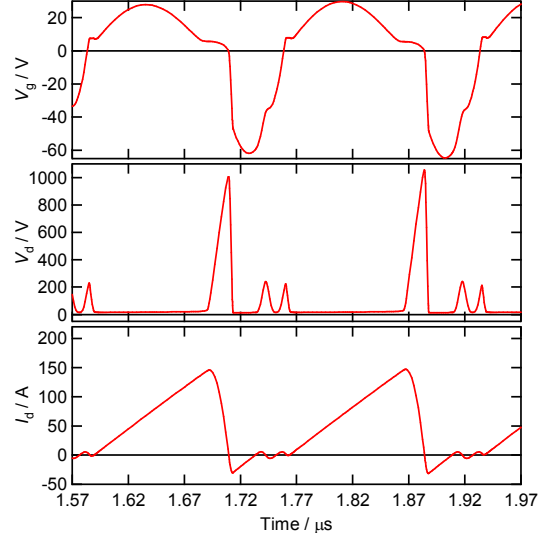

Figure 6: Simulated waveforms using the simplified circuit displayed in Fig.5

We explain how the self-sustained oscillation develops after self-turn of HS as follows:

(Phase-1) The self-turn on at HS is the beginning of all the following circuit behaviors. When LS turns on, $V_{gs,H}$ shoots up from 0 to E with high dV/dt due to the high switching speed of a SiC MOSFET. High dV/dt lowers the impedance of C_{rss} , so that unexpected current flows through C_{rss} and then charges C_{iss} . Charged C_{iss} raises $V_{gs,H}$ and finally HS unintentionally turns on when $V_{gs,H}$ reaches the V_{th} of HS. Both HS and LS become on, and current inevitably starts to flow through HS and LS ($I_{d,L} = -I_{d,H}$), as you can see in Fig.4 (f).

(Phase-2) The short-circuit current flows along loop A, so that power supply E is applied to the total parasitic inductance. Thus $I_{d,L}$ linearly increases with E/L_s in Figs.4 (f). L_s denotes the total parasitic inductance along loop A (67nH).

(Phase-3) $I_{d,L}$ does not infinitely increase because of the saturation current of a SiC MOSFET. When $I_{d,L}$ reaches the saturation current, the electromotive force of L_s is zero due to $dI_{d,L}/dt=0$. Thus E is directly applied to HS, and $I_{d,L}$ inevitably flows into parasitic capacitances of HS. Consequently $V_{ds,H}$ increases as shown in Fig.6.

(Phase-4) $I_{d,L}$ decreases and finally reaches 0 A. The charge of parasitic capacitances of HS decreases and $I_{ds,L}$ flows in the opposite direction in Fig.4 (f). Discharging C_{iss} finally turns HS off, and then the RLC resonance in loop A begins as you can see relatively small peak and valley waveforms appear in Figs. 4 (d)-(f). The resonance is superimposed on the on-going RLC resonance in loop B. (Phase-5) The RLC resonance in loop B pushes $V_{gs,H}$ over the V_{th} of HS again. Then the circuit operation returns to (1) and the oscillation continues.

5. Trajectory of self turn-on and self-sustained oscillation

Figure 7 presents the $I_d - V_d$ trajectory of experimental $-I_{ds,H}$ and $V_{ds,H}$ of HS to analyze the self-sustained oscillation. The current and voltage do not show the coincidence at their beginning due to a different delay time of the measurement probes. Here they are given a time offset $dV_{ds,L}/dt = 0$ for adjustment at $I_{d,L}=0$. It is because the waveforms of $V_{ds,L}$ depend on the self-induced electromotive force of the parasitic inductance in the copper substrate between the differential probes.

The first cycle of the self-sustained oscillation rotates as shown by dashed lines A, B, C and D. HS first stays around the origin of the trajectory plane before LS turns on. After self turn-on at HS, both $-I_{ds,H}$ and $V_{ds,H}$ linearly increase, as indicated by line A. The operating point moves along the static $I_d - V_d$ characteristic as indicated by black solid line in Fig.7. This reveals that the initial stage of the self-sustained oscillation is governed by the static $I_d - V_d$ characteristics.

The trajectory changes the direction when $-I_{d,H}$ reaches the saturation current of HS. Thereby $-I_{d,H}$ decreases accompanying with $V_{ds,H}$ surge. As a result, the trajectory proceeds downwards as indicated by line B. The trajectory along dashed line B depends on RLC resonance in loop A. Finally the trajectory reaches the zero current line, and then proceeds, as indicated by line C, to converge to the ideal off-state equilibrium that $V_{ds,H}=100V$ and $-I_{d,H}=0A$ are satisfied. The trajectory along dashed line C which rotates around the off-state equilibrium depends on LC resonance between L_s and the drain-to-source capacitance of HS in loop A.

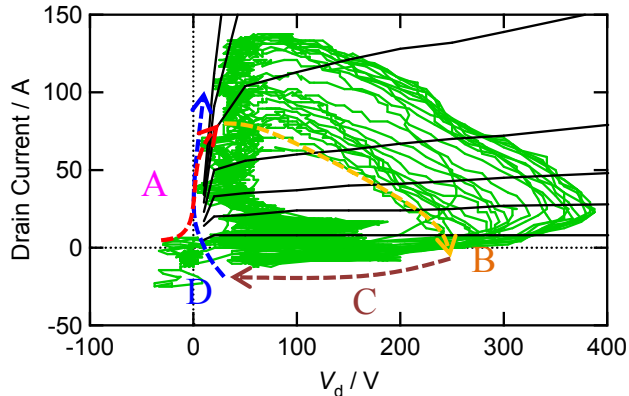

Figure 7: $I_d - V_d$ trajectory of HS at the sustained oscillation. Black solid lines for presents static $I_{ds,H} - V_{ds,H}$ characteristics of HS SiC MOSFET.

The resonance in loop B is generated by the gate-to-source capacitance of HS and the parasitic inductance. The resonance eventually pushes $V_{gs,H}$ over V_{th} . Consequently the trajectory heads for the area of high current and low voltage along the line D by the static $I_d - V_d$ characteristics.

The current flowing in loop A partly goes into loop B. It implies the electrical energy accumulated in loop B

increases the area of the closed loop of trajectory. Thus the area of a trajectory cycle increases as the cycle proceeds. This explanation does not complete with comparison to the results of experiments.

6. Concluding remarks

In this paper the experimental self-sustained oscillation is discussed for the high speed switching operation of a HB circuit of two SiC MOSFETs with inductive load. The phenomenon could be reproduced through the simulation by LTspice when considering parasitic components. The simulated results give a possibility of the self-sustained oscillation. This oscillation seems triggered by self turn-on at HS and developed by RLC resonances in the power line loop and the signal line loop. The $I_d - V_d$ trajectory analysis also clarifies that the initial and final stage of the oscillation are governed by the static $I_d - V_d$ characteristics. The mechanism is not confirmed exactly in this report. A clear understanding of circuit behavior will aid in the design of high switching frequency power circuits. Research in this area is not yet mature and must be continued.

References

- [1] B. J. Baliga, "Silicon Carbide Power Device," Singapore, World Scientific Publishing Co.Pte. Ltd, pp. 221-257, 2005.
- [2] N. Mohan, T. M. Undeland and W. P. Robbins, "Power Electronics Converters, Applications and Design," 3rd ed. New Jarsey, John Wiley & Sons, INC., pp. 629-640, 2003.
- [3] T.Funaki "A study on self turn-on phenomenon in fast operating of high voltage power MOSFET" *IEEE IPMT Symposium JAPAN*, 2013.
- [4] A.Lemmon, J.Gafford and C.Parker, "Instability in Half-Bridge Circuit Switched With Wide Band-Gap Transistor" *IEEE Trans. Electron. Dev.*, vol. 29, no5, pp2380-2392, 2014.
- [5] J.Colmenares, D.Peftitsis, J.Rabkowski, D.P.Sadik and P.Nee "Dual-Function Gate Driver for a Power Module With SiC Junction Field-Effect Transistor" *IEEE Trans. Electron. Dev.*, vol. 29, no5, pp2367-2379, May, 2014.
- [6] T.Yanagi, H.Otake and K.Nakahara "The Mechanism of Parasitic Oscillation in a Half Bridge Circuit Including Wide Band-gap Semiconductor Devices", *IEEE Future of Electron Devices Kansai*, 2014
- [7] M. Broadmeadow, "Characterisation of the cascode gate driver of power MOSFETs in clamped inductive switching applications", Queensland University of Technology, Australia, Ph.D. thesis, 2015.
- [8] ROHM Co., Ltd., "N-channel SiC power MOSFET" SCT2080KE datasheet, Jan. 2014.