

A discrete-time control approach for stabilizing unknown steady state of chaotic systems

Tadashi Tsubone, Kenichi Kurimoto and Yasuhiro Wada

Nagaoka University of Technology
 1603-1 Kamitomioka-cho, Nagaoka-shi, Niigata, 940-2188, Japan
 Email: tsubone@vos.nagaokaut.ac.jp

Abstract—A discrete-time control system with dynamic states for stabilizing unknown unstable fixed points of nonlinear systems is introduced. The control method is based on a discrete-time system which corresponds to an embedded return map derived from the continuous-time dynamics of the nonlinear systems. The discrete-time approach allows to stabilize unknown unstable fixed points of the return maps. In this paper, we show that our control method can stabilize unknown unstable periodic orbits of chaotic spiking oscillators.

1. Introduction

In this study, we focus on procedures to stabilize an Unstable Periodic Orbit (abbr. UPO) which are embedded on a chaos attractor. The procedures are called Controlling Chaos [1]. As is well known, Ott, Grebogi and Yorke (ab. OGY) have firstly introduced a technique that can stabilize an UPO embedded in a chaotic attractor through perturbations in system parameters[1]. The OGY method uses a knowledge of linear approximation near the desired UPO. Also, Pyragas [2] introduced an useful controlling chaos method which utilizes an information of delay time, the method is called Delayed Feedback Control (abbr. DFC). DFC has advantages such that no preliminary calculation of the UPO and no linear approximation around the UPO is required in order to stabilize the UPO.

We provide a design procedure of a controlling circuit which can stabilize of various periodic solutions based on UPOs embedded on a chaos system. Our proposed method effectively performs controlling chaos and has the some advantage as DFC, that is, no preliminary calculation of the UPO is required. And our control procedure is similar to some nonlinear approach to treat unknown steady state, washout filter-aided control [3], stability transformation [4].

In this paper, we use an example of chaos generator in order to explain the control method. The chaos generator is a simple chaotic spiking oscillator. Chaotic spiking oscillators have been studied in many interesting works[5][6], because these are included in hybrid dynamical systems with various bifurcation phenomena. We show some theoretical result for stability analysis.

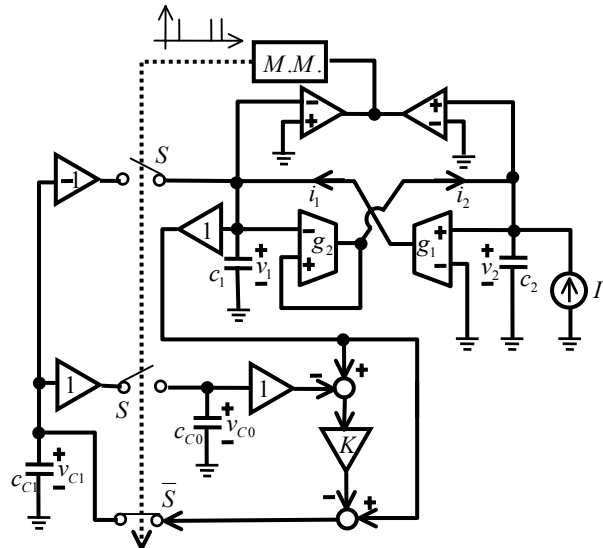

Figure 1: An implementation example of the chaos generator.

2. A simple chaotic spiking oscillator

2.1. Circuit and dynamics

Figure 1 shows a circuit model of the simple chaotic spiking oscillator, where we consider the case of $K = 0$ in this section. g_1 and g_2 are differential voltage-controlled transconductance amplifiers and their output currents are i_1 and i_2 , respectively, which can be characterized by

$$\begin{pmatrix} i_1 \\ i_2 \end{pmatrix} = \begin{pmatrix} 0 & g_1 \\ -g_2 & g_2 \end{pmatrix} \begin{pmatrix} v_1 \\ v_2 \end{pmatrix} \quad (1)$$

Connecting two capacitors to both output terminal of the conductance amplifiers, we obtain a two dimensional linear system. When S is opened, the circuit dynamics is described by

$$\begin{pmatrix} C_1 \frac{dv_1}{dt} \\ C_2 \frac{dv_2}{dt} \end{pmatrix} = \begin{pmatrix} 0 & g_1 \\ -g_2 & g_2 \end{pmatrix} \begin{pmatrix} v_1 \\ v_2 \end{pmatrix} + \begin{pmatrix} 0 \\ I \end{pmatrix}, \quad (2)$$

where I is a constant current.

Using the following dimensionless variables and parameters:

$$\begin{aligned} \tau &= \sqrt{\frac{g_1 g_2}{C_1 C_2}} t, & x &= \frac{g_2}{I} v_1, \\ y &= \frac{g_2}{I} \sqrt{\frac{C_2 g_1}{C_1 g_2}} v_2, & 2\delta &= \sqrt{\frac{C_1 g_2}{C_2 g_1}}, \end{aligned} \quad (3)$$

Equation (2) is transformed into

$$\begin{cases} \dot{x} = y, \\ \dot{y} = 2\delta y - x + 1, \end{cases} \quad (4)$$

where “.” represents the derivative of τ . We assume the following parameter condition

$$0 < \delta < 1. \quad (5)$$

In this case, Equation (7) has unstable complex characteristic roots $\delta \pm j\omega$ where $\omega = \sqrt{1 - \delta^2}$. The trajectory moves around the equilibrium point $(1, 0)$ divergently and it must reach to fourth quadrant from $x < 0$ and $y = 0$ as shown Fig. 2.

In this circuit in Fig. 1, *M.M.* is a monostable multivibrator which outputs pulse signal to close the switch S and to open \bar{S} instantaneously. Two comparators detect the impulsive switching condition; if $v_1 < 0$ and $v_2 > 0$, then *M.M.* is triggered by pair of comparators. During movement of the trajectory around fixed point, the voltage v_1 is stored to C_{C1} . And If $v_1 < 0$ and $v_2 > 0$, the voltage v_1 is reset to the inverse voltage $-v_1$ instantaneously holding continuity property of $v_2(t)$, that is,

$$[v_1(t^+), v_2(t^+)]^T = [-v_1(t), v_2(t)]^T \quad \text{for } v_1(t) < 0 \text{ and } v_2(t) > 0, \quad (6)$$

where $t^+ \equiv \lim_{\epsilon \rightarrow 0} \{t + \epsilon\}$.

Because the parameter condition (5), the trajectory must reach $\{(v_1, v_2) | v_1 < 0, v_2 = 0\}$ when the switchings occur. Namely, the normalized trajectory must hit $\{(x, y) | x < 0, y = 0\}$ and jumps from $(x(T_n), 0)$ to $(-x(T_n^+), 0)$ as shown in Fig. 2, where T_n is the n -th switching moments.

Consequently, Eqn. (2) and (6) with the condition (5) are transformed into

$$\begin{cases} \dot{x} = y, \\ \dot{y} = 2\delta y - x + 1, & \text{for } S = \text{off}, \\ [x(\tau^+), y(\tau^+)]^T = [-x(\tau), 0]^T \\ & \text{for } x(\tau) < 0 \text{ and } y(\tau) = 0, \end{cases} \quad (7)$$

$(0 < \delta < 1).$

Now the system is characterized by only one parameter δ . The right figure of Fig. 2 shows a typical chaotic behaviour with $\delta \approx 0.11$.

The transconductance amplifiers are implemented by OTAs (LM13700). Realization procedure of differential voltage-controlled transconductance amplifiers by using OTAs can be found in literature [7]. The monostable multivibrator, the comparators and the analog switches are implemented by IC package of 4538, LM339 and LF398, respectively.

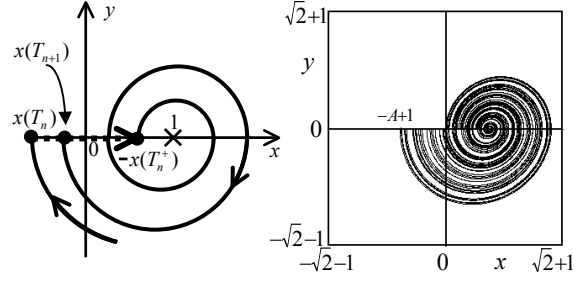

Figure 2: Behavior of Trajectories on the phase space and a typical chaos attractor. ($\delta \approx 0.11$)

2.2. Analysis

The following exact piecewise solution of Eqn. (7) for $S = \text{off}$ is derived.

$$\begin{aligned} x(\tau) &= e^{\delta\tau} \left\{ [x(0) - 1] \cos \omega\tau \right. \\ &\quad \left. + \frac{1}{\omega} [y(0) - \delta x(0) + \delta] \sin \omega\tau \right\} + 1. \end{aligned} \quad (8)$$

We focus on a trajectory starting from origin. The trajectory rotates divergently around the equilibrium point $(1, 0)$ and reaches the switching threshold after $\frac{2\pi}{\omega}$. A x -coordinate of the reaching point is obtained as $-e^{-\frac{2\pi\delta}{\omega}} + 1$ by substituting $x(0) = 0$ and $\tau = \frac{2\pi}{\omega}$ into (8). Here we define $A \equiv e^{-\frac{2\pi\delta}{\omega}} > 1$ and $l \equiv \{(x, y) | -1 < x < 0, y = 0\}$ and consider the case of $-A + 1 > -1$, that is, the minimum value of x is greater than -1 . In this case, the trajectory starting from l jumps instantaneously to the symmetric point of the origin, rotates k -times ($k = 1, 2, 3, \dots$) around the equilibrium point and it must return to l after $\frac{2k\pi}{\omega}$. We henceforth consider the parameter range

$$1 < A < 2. \quad (9)$$

If we choose l as Poincaré-section, we can define one dimensional return map f from l to itself. Letting $(x(T_n), 0)$ be the starting point, $(x(T_{n+1}), 0)$ be the return point and letting any point on l be represented by its x -coordinate, f is defined by

$$f : l \mapsto l, \quad x_{n+1} = f(x_n), \quad (10)$$

where we rewrite $x_n = x(T_n)$.

Substituting $x(0) = -x_n$ and $\tau = \frac{2k\pi}{\omega}$ into the solution (8), we obtain an explicit expression for the function f :

$$f(x_n) = \begin{cases} -A(x_n + 1) + 1 & \text{for } \frac{1}{A} - 1 < x_n \leq 0, \\ -A^2(x_n + 1) + 1 & \text{for } \frac{1}{A^2} - 1 < x_n \leq \frac{1}{A} - 1, \\ \vdots & \\ -A^k(x_n + 1) + 1 & \text{for } \frac{1}{A^k} - 1 < x_n \leq \frac{1}{A^{k-1}} - 1, \\ \vdots & \\ & (k = 1, 2, 3, \dots) \end{cases} \quad (11)$$

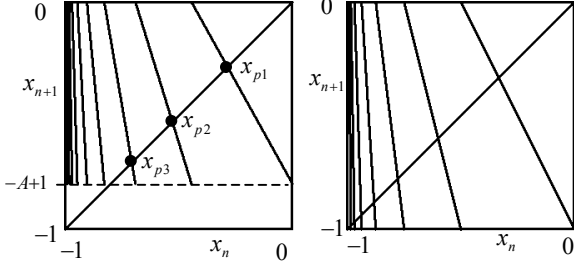

Figure 3: Chaotic return maps. (left: $A = 1.8(\delta \approx 0.09)$, right: $A \rightarrow 2(\delta \approx 0.11)$).

where each borders of piecewise map, $Th_k = \frac{1}{A^k} - 1$, are derived by solving $0 = -A^k(Th_k + 1) + 1$. Typical return map f are shown in Fig. 3. In this figure, k -th branch from the right corresponds to a trajectory with a k turn spiral.

From condition (9), since $|\frac{\partial f}{\partial x_n}| > 1$ is satisfied without discontinuous points and $f(l) \subset l$ is obvious, hence f exhibits chaos. In practice, if $1 < A < 4$ is satisfied, the system (7) behaves chaos rigorously. This paper omits the proof but it is easy in a similar way to [8].

Let x_{pk} be a k -th fixed point of (10) in descending order as shown in the left figure of Fig. 3. Note that x_{pk} corresponds to a periodic point of UPO with a k turn spiral of the continuous system (7). $x_{pk} = \frac{1-A^k}{1+A^k}$ can be obtained by solving $x_{pk} = f(x_{pk})$ if it exists. If x_{pk} exists, $x_{pk} > -A + 1$ must be satisfied as shown Fig. 3. In consequence, the existence condition of x_{pk} is

$$\frac{1 - A^k}{1 + A^k} > -A + 1. \quad (12)$$

3. A controlled CSO to stabilise unknown UPOs

3.1. Circuit and return map

We consider the circuit diagram of the proposed system which has a sample-and-hold unit as shown in Fig. 1, in the case of $K \neq 0$. A capacitor c_{C0} stores a voltage $v_{C1}(T_n)$ at the closing moment of a switch S and holds until next switching moment T_{n+1} . If \bar{S} is closed, a voltage v_{C1} is $(1-K)v_1 + Kv_{C0}$. And if $v_1 < 0$ and $v_2 > 0$, the voltage v_1 is reset to the $-v_{C1}(T_n)$ and $v_{C0}(T_n)$ is copied to the $v_{C1}(T_n)$, instantaneously. In a similar way to (7), the dynamics of this circuit is given by

$$\begin{cases} \dot{x} = y, \\ \dot{y} = 2\delta y - x + 1, & \text{for } S = \text{off}, \\ z(\tau) = z(T_n^+), & (T_n < t \leq T_{n+1}) \end{cases} \quad (13)$$

$$\begin{bmatrix} x(\tau^+) \\ y(\tau^+) \\ z(\tau^+) \end{bmatrix} = \begin{bmatrix} -(1-K)x(\tau) + Kz(\tau) \\ 0 \\ (1-K)x(\tau) + Kz(\tau) \end{bmatrix} \quad \text{for } x(\tau) < 0 \text{ and } y(\tau) = 0, \quad (0 < \delta < 1)$$

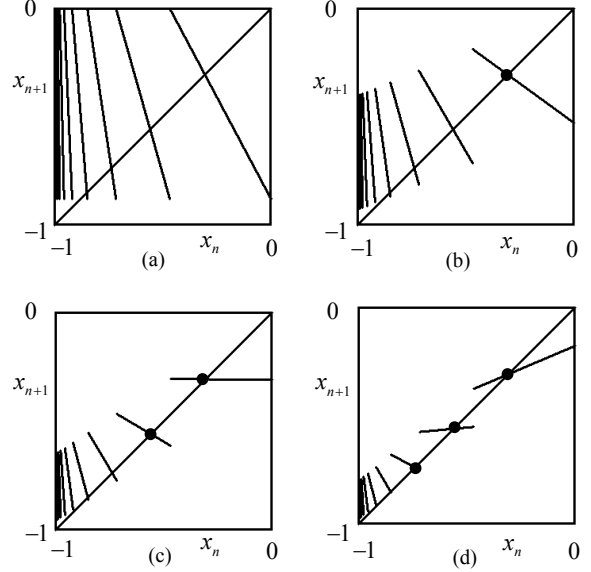

Figure 4: Typical shapes of the return map (15). ($A=1.88$, (a) $K = 0$, (b) $K = 0.4$, (c) $K = 0.65$, (d) $K = 0.8$, the black circle represents stable fixed points.)

where $z = \frac{g_2}{T} v_{C0}$.

Let us consider the behavior of the solution on phase space. Note that $z(T_{n+1}) = z(T_n^+)$ because of the third row of (13). At a switching moment T_{n-1} , the state (x, y) jumps to $(-z(T_n), 0)$ and the trajectory goes from $(-z(T_n), 0)$. The trajectory rotates k times around the equilibrium point and must return to switching threshold. In the meantime, $z(\tau)$ holds $z(T_n)$. At the next switching moment T_n , $z(T_{n+1})$ is given by

$$z(T_{n+1}) = z(T_n^+) = (1 - K) \cdot x(T_{n+1}) + K \cdot z(T_n). \quad (14)$$

By using the map f , $x(T_{n+1})$ is represented as $x(T_{n+1}) = f(z(T_n))$. Therefore the following 1-dimensional discrete time system for state z is obtained.

$$z_{n+1} = (1 - K) \cdot f(z_n) + K \cdot z_n \quad (15)$$

where we rewrite $z_n = z(T_n)$. Now the system dynamics of (13) is governed by 1-D return map (15) with two parameters A and K . The internal state x_n is given by $f(z_{n-1})$.

Substituting $z_n = x_{pk}$ into (15), we obtain $z_{n+1} = x_{pk}$ because of $x_{pk} = f(x_{pk})$. Therefore, it is clear that the return map (15) has fixed points x_{pk} in the same as (10). That is, if the parameter K is set to be stable around x_{pk} , then the unstable fixed point x_{pk} of (10) can be stabilized without the location information. Typical shapes of the return map (15) are shown in Fig. 4. The map as shown in Fig. 4(a) is corresponding to the original map (10). The map in Fig. 4(b), (c) and (d) has 1, 2 and 3 stable fixed point(s), respectively.

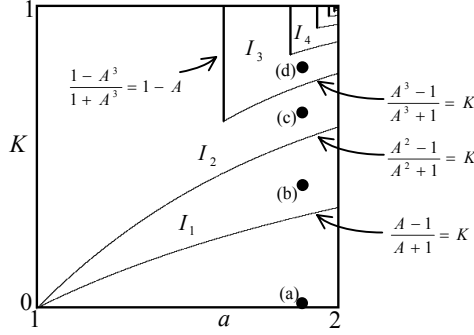

Figure 5: A parameter space.

3.2. Analysis

We consider the stability of the system (15) around the fixed point x_{pk} . It is given by

$$\left| \frac{\partial z_{n+1}}{\partial z_n} \Big|_{z_n=x_{pk}} \right| < 1. \quad (16)$$

Hence the control gain K to generate a stabilized fixed point is determined by solving the following inequality:

$$\left| (1-K) \frac{\partial f(z_n)}{\partial z_n} \Big|_{z_n=x_{pk}} + K \right| < 1. \quad (17)$$

From (10) and (17), we can derive the condition of K to stabilize x_{pf} as follows.

$$\frac{A^k - 1}{A^k + 1} < K < 1. \quad (18)$$

In conformity with (12) and (18), we obtain the parameter region of (A, K) for existing the stable fixed point x_{pk} . It is represented as

$$D_k = \left\{ (A, K) \left| \begin{array}{l} \frac{A^k - 1}{A^k + 1} < K < 1, \\ \frac{1 - A^k}{1 + A^k} > -A + 1, \quad 1 < A < 2 \end{array} \right. \right\}. \quad (19)$$

From (19), it is noticed that D_{k+1} is subset of D_k . It means that the fixed point x_{pk} must be stable in the parameter region D_{k+1} such as x_{pk+1} is stable. We define a parameter region I_k as

$$I_k = D_k - D_{k+1}. \quad (20)$$

I_k is the region such that fixed points $(x_{p1}, x_{p2}, \dots, x_{pk})$ are stable. Figure 5 shows the parameter space of (A, K) which depicts the existence region I_k .

4. Conclusions

We proposed a novel nonlinear system which consists of a chaotic system and a dynamic controller with instantaneous state setting method. The proposed control system

effectively performs to stabilize Unstable Periodic Orbits embedded on chaos attractor of the chaotic system. The condition to stabilize Unstable Periodic Orbits was provided. And we verified some theoretical results in simulations.

References

- [1] E.Ott, C.Grebogi and J.A.Yorke, "Controlling Chaos," Phys. Rev. Lett., vol. 64, no. 11, pp.1196-1199, 1990.
- [2] K. Pyragas, "Continuous control of chaos by self-controlling feedback," Physics letters, A170, 1992.
- [3] M. A. Hassouneh, H.-C. Lee and E. H. Abed, "Washout Filters in Feedback Control: Benefits, Limitations and Extensions," Proc. of the 2004 American Control Conference, pp. 3950-3955, (2004).
- [4] PINGEL Detlef, SCHMELCHER Peter, DIAKONOS Fotis K. , "Stability transformation: a tool to solve nonlinear problems," Physics reports, vol. 400, no. 2, pp. 67-148 (2004).
- [5] H. Nakano and T. Saito, "Grouping synchronization in a pulse-coupled network of chaotic spiking oscillators," IEEE Trans. Neural Networks, 15, 5, pp. 1018-1026 (2004).
- [6] K.Mitsubori and T.Saito, "Dependent switched capacitor chaos generator and its synchronization," IEEE Trans. Circuit Syst. I, 44, 12, pp.1122-1128 (1997).
- [7] Y. Takahashi, H. Nakano and T.Saito, "A simple hyperchaos generator based on impulsive switching," IEEE Trans. CAS-II, vol. 51, no. 9, pp. 468-472, (1998).
- [8] T. Tsubone and T. Saito, "Stabilizing and Destabilizing Control for a Piecewise-Linear Circuit," IEEE Trans. CAS-I, vol. 45, no. 2, pp. 172-177, (1998).