

Time-delayed feedback control with an unstable control loop realizing wide range operation

Hiroyuki Shirahama[†], Klaus Höhne[‡], Hartmut Benner[‡] and Wolfram Just^{‡†}

[†]Faculty of Education, Ehime University

Bunyoucho 3, Matsuyama, 790-8577 Japan

[‡]Institute of Solid State Physics, TU Darmstadt

Hochschulstr. 6, D-63289 Darmstadt, Germany

^{‡†}School of Math. Science, Queen Mary / University of London

Mile End Road E1 4NS, London, United Kingdom

Email: shirahama@ed.ehime-u.ac.jp

Abstract—We demonstrate by electronic circuit experiments the feasibility of an unstable control loop to stabilize torsion-free orbits by time-delayed feedback control. Our experiments show the importance of the coupling scheme for global control performance.

1. Introduction

The idea to control chaos, e.g. to stabilize unstable periodic orbits (UPOs) embedded in the chaotic attractor by applying small perturbations, has already been realized in the early 1990s. The pioneering method of Ott, Grebogi, and Yorke [1], from the very beginning, was well understood from the theoretical point of view, but difficult to apply to fast experimental systems. The time-delayed feedback method (TDFC) of Pyragas [2] turned out to be easy to apply in experiment, but difficult to handle theoretically, since any low-dimensional system of differential equations acquires infinite dimensionality due to the action of delay terms.

Time-delayed feedback methods are based on measuring a time signal $s(t)$. The control force is generated by a time-delayed difference signal:

$$F(t) = k(s(t) - s(t - \tau)) \quad (1)$$

For proper choice of the control amplitude k stable periodic oscillations can be achieved. Such a scheme is non-invasive if the delay time τ is chosen to coincide with the period of the target state. Once the system trajectory has settled on the UPO the control force $F(t)$ vanishes by construction.

A large number of successful applications of TDFC have been reported in various fields of physics, engineering, chemistry and biology [3]. While TDFC is a convenient technique for controlling chaos, a serious drawback called the 'odd number limitation' became evident [4] predicting that in driven systems UPOs with an odd number of real unstable Floquet multipliers can never be stabilized by conventional TDFC. In other words only UPOs with finite torsion can be stabilized [5].

To overcome this limitation Pyragas introduced the counterintuitive idea of introducing an unstable time-delayed feedback controller (UTDFC) [6]. Such a controller has an additional unstable loop variable which artificially increases the number of the real Floquet multipliers to become even and, thus, avoids the odd number limitation.

2. Unstable van der Pol oscillator

A prominent paradigm showing such torsion-free unstable orbits is the unstable van der Pol oscillator which is described by the following equations of motion:

$$\dot{x}(t) = -y(t) + \varepsilon x(t) + x^3(t)/3, \quad (2a)$$

$$\dot{y}(t) = x(t). \quad (2b)$$

Here, ε is the bifurcation parameter of system, and the time scale is normalized to the inverse oscillator frequency. Equation (2) differs from that for the conventional van der Pol oscillator merely by the sign of the nonlinear coefficient. For $\varepsilon < 0$, this equation has two coexisting solutions, a stable fixed point at the origin $x = y = 0$, and an unstable limit cycle with period $\tau = 2\pi + \mathcal{O}(\varepsilon)$, amplitude $2\sqrt{-\varepsilon} + \mathcal{O}(\varepsilon)$, and a real positive Floquet exponent $\lambda = -\varepsilon + \mathcal{O}(\varepsilon^{3/2})$. The real positive Floquet exponent indicates that the limit cycle is unstable and shows no torsion.

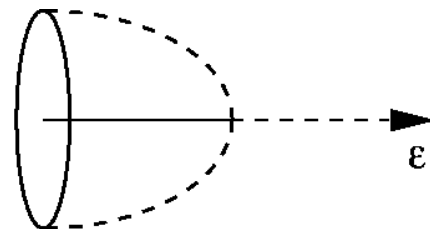

Figure 1: Bifurcation diagram of the unstable van der Pol oscillator. For $\varepsilon < 0$ the stable fixed point at the origin coexists with an UPO of amplitude $2\sqrt{-\varepsilon}$. For $\varepsilon > 0$ there is only an unstable fixed point at the origin.

3. Applying the concept of an unstable controller

We assume that x is a system variable accessible in experiment. To stabilize the unstable periodic orbit appearing for $\varepsilon < 0$ we consider the following control algorithm:

$$\dot{x}(t) = -y(t) + \varepsilon x(t) + x^3(t)/3 + w(t)f(x(t)) \quad (3a)$$

$$\dot{y}(t) = x(t) \quad (3b)$$

$$\dot{w}(t) = \lambda_c w(t) - k(x(t) - x(t - \tau))f(x(t)) \quad (3c)$$

The term $wf(x)$ in Eq. (3a) is the control signal perturbing the x -variable. The specific form of this coupling is given by the function $f(x)$ and will be specified later. Equation (3c) describes an unstable delayed feedback controller with $\lambda_c > 0$. Here $w(t)$ is the dynamical variable of the controller and k determines the feedback strength. Note that the control scheme does not change the solution of the free system corresponding to the unstable orbit of period τ , since for $x(t) = x(t - \tau)$ Eq. (3c) is satisfied by $w = 0$ and the control signal $w(t)f(x(t))$ in Eq. (3a) vanishes.

We just mention that in a recent paper [7] Eq. (3) has been considered as a paradigm of a subcritical Hopf bifurcation showing an unstable torsion-free limit cycle. The possibility to stabilize such an orbit was explored, both analytically and numerically, for the specific choice of a linear coupling function, $f(x) = x$, and successful control was achieved.

4. Design of the experiment

In order to probe the concept of an unstable controller in experiment we designed an autonomous electronic circuit which is related to Eq. (3).

Fig. 2 shows the equivalent circuit scheme of the unstable van der Pol oscillator system with an unstable controller based on active elements. The upper part corresponds to the unstable van der Pol oscillator. The linear terms were implemented by operational amplifiers TL084 and the nonlinearities by AD633 multiplier ICs. The fundamental period T of the unstable van der Pol oscillator was set to 0.628 ms by trimming the time constants of the integrators, so that the resulting dynamics was easy to handle with our equipment. The lower part of Fig. 2 marked by the dashed frame shows the unstable control loop. It was designed from the same type of active components. The control amplitude k and the positive exponent λ_c as well as the bifurcation parameter ε of the unstable van der Pol oscillator were simply determined by the gain of the electronic amplifiers which were tuned by resistors.

For the time-delayed signal, we designed a digital delay system based on a combination of an analog-to-digital converter (ADC) of 8-bits resolution, a shift register ("FIFO") and a digital-to-analog converter (DAC). The accuracy of the delay time could be set to better than 1% of T by using a clock frequency of a few hundred kHz. The output signal of the delay system is smoothed by a low-pass filter with a bandwidth of about 10% of the clock frequency.

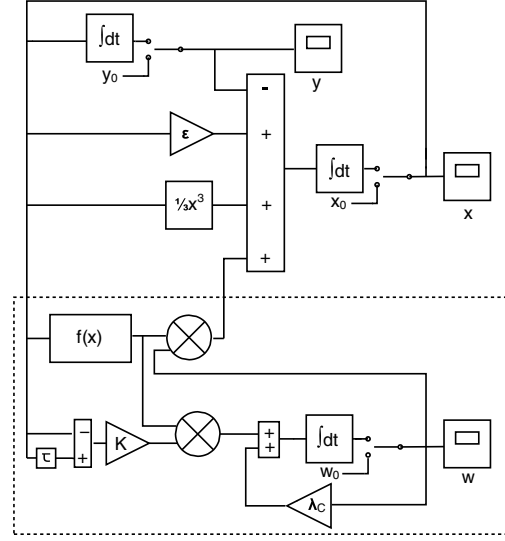

Figure 2: Block diagram of the van der Pol oscillator with unstable control loop (setup built from active components).

In our experiment the coupling function $f(x)$ of the control algorithm Eq. (3) was chosen to be either a linear function of $x(t)$ or of sigmoidal type $f(x) = \text{sign}(x)$. In the linear case the coupling function was just given by the voltage representing the x -component. In the sigmoidal case the coupling function was experimentally realized by means of a comparator.

To ensure accurate initial conditions we used electronic switches parallel to each of the integrator outputs which generate the variables $x(t)$, $y(t)$ and $w(t)$. These switches allowed to apply adjustable constant voltages x_0 , y_0 and w_0 , respectively, and a precise timing. Thus, when switching on the system at $t = 0$, the variables $x(t)$ and $y(t)$ started from a well-defined state. At about one cycle later the feedback loop generating the control signal was switched on, simultaneously with the controller variable $w(t)$. Such a time-lag was necessary to obtain an appropriate delayed signal reflecting the dynamics of the uncontrolled system close to the initial state. Note that the control generally failed when the feedback is switched on earlier than one cycle or later than three or four cycles. This is understandable since in the former case a proper delay signal has not yet developed while in the latter case the unstable system has already escaped too far away from the target state. The data were recorded by a digital oscilloscope with a sampling rate higher than 100MHz and with file length larger than 216 words.

This setup allowed to study in detail the basin of attraction of the controlled state. In the following subsection we describe control experiments for both linear and sigmoidal coupling.

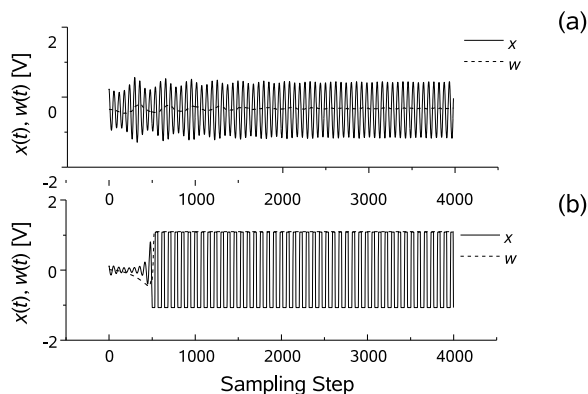

Figure 3: *Linear coupling*: Time series of the system variable $x(t)$ (line) and the control loop variable $w(t)$ (dashed) for fixed parameters $\varepsilon = -0.1$, $k = 0.3$ and $\lambda_c = 0.051$, but different initial conditions. (a) Initial conditions close to the UPO $(x_0, y_0, w_0) = (0.6, 0, 0)$: control successful. (b) Initial conditions close to the origin $(x_0, y_0, w_0) = (0.1, 0, 0)$: control fails.

5. Experimental results

5.1. Linear coupling

As pointed out in [7] for the most trivial choice of the coupling function, $f(x(t)) = \text{const}$ the system variable $x(t)$ and the unstable control loop variable $w(t)$ immediately decouple and the control fails. The next simplest coupling is of linear type. It was shown by both analytical and numerical investigations that such an unstable time-delayed feedback controller can stabilize the torsion-free UPO of the unstable van der Pol oscillator.

The first step was to confirm this result in experiment. We adjusted the parameters to $\varepsilon = -0.1$, $k = 0.3$, and $\lambda_c = 0.051$. Fig. 3(a) shows a time series of $x(t)$ and $w(t)$ for the initial conditions $(x_0, y_0, w_0) = (0.6, 0, 0)$, which is pretty close to the UPO. The feedback loop was switched on one period later in order to generate a proper delay signal $x(t - \tau)$. This switching defines time zero in Fig. 3. After a transient process of about 2500 time-steps a stable oscillation in x appears and the control variable $w(t)$ converges to zero. The UPO is stabilized, and the control force does not affect anymore the stabilized van der Pol oscillator. The situation changes dramatically for initial conditions far away from the UPO. In Fig. 3(b) we have chosen the initial conditions $(x_0, y_0, w_0) = (0.1, 0, 0)$. The $x(t)$ -component immediately starts oscillating between the saturation limits of the active elements, and the control variable $w(t)$ diverges. This examples already indicates the importance of global properties in practical applications.

We probed systematically the dependence of control performance on the chosen initial conditions. We fixed w_0 at zero and varied both x_0 and y_0 from -1.0 V to 1.0 V in steps of 10 mV. The result is shown in Fig. 4. The black areas denote the basin of attraction for the stabilized periodic state.

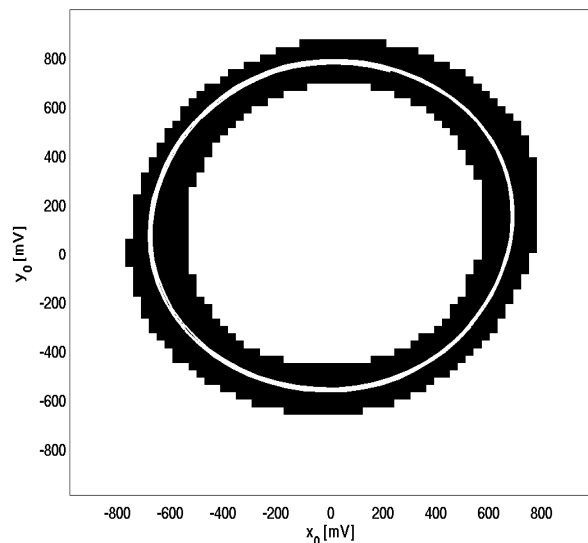

Figure 4: Experimental basins of attraction for linear coupling in black. Periodic orbit in white.

It consists of a narrow annulus surrounding the UPO which is indicated by the white line. For initial conditions outside the basin of attraction the time series shows a behavior as given in Fig. 3(b). Small basins of attraction make the UTDFC method unsuitable for practical applications.

5.2. Phase coupling

In order to extend the basins of attraction a different type of coupling was applied. A possible reason for failing control might have been the overshooting of the feedback signal when the control is switched on and high-amplitude transients occur. To suppress such undesired feedback oscillations the control signal has to be limited to a certain level. Obviously a sigmoidal control function could do this job much better. So we replaced the linear control function by a hyperbolic tangent, $f(x) = \tanh(\beta x)$ with $\beta \gg 1$, which was easily implemented in our electronic circuits by means of an operational amplifier acting as a comparator. Now the coupling function $f(x)$ just probes the sign of $x(t)$, which means that the coupling in eq.(3) appears through the phase of the variable only, without any dependence on the amplitude.

We carry out the same experiment as in the case of linear coupling. The parameters were fixed to $\varepsilon = -0.1$, $k = 0.10$, and $\lambda_c = 0.051$. In Fig. 5 we have shown the time series for $x(t)$ and $w(t)$ for the same initial conditions as in Fig. 3, i.e. (a) close to the orbit $(x_0, y_0, w_0) = (0.6, 0, 0)$ and (b) far from the UPO $(x_0, y_0, w_0) = (0.1, 0, 0)$. The obvious difference to Fig. 3 is that for both conditions the UPO is stabilized and the controller variable vanishes. Comparing the time series of Fig. 5 it is evident that the transient time is much longer for initial condition far away from the UPO

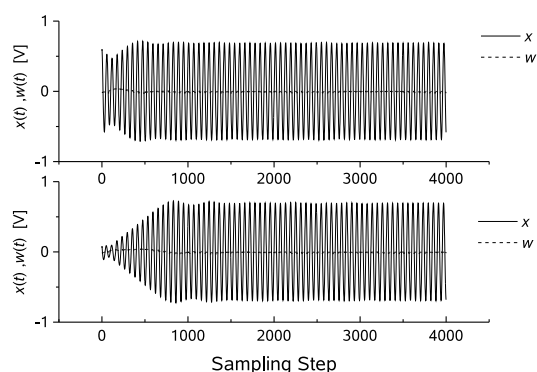

Figure 5: *Phase coupling*: Timeseries of the observed variable $x(t)$ (line) and the control loop variable $w(t)$ (dashed) for fixed parameters but different initial conditions. The parameters are $\varepsilon = -0.1$, $k = 0.10$ and $\lambda_c = 0.051$. (a) Initial conditions close to UPO $(x_0, y_0, w_0) = (0.6, 0, 0)$. (b) Initial conditions close to origin $(x_0, y_0, w_0) = (0.1, 0, 0)$

(b) than for initial conditions close to the UPO (a).

We found that phase coupling results in a dramatic increase of the basin of attraction, c.f. Fig. 6. Now, even close to the limiting bifurcation, the basin of attraction includes the whole area inside the UPO (except for the very centre).

6. Conclusions

We have shown for the first time by experimental means that the concept of an unstable time-delayed feedback controller is able to overcome the odd number limitation. When applying a linear coupling $f(x) = x$ successful control was obtained only for a small range of initial conditions close to the target orbit. This experimental results are in good agreement with numerical results.

For many technical application it is difficult or even impossible to set initial conditions precisely. So the size of the basin of attraction of the target orbit is of similar importance as stability considerations. The phase coupling, which can technically be implemented in a rather simple way, is able to change the size of the basin of attraction dramatically. Apart from the origin the basin of attraction now covers the full area inside the orbit. With this type of coupling the unstable time-delayed feedback controller becomes suitable for various practical applications.

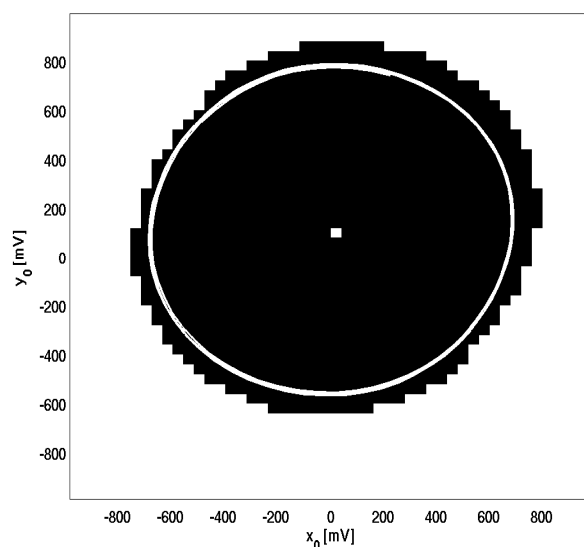

Figure 6: Experimental basins of attraction for phase coupling in black. Periodic orbit in white.

References

- [1] E. Ott, C. Grebogi, J. A. Yorke, “Controlling Chaos,” *Phys. Rev. Lett.*, vol. 64, pp. 1196, 1990
- [2] K. Pyragas, “Continuous control of chaos by self-controlling feedback,” *Phys. Lett. A*, vol. 170, pp. 421–428, 1992
- [3] H. G. Schuster (Ed.), “Handbook of Chaos Control” Wiley-VCH, Berlin, 1997
- [4] H. Nakajima, “On analytical properties of delayed feedback control of chaos,” *Phys. Lett. A*, vol. 232, pp. 207–210, 1997
- [5] W. Just et al., “Mechanism of Time-Delayed Feedback Control,” *Phys. Rev. Lett.*, vol. 78, pp. 203–206, 1997
- [6] K. Pyragas, “Control of Chaos via an Unstable Delayed Feedback Controller,” *Phys. Rev. Lett.*, vol. 86, pp. 2265–2268, 2001
- [7] K. Pyragas, V. Pyragas, H. Benner, “Delayed feedback control of dynamical systems at a subcritical Hopf bifurcation,” *Phys. Rev. E*, vol. 70, 056222, 2004
- [8] K. Höhne et al., “Global Properties in an Experimental Realization of Time-Delayed Feedback Control with an Unstable Control Loop,” *Phys. Rev. Lett.*, vol. 98, 214102, 2007