

Synchronization Phenomena in Coupled Parametrically Excited van der Pol Oscillators

Hironori Kumeno[†] and Yoshifumi Nishio[†]

[†]Dept. of Electrical and Electronic Eng.,
 Tokushima University, Tokushima 770-8506, JAPAN
 Email: kumeno@ee.tokushima-u.ac.jp, nishio@ee.tokushima-u.ac.jp

Abstract—In this study, we investigate synchronization of parametrically excited van der Pol oscillators. In the case of two subcircuits, we confirm that the two subcircuits are synchronized at the opposite-phase without phase difference in the functions corresponding to the parametric excitation. In the case of three subcircuits, we confirm self-switching phenomenon of synchronization states.

1. Introduction

Synchronization is one of the fundamental phenomena in nature and it is observed over the various fields. Studies on synchronization phenomena of coupled oscillators are extensively carried out in various fields, physics [1], biology [2], engineering and so on. We consider that it is important to investigate the synchronization phenomena of coupled oscillators for the future engineering application. The coupled van der Pol oscillator is one of coupled oscillators, and synchronization generated in the system can model certain synchronization of natural rhythm phenomena. The van der Pol oscillator is studied well because it is expressed in simple circuit. Parametric excitation circuit is one of resonant circuits, and it is important to investigate various nonlinear phenomena of the parametric excitation circuits for future engineering applications. In simple oscillator including parametric excitation, Ref. [3] reports that the almost periodic oscillation occurs if nonlinear inductor has saturation characteristic. Additionally the occurrence of chaos is referenced in Ref. [4] and [5].

In this study, we investigate synchronization of parametrically excited van der Pol oscillators. By carrying out computer calculations for two or three subcircuits case, we confirm that various kinds of synchronization phenomena of chaos are observed. In the case of two subcircuits, the opposite-phase synchronization is observed. In the case of three subcircuits, self-switching phenomenon of synchronization states is observed.

2. Circuit model

The circuit model used in this study is shown in Fig 1. In our system n same parametrically excited van der Pol oscillators are coupled by one resistor R . The circuit includes a time-varying inductor L whose characteristics are

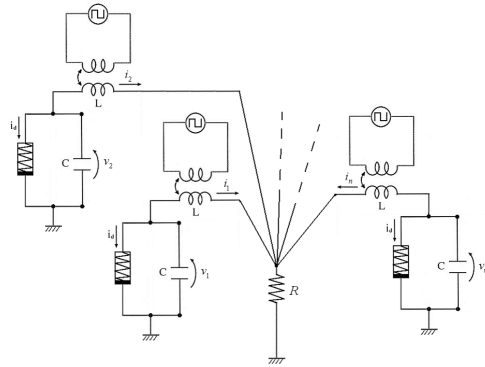

(a) Parametrically excited van der Pol oscillators coupled by a resistor.

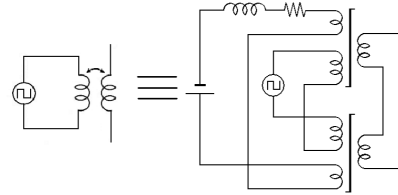

(b) Time-varying inductor.

Figure 1: Circuit model.

given as the following equation. The time-varying inductor is shown as Fig. 1(b).

$$L = L_0\gamma(t). \quad (1)$$

$\gamma(\tau)$ is expressed in a rectangular wave as shown in Fig. 2, and its amplitude and angular frequency are termed α and ω , respectively. The $v - i$ characteristics of the nonlinear resistor are approximated by the following equation.

$$i_d = -g_1v_k + g_3v_k. \quad (2)$$

By changing the variables and the parameters,

$$\begin{aligned} t &= \sqrt{L_0C}\tau, \quad v_k = \sqrt{\frac{g_1}{g_3}}x_k, \quad \delta = \sqrt{\frac{C}{L_0}}R, \\ i_k &= \sqrt{\frac{g_1}{g_3}}\sqrt{\frac{C}{L_0}}y_k, \quad \varepsilon = g_1\sqrt{\frac{L_0}{C}}, \end{aligned} \quad (3)$$

the normalized circuit equations are given by the following equations.

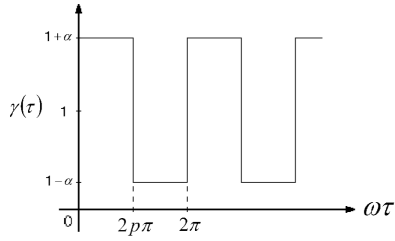

Figure 2: Function relating to parametrically excitation.

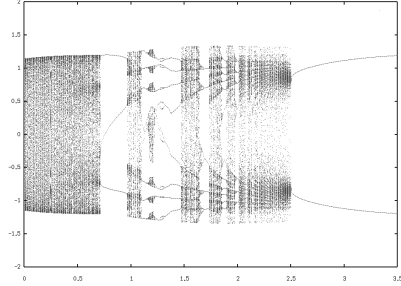

Figure 3: One-parameter bifurcation diagram of isolated subcircuit. Horizontal axis: x . Vertical axis: ε . $\alpha = 0.95$ and $\omega = 1.50$.

$$\begin{cases} \frac{dx_k}{d\tau} = \varepsilon(x_k - x_k^3) - y_k \\ \frac{dy_k}{d\tau} = \frac{1}{\gamma(\tau)}x_k - \delta \sum_{j=1}^n y_j. \end{cases} \quad (4)$$

Figure 3 shows the bifurcation diagram observed from the isolated subcircuit. When parameter ε changes, periodic attractors, quasi-periodic attractors and chaotic attractors are confirmed from the isolated subcircuit. Figure 4 shows examples of chaotic attractors and Poincaré maps observed from the isolated subcircuit. We define the Poincaré section as $\omega\tau = 2n\pi$.

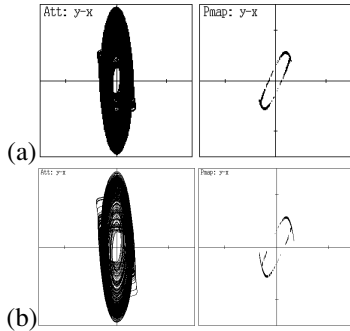

Figure 4: Examples of chaotic attractors and Poincaré maps observed from subcircuit. $\alpha = 0.95$ and $\omega = 1.50$. (a) $\varepsilon = 1.0$. (b) $\varepsilon = 1.5$.

3. Two subcircuits case

In this section, we consider the case of $n = 2$. Only two parametrically excited van der Pol oscillators are coupled by one resistor. First, fix $\varepsilon = 1.50$, $\alpha = 0.95$, $\omega = 1.50$ and $\delta = 0.80$ and vary phase difference of the rectangular wave. Two subcircuits generate chaos for these parameter values.

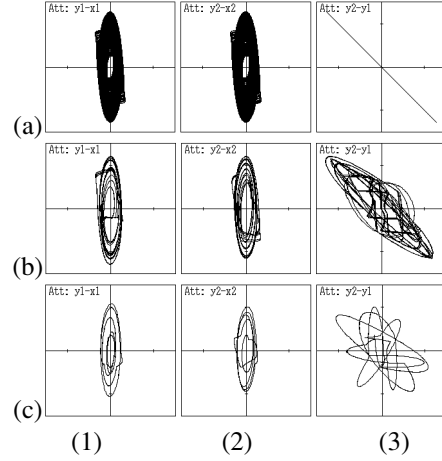

Figure 5: Attractors and phase differences. $\varepsilon = 1.50$, $\alpha = 0.95$, $\omega = 1.50$ and $\delta = 0.80$. Phase difference of rectangular wave: (a) 0, (b) $\pi/20$ and (c) $\pi/4$. (1) x_1 versus y_1 . (2) x_2 versus y_2 . (3) y_1 versus y_2 .

Figure 5 shows computer calculated results. As shown in Fig. 5(a), when there is not phase difference, two subcircuits are synchronized at the opposite-phase completely. However, as phase difference increases, two circuits become out of synchronization (see Figs. 5(b) and (c)).

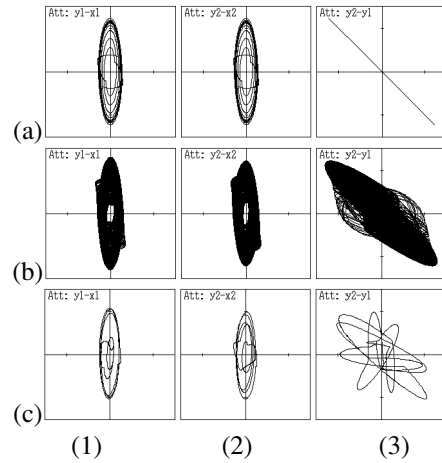

Figure 6: Attractors and phase differences. $\varepsilon = 1.35$, $\alpha = 0.95$, $\omega = 1.50$ and $\delta = 0.80$. Phase difference of rectangular wave: (a) 0, (b) $\pi/20$ and (c) $\pi/4$. (1) x_1 versus y_1 . (2) x_2 versus y_2 . (3) y_1 versus y_2 .

Second, fix $\varepsilon = 1.35$, $\alpha = 0.95$, $\omega = 1.50$ and $\delta = 0.80$ and vary phase difference of the rectangular wave. Two subcircuits generate periodic attractor for these parameter values. Figure 6 shows computer calculated results. In the same way, when there is not phase difference, two subcircuits are synchronized at the opposite-phase completely as shown in Fig. 6(a). And as phase difference increases, two circuits become out of synchronization (see Figs. 6(b), (c) and (d)). Additionally, chaotic attractor is obtained as shown in Fig. 6(b).

4. Three subcircuits case

In this section, we consider the case of $n = 3$. Figure 7 shows computer calculated results for $\varepsilon = 1.50$, $\alpha = 0.95$, $\omega = 1.50$, $\delta = 0.80$ and there is not phase difference of the rectangular wave.

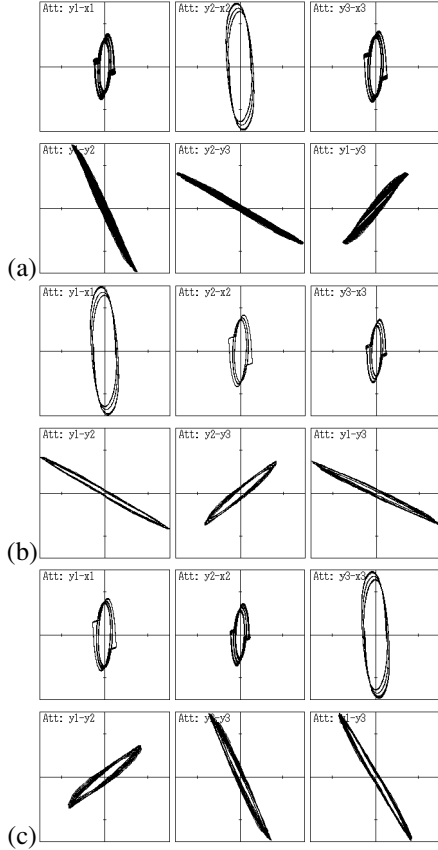

Figure 7: Attractors and phase differences. $\varepsilon = 1.50$, $\alpha = 0.95$, $\omega = 1.50$ and $\delta = 0.80$.

In this case, self-switching phenomenon of synchronizations is observed. In Fig. 7, the upper line shows attractors of the subcircuits and the lower line shows phase differences between subcircuits. And the states of synchronization (a), (b) and (c) switch with time. Figure 8 shows time series of self-switching phenomenon of synchronizations. As shown in Fig. 7(a) and Fig. 8(a), subcircuit 2 synchronizes with other two subcircuits at opposite-phase. However, as time advances, the amplitude of either subcircuit 1 or subcircuit 3 becomes small (it is subcircuit 3 in Fig. 8(2)), and the pattern of synchronization finally changes to another pattern. After the switching, the other subcircuit which synchronized to subcircuit 2 at opposite-phase becomes to synchronizes with the other two subcircuits at opposite-phase as shown in the Fig 7(b) and Fig. 8(b). Furthermore, as time passes next switchings occur in a chaotic way.

Switching speed is related to the coupling parameter δ . Figure 9 shows the mean value and the standard deviation of the sojourn time of self-switching. Figure 10

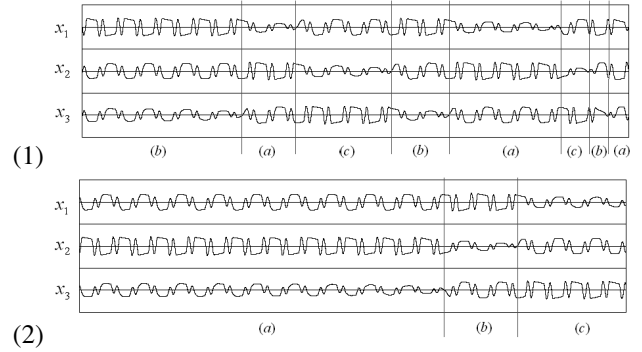

Figure 8: time series of self-switching. $\varepsilon = 1.50$, $\alpha = 0.95$ and $\omega = 1.50$. (1) $\delta = 0.80$. (2) $\delta = 20.00$.

shows time series of amplitude difference between subcircuits. In Fig. 10, large amplitude shows opposite-phase synchronization. If the coupling parameter δ is small (see Fig. 10(a)), switching speed is fast. As the coupling parameter δ increases, switching speed becomes slow (see Fig. 10(b)). Additionally, self-switching phenomenon of synchronizations is also confirmed when the isolated subcircuits generate periodic attractors for $\varepsilon = 1.35$. However, when the parameter ε is small as $\varepsilon = 1.00$, self-switching phenomenon of synchronizations is not observed. And a pair of subcircuits which depend on initial values are synchronized at opposite-phase. Thus, generation of the self-switching phenomenon of synchronizations is related to the parameter ε , and its switching speed is related to the coupling parameter δ .

From the preceding section, two subcircuits are synchronized at opposite-phase for no phase difference of the rectangular wave. Thus, the effect of parametric excitation is strong, and opposite-phase synchronization is stable for no phase difference of the rectangular wave. However in case of three subcircuits, there is no stable pair of subcircuits because the number of circuit is odd. So self-switching phenomena of synchronization occurs. From these, we consider that interesting self-switching phenomena of synchronization occur when the number of subcircuit is odd (for example the number of subcircuits is 5 or 7).

Second, we consider the case that there is phase difference of the rectangular wave. Fix $\varepsilon = 1.50$, $\alpha = 0.95$, $\omega = 1.50$ and $\delta = 0.30$, and phase shifts of the rectangular wave of the subcircuits to $2\pi/3$ and $4\pi/3$. In this case, self-switching phenomenon of synchronizations is not observed. Figure 11 shows one of three different types of synchronization states. These three synchronization states can be obtained by giving different pattern of phase shift of the rectangular wave. Two of the three subcircuits are synchronized at the opposite-phase. A pair of synchronized subcircuits is decided by the sequence of phase shift of the rectangular wave.

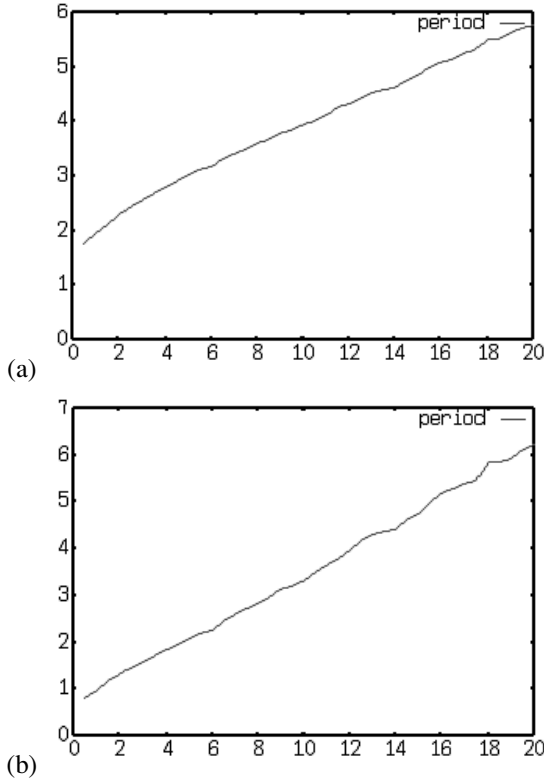

Figure 9: Sojourn time of self-switching. Horizontal axis: δ . Vertical axis: period. $\varepsilon = 1.50$, $\alpha = 0.95$ and $\omega = 1.50$. (a) Mean value. (b) Standard deviation.

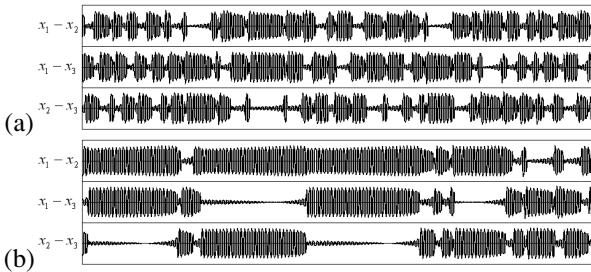

Figure 10: Time series. $\varepsilon = 1.50$, $\alpha = 0.95$ and $\omega = 1.50$. (a) $\delta = 0.80$. (b) $\delta = 20.0$.

5. Conclusions

In this study, we investigated synchronization of parametrically excited van der Pol oscillators. By carrying out computer calculations for two or three subcircuits case, we confirmed that various kinds of synchronization phenomena of chaos were observed. In the case of two subcircuits, we confirmed that synchronization phenomena are related to phase difference of the functions that corresponding to the parametric excitation. Then the two subcircuits are synchronized at the opposite-phase. In the case of three subcircuits, three coupling van der Pol oscillators which do not include parametric excitation are synchronized at the three-phase. However, three coupling parametric excited van der Pol oscillators generate self-switching phenomenon of synchronization states when there is not phase difference of the

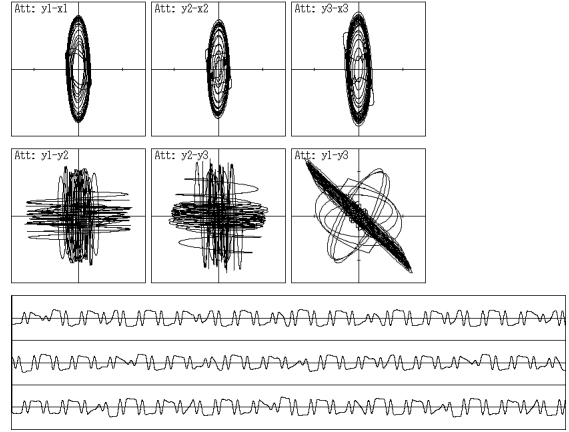

Figure 11: Attractors, phase differences and time series. $\varepsilon = 1.50$, $\alpha = 0.95$, $\omega = 1.50$ and $\delta = 0.30$. Phase differences of rectangular wave are $2\pi/3$ and $4\pi/3$.

functions corresponding to the parametric excitation. On the other hand, when there is phase difference, two of the three subcircuits are synchronized at the opposite-phase.

Acknowledgments

This work was partly supported by Yazaki Memorial Foundation for Science and Technology.

References

- [1] I. Belykh, M. Hasler, M. Lauret and H. Nijmeijer, "Synchronization and graph topology," *Int. J. Bifurcation and Chaos*, vol.15, no.11, pp.3423-3433, Nov. 2005.
- [2] J. Cosp, J. Madrenas, E. Alarcon, E. Vidal and G. Villar, "Synchronization of nonlinear electronic oscillators for neural computation," *IEEE Trans. Neural Networks*, vol.15, no.5, pp.1315-1327, Sep. 2004.
- [3] C. Hayashi, "Nonlinear Oscillations in Physical Systems," Chap. 11, McGraw-Hill, New York (1964).
- [4] C. Hayashi, M. Abe, K. Oshima and H. Kawakami, "The method of mapping as applied to the solution for certain types of nonlinear differential equations," *Ninth International Conference on Nonlinear Oscillations*, Kiev (Aug.-Sept.1981).
- [5] M. Inoue, "A Method of Analysis for the Bifurcation of the Almost Periodic Oscillation and the Generation of Chaos in a Parametric Excitation Circuit," *Trans. of IEICE*, vol. J68-A, no. 7, pp. 621-626, 1985.