



Controlling Unknown Saddle Type Steady States of Dynamical Systems with Latency in the Feedback Loop

A.Tamaševičius¹, S.Bumelienė¹, E.Tamaševičiūtė², G.Mykolaitis³, R.Kirvaitis³, E.Lindberg⁴

¹Semiconductor Physics Institute, A. Goštauto 11, Vilnius, LT-01108, Lithuania

²École Polytechnique Fédérale de Lausanne, 1015 Lausanne, Switzerland

³Vilnius Gediminas Technical University, Saulėtekio al. 11, Vilnius, LT-10223, Lithuania

⁴DTU Elektro Department, 348, Technical University of Denmark, DK-2800 Lyngby, Denmark
Email: tamasev@pfi.lt, el@elektro.dtu.dk

Abstract—We suggest an adaptive control technique for stabilizing saddle type unstable steady states of dynamical systems. The controller is composed of an unstable and a stable high-pass filters operating in parallel. The mathematical model is considered analytically and numerically. The conjoint controller is sufficiently robust to time latencies in the feedback loop. In addition, it is not sensitive to the damping parameters of the system and is relatively fast. Experiments have been performed using a simplified version of the electronic Young-Silva circuit imitating behavior of the Duffing-Holmes double-well oscillator.

1. Introduction

The problem of stabilizing unstable steady states (USS) is of great importance in nonlinear dynamics, especially in its engineering applications. Classical control methods require as a reference point the coordinates of the USS. In many practical cases the location of the USS is either unknown or it may slowly vary with time. Therefore adaptive, reference-free methods, automatically locating the USS are preferable.

The simplest adaptive technique for stabilizing USS is based on derivative controller. A perturbation in the form of a derivative dx/dt derived from an observable $x(t)$ does not change the original system, since it vanishes when the variable approaches the steady state. This technique works well for oscillating systems and has been applied to stabilize a laser [1], an electrical circuit [2] and an electrochemical reaction [3]. Since the method requires differentiation it is rather sensitive to high frequency noise present in the signal $x(t)$. In addition, it is not applicable to control nonoscillating states, e.g. to switch the system from an originally stable steady state x_{0S} to an USS, because $dx_{0S}/dt = 0$.

Another adaptive method for stabilizing USS employs either low-pass [4, 5, 6, 7] or high-pass [8] RC filters in the feedback loop. Provided the cut-off frequency of the RC filter is low enough, the voltage across the capacitor asymptotically approaches the USS

and therefore can be used as a reference point in the proportional feedback. The method has been successfully applied to several experimental systems, including electrical circuits [4, 5, 6] and lasers [7, 8].

However, the techniques using conventional filters are restricted to only unstable nodes and unstable spirals. They are unable to stabilize saddle type states (USS with an odd number of real positive eigenvalues). To overcome this odd number limitation an unstable filter has been suggested by Pyragas *et al.* [9] and demonstrated to stabilize saddle points in several mathematical models [9, 10, 11] also in experiments with electrochemical oscillator [9, 10] and Duffing-Holmes type electronic oscillator [11].

A challenging problem in practical application of various types of dynamical controllers are unavoidable latencies in the feedback control loops [12, 13, 14, 15, 16], especially in fast experimental systems. In particular, the unstable filter controller, as we show later, is extremely sensitive to parasitic phase lag. Latency decreases the range of feedback gains over which control is achieved. Eventually longer latency times can totally destroy the control algorithm and give rise to various undesirable instabilities. In time-delay dynamical systems this problem can be overcome by choosing a proper point in the system for applying the feedback [17]. Unfortunately, this nice idea seems to be not applicable to other dynamical systems. A straightforward way to fight the latencies in general is to insert a signal predictor [18] in the feedback loop, compensating parasitic time lag. However, electronic signal predictors are rather complicated devices requiring fine tuning of the circuit elements.

In this paper, we suggest to use two filters in parallel, namely an unstable RC filter and a stable RC filter to stabilize saddle type USS, to overcome the problem of latencies in the feedback loop.

2. Mathematical Model

Let us consider a dynamical system is given by

$$\ddot{x} + b\dot{x} + F(x) = 0. \quad (1)$$

or in a more convenient form

$$\dot{x} = y, \quad (2)$$

$$\dot{y} = -F(x) - by. \quad (3)$$

Here b is the damping coefficient, $F(x)$ is a nonlinear function (in general unknown). The system has at least one steady state $(x_0, y_0) = (x_0, 0)$. Here x_0 is found from an algebraic equation $F(x_0) = 0$. In the case

$$\left. \frac{dF}{dx} \right|_{x=x_0} \equiv F'(x_0) < 0 \quad (4)$$

the steady state $(x_0, 0)$ is a saddle. Let us apply an unstable filter based controller taking into account possible latency (inertia) in the feedback loop:

$$\dot{x} = y, \quad (5)$$

$$\dot{y} = -F(x) - by + z, \quad (6)$$

$$\dot{u} = \omega_1(u - x), \quad (7)$$

$$\tau \dot{z} = k(u - x) - z. \quad (8)$$

Here k is the control gain, ω_1 is the cut-off frequency of the unstable filter, Eq. (8) represents in the simplest form the latency effects characterized by normalized time lag τ . To check the stability properties we linearize Eqs. (5-8) around the steady state:

$$\dot{x} = y, \quad (9)$$

$$\dot{y} = -F'(x_0)x - by + z, \quad (10)$$

$$\dot{u} = \omega_1(-x + u), \quad (11)$$

$$\tau \dot{z} = k(-x + u) - z. \quad (12)$$

and analyze its characteristic equation. If the latency is neglected ($\tau = 0$) the characteristic equation reads:

$$\lambda^3 + (b - \omega_1)\lambda^2 + (k - 1 - b\omega_1)\lambda + \omega_1 = 0. \quad (13)$$

Here and further we assume $F'(x_0) = -1$ to avoid cumbersome coefficients (in the case of the Duffing–Holmes type nonlinear function $F(x) = -x + x^3$ and $x_0 = 0$ the '-1' is an exact value). For $\tau > 0$ the characteristic equation becomes more complicated:

$$\begin{aligned} \lambda^4 &+ (b + 1/\tau - \omega_1)\lambda^3 \\ &+ (b/\tau - 1 - b\omega_1 - \omega_1/\tau)\lambda^2 \\ &+ (k/\tau - 1/\tau + \omega_1 - b\omega_1/\tau)\lambda + \omega_1/\tau = 0. \end{aligned} \quad (14)$$

In order to find the threshold k_{th} and the optimal k_{opt} control gains we have solved Eq. (13) and Eq. (14) numerically (Fig. 1a,b). General view of the (a) and (b) plots looks very alike, however detailed insets reveal quite different features. In plot (a) for $k > k_{th} \approx 1.1$ all the $\text{Re}\lambda$ are negative indicating stabilization of the saddle point. The optimal feedback gain providing the fastest control is $k_{opt} \approx 1.3$. However the convergence is very slow, given by $\text{Re}\lambda \approx -0.003$.

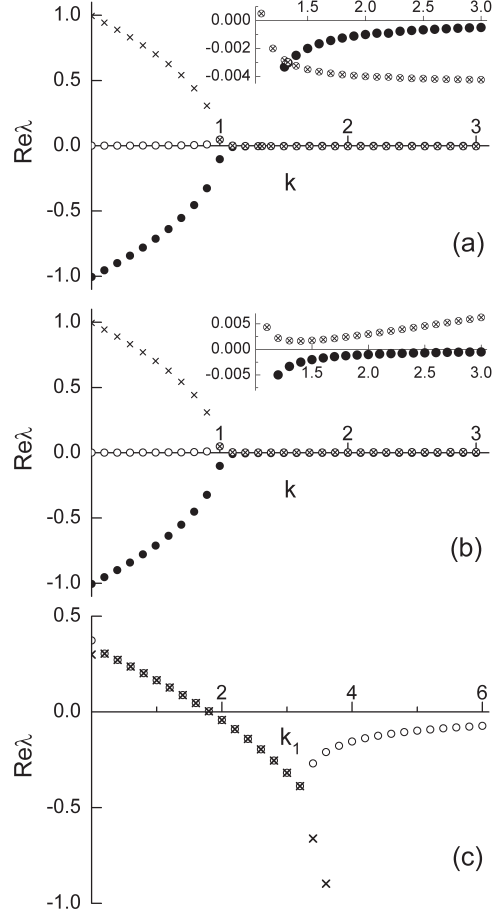

Figure 1: Real parts of the largest eigenvalues versus the control gain k_1 for $b = 0.01$. (a) from Eq. (13) with $\omega_1 = 0.001$, (b) from Eq. (14) with $\omega_1 = 0.001$, $\tau = 0.007$, (c) from Eq. (26) with $\omega_1 = 0.3$, $\tau = 0.007$, $\omega_2 = 7$, $k_2 = 17$. The set of the control parameters, ω_1 , ω_2 , and k_2 is somewhat arbitrary and empirical.

While in plot (b) the largest $\text{Re}\lambda$ is positive. Thus, even small time lag of only $\tau = 0.007 \ll 1$ destroys the stabilization.

Now we introduce in parallel to the unstable filter a stable high-pass filter:

$$\dot{x} = y, \quad (15)$$

$$\dot{y} = -F(x) - by + z, \quad (16)$$

$$\dot{u} = \omega_1(u - x), \quad (17)$$

$$\dot{v} = \omega_2(x - v), \quad (18)$$

$$\tau \dot{z} = k_1(u - x) + k_2(v - x) - z. \quad (19)$$

Here v is the dynamical variable of the stable filter, ω_2 is its cut-off frequency. Linearization about the initially unstable steady state yields:

$$\dot{x} = y, \quad (20)$$

$$\dot{y} = -F'(x_0)x - by + z, \quad (21)$$

$$\dot{u} = \omega_1(-x + u), \quad (22)$$

$$\dot{v} = \omega_2(x - v), \quad (23)$$

$$\tau \dot{z} = -(k_1 + k_2)x + k_1u + k_2v - z. \quad (24)$$

The corresponding characteristic equation with the same assumption of $F'(x_0) = -1$ for $\tau = 0$ reads

$$\begin{aligned} \lambda^4 &+ (b + \Delta\omega)\lambda^3 + (b\Delta\omega - \omega_1\omega_2 + k - 1)\lambda^2 \\ &+ (-\Delta\omega - b\omega_1\omega_2 + \omega_2k_1 - \omega_1k_2)\lambda \\ &+ \omega_1\omega_2 = 0. \end{aligned} \quad (25)$$

Here $\Delta\omega = \omega_2 - \omega_1$, $k = k_1 + k_2$. For $\tau > 0$ the characteristics equation becomes the 5th order one:

$$\begin{aligned} \lambda^5 &+ (1/\tau + b - \Delta\omega)\lambda^4 \\ &+ [b/\tau + (1/\tau + b)\Delta\omega - \omega_1\omega_2 - 1]\lambda^3 \\ &+ [(b/\tau - 1)\Delta\omega - (1/\tau + b)\omega_1\omega_2 + (k - 1)/\tau]\lambda^2 \\ &+ [(1 - b/\tau)\omega_1\omega_2 + (\omega_2k_1 - \omega_1k_2 - \Delta\omega)/\tau]\lambda \\ &+ \omega_1\omega_2/\tau = 0. \end{aligned} \quad (26)$$

Numerical solutions of Eq. (26) are presented in Fig. 1c. In contrast to the plots (a) and (b) the plot (c) clearly exhibits deep negative $\text{Re}\lambda$ above threshold gain $k_{th} \approx 1.8$. The optimal gain value $k_{opt} \approx 3.2$ provides $\text{Re}\lambda \approx -0.4$. We intentionally do not present here the figure for zero latency from Eq. (25), since the results coincide with the plot (c) within 0.5%.

3. Experiment

Circuit diagram is shown in Fig. 2. An electronic Duffing-Holmes type oscillator is composed of the elements OA1, R1...R3, R, L, C, D1, and D2. It is a simplified version of the Young-Silva oscillator [19], used

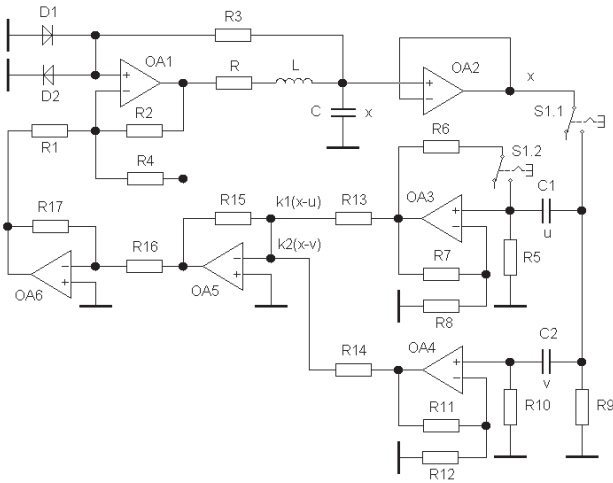

Figure 2: Nonlinear circuit with a controller. $R_1 = R_2 = R_3 = R_6 = R_7 = R_8 = R_9 = R_{11} = R_{12} = R_{15} = R_{16} = R_{17} = 10 \text{ k}\Omega$, $R_4 = 100 \text{ k}\Omega$.

to demonstrate stabilization of saddle [11] by means of Pyragas' method. The rest of the circuit in the feedback loop is a controller. The OA2 stage is a buffer. The OA3 and OA4 stages are an unstable and a stable first order high-pass filters, respectively. The OA5 based inverting adder conjoins the both filters. Finally the OA6 stage is an inverter. The control gains of the two filters are given by $k_1 = (R_7/R_8 + 1)(R_{15}/R_{13})$ and $k_2 = (R_{11}/R_{12} + 1)(R_{15}/R_{14})$. Note that the OA3 stage is a negative impedance converter. It introduces in the circuit negative resistance R^- (in the case $R_6 = R_7$ the $R^- = -R_8$), thus making the filter unstable. The normalized cut-off frequency of the unstable filter is $\omega_1 = \sqrt{LC}/|R^*|C_1$ with $R^* = -R_8||R_5 = -R_5R_8/(R_5 - R_8)$. While the normalized frequency of the stable filter is simply $\omega_2 = \sqrt{LC}/R_{10}C_2$. Location of the unstable steady state can be varied by means of the external voltage source V^* via resistor R4. The following circuit elements have been used in the experiment: $L = 19 \text{ mH}$, $C = 470 \text{ nF}$, $R = 2 \text{ }\Omega$. $\omega_0 = 1/\sqrt{LC} = 10^4 \text{ s}^{-1}$, $\rho = \sqrt{L/C} = 200 \text{ }\Omega$, damping parameter $b = R/\rho = 0.01$. $R_5, R_{10}, R_{13}, R_{14}, C_1, C_2$ are adjustable values and are specified in the caption to Fig. 3. The operational amplifiers OA1...OA6 are the op07 type integrated circuits, the diodes D1 and D2 are the 1N4148 type devices. The S1.1 - S1.2 is an electronically operated double switch, used for closing the feedback loop.

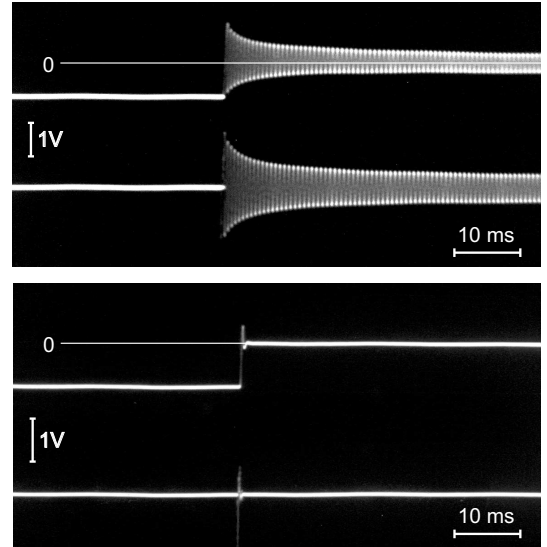

Figure 3: Experimental control of the Duffing-Holmes oscillator; $R_5 = 20 \text{ k}\Omega$, $R_{10} = 1.4 \text{ k}\Omega$, $V^* = 0$. Top: unstable filter only; $C_1 = 5\mu\text{F}$ ($\omega_1 = 0.001$), $R_{13} = 12 \text{ k}\Omega$ ($k_1 = 1.7$). Bottom: conjoint filter; $C_1 = 15 \text{ nF}$ ($\omega_1 = 0.3$), $R_{13} = 5 \text{ k}\Omega$ ($k_1 = 4$), $C_2 = 10 \text{ nF}$ ($\omega_2 = 7$), $R_{14} = 1.2 \text{ k}\Omega$ ($k_2 = 17$). Upper traces in both photos is the output of the oscillator, lower traces are the control signals taken from the OA6.

The unstable controller (Fig. 3,top) fails to stabilize the unstable steady state, but gives rise to periodic oscillations as predicted by $\text{Re}\lambda > 0$. While the conjoint controller (Fig. 3,bottom) robustly switches the system from a stable steady state to an originally unstable one. The control force vanishes after short transient. We note, that double filter technique for stabilizing steady states has been described in [20], where the both filters are the second order Wien-bridge circuits. Thus, the overall controller is a fourth order system. Moreover, the filters are stable ones, therefore are not applicable to stabilize saddles.

Acknowledgments

The work was supported by the Lithuanian State Science and Studies Foundation (contract T-72/09).

References

- [1] S. Bielawski, M. Bouazaoui, D. Derozier, P. Glorieux, "Stabilisation and characterization of unstable steady state in a laser," *Phys. Rev. A* vol.47, pp.3276–3279, 1993.
- [2] G. A. Johnson, E. R. Hunt, "Derivative control of the steady state in Chua's circuit driven in the chaotic region," *IEEE Trans. Circuit Syst.* vol.40, pp.833–834, 1993.
- [3] P. Parmananda, M. A. Rhode, G. A. Johnson, R. W. Rollins, H. D. Dewald, A. J. Markworth, "Stabilisation of unstable steady state in an electrochemical system using derivative control," *Phys. Rev. E*, vol.49, pp.5007–5013, 1994.
- [4] N. F. Rulkov, L. S. Tsimring, H. D. I. Abarbanel, "Tracking unstable orbits in chaos using dissipative feedback control," *Phys. Rev. E*, vol.50, 314–324, 1994.
- [5] A. Namajūnas, K. Pyragas, A. Tamaševičius, "Stabilisation of Unstable Steady State in a Mackey-Glass System," *Phys. Lett. A*, vol.204, pp.255–262, 1995.
- [6] A. Namajūnas, K. Pyragas, A. Tamaševičius, "Analog Techniques for Modeling and Controlling the Mackey-Glass System," *Int. J. Bif. Chaos*, vol.7, 957–962, 1997.
- [7] A. S. Schweinsberg, U. Dressler, "Characterization and stabilization of the unstable fixed points of a frequency doubled Nd:YAG laser," *Phys. Rev. E*, vol.63, 056210, 2001.
- [8] M. Ciofini, A. Labate, R. Meucci, M. Galanti, "Stabilisation of unstable fixed points in the dynamics of a laser with feedback," *Phys. Rev. E*, vol.60, pp.398–402, 1999.
- [9] K. Pyragas, V. Pyragas, I. Z. Kiss, J. L. Hudson, "Stabilizing and tracking unknown steady states of dynamical systems," *Phys. Rev. Lett.*, vol.89, 244103, 2002.
- [10] K. Pyragas, V. Pyragas, I. Z. Kiss, J. L. Hudson, "Adaptive control of unknown unstable steady states of dynamical systems," *Phys. Rev. E* vol.70, 026215, 2004.
- [11] A. Tamaševičius, E. Tamaševičiūtė, G. Mykolaitis, S. Bumelienė, "Switching from stable to unknown unstable steady states of dynamical systems," *Phys. Rev. E*, vol.78, 026205, 2008.
- [12] D. W. Sukow, M. E. Leich, D. J. Gauthier, J. E. S. Socolar, "Controlling chaos in a fast diode resonator using extended time-delay autosynchronization: experimental observations and theoretical analysis," *Chaos*, vol.7, 560–576, 1997.
- [13] W. Just, D. Reckwerth, E. Reibold, H. Benner, "Influence of control loop latency on time-delayed feedback control," *Phys. Rev. E*, vol.59, 2826–2829, 1999.
- [14] P. Hövel, J. E. S. Socolar, "Stability domains for time delay feedback control with latency," *Phys. Rev. E*, vol.68, 036206, 2003.
- [15] P. Hövel, E. Schöll, "Control of unstable steady states by time-delayed feedback methods," *Phys. Rev. E*, vol.72, 046203, 2005.
- [16] S. Schikora, P. Hövel, H. J. Wünche, E. Schöll, F. Henneberger, "All-optical noninvasive control of unstable steady states in a semiconductor laser," *Phys. Rev. Lett.*, vol.97, 213902, 2006.
- [17] J. N. Blakely, L. Illing, D. J. Gauthier, "Controlling fast chaos in delay dynamical systems," *Phys. Rev. Lett.*, vol.92, 193901, 2004.
- [18] M. Meškauskas, A. Tamaševičius, K. Pyragas, "Analogue signal predictor: frequency-domain analysis," *Int. J. Bif. Chaos*, vol.17, pp.3715–3719, 2007.
- [19] Y.-Ch. Lai, A. Kandangath, S. Krishnamoorthy, J. A. Gaudet, A. P. S. de Moura, "Inducing chaos in electronic circuits by resonant perturbations: theory and experiments," *Phys. Rev. Lett.*, vol.94, 214101, 2005.
- [20] A. Ahlborn, U. Parlitz, "Chaos control using notch filter feedback," *Phys. Rev. Lett.*, vol.96, 034102, 2006.