

# Multiband Combo Antenna for LTE/GSM/UMTS Bands

#Sangbong Sung<sup>1,2</sup>, Jaeho Lee<sup>1</sup>, Seunghwan Kim<sup>1</sup>, and Youngoo Yang<sup>2</sup>

<sup>1</sup> Antenna R&D Group, Samsung Electronics, Suwon, S. Korea, ssbb.sung@samsung.com

<sup>2</sup> Department of DMC Engineering, Sungkyunkwan Univ., Suwon, S. Korea, yang09@skku.edu

## Abstract

A novel hexa-band combo antenna for the mobile phone applications is presented. The antenna, which comprises folded monopole, printed loop, and parasitic element, operates over the six frequency bands, such as LTE700, GSM850, GSM900, GSM1800, PCS1900, and UMTS2100.

**Keywords :** Multiband antenna, LTE, Combo antenna, Hexa-band antenna.

## 1. Introduction

Since the long term evolution (LTE) services are emerging, it is required to be able to cover the LTE band in addition to the frequency bands for the existing services for the mobile devices [1].

Furthermore, as the 700MHz band was assigned to the LTE, which is a representative 4<sup>th</sup>-generation (4G) wireless communication system, it has been highly required to design multiband antennas that can cover the hexa-bands, such as LTE700, GSM850, GSM900, GSM1800, PCS1900, and UMTS2100. However, it is difficult to design the hexa-band antenna because of size limitation for the printed circuit board (PCB) and antenna carrier. Therefore, branched or folded monopole has been popularly adopted for such a multiple band antenna including the LTE band because it forces the current to flow along the curved and longer path, which makes it have the lower resonant frequency [2]. In addition, monopole antenna has wider bandwidth than that of a planar inverted-F antenna (PIFA) which has been widely adopted in practical wireless devices [3].

In this paper, we proposed a multiband combo antenna consisting of folded monopole, printed loop, and parasitic element. The folded monopole antenna has a fundamental resonant mode at about 800MHz and also has a wide bandwidth by incorporating a printed loop antenna and an additional series C matching network. In addition, the printed loop antenna has a wide upper band because it incorporates the monopole antenna's second resonant mode and parasitic element [4]. The proposed antenna operates in the hexa-bands, such as LTE700 (746-787MHz/Band13), GSM850 (824-894MHz), GSM900 (890-960MHz), GSM1800 (1710-1880MHz), PCS1900 (1850-1990MHz), and UMTS2100 (1920-2170MHz/Band 1).

## 2. Design Considerations

The proposed combo antenna consists of three parts: folded monopole antenna on the antenna carrier, printed antenna on the PCB, and parasitic element from the PCB ground.

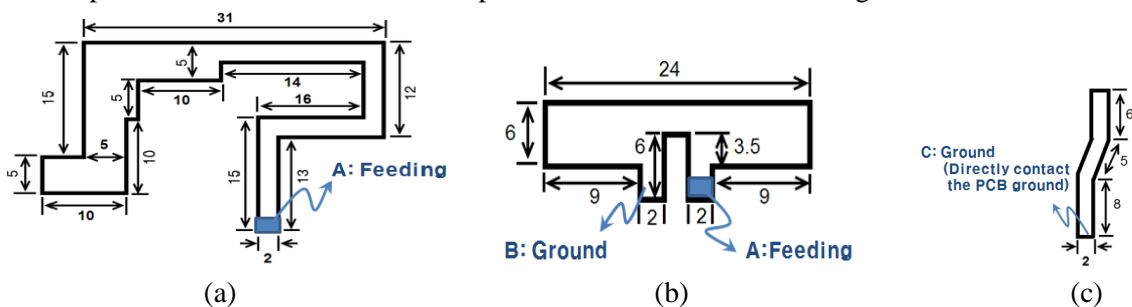

Fig. 1. The structures of the proposed multiband combo antenna: (a) Folded monopole antenna, (b) Printed loop antenna, and (c) Parasitic element.

Fig.1 (a) shows the folded monopole antenna for the low frequency bands. It is designed on the antenna carrier which is based on acrylonitrile-butadiene-styrene (ABS) material whose dielectric constant and loss tangent are 2.3 and 0.05, respectively. Fig.1 (b) shows the printed loop antenna for the high frequency bands. It is directly printed on the PCB without ground, which is under the folded monopole antenna. Fig.1 (c) presents the parasitic element which controls high frequency bandwidth. It has a contact into a PCB ground and is designed at a side of the folded monopole antenna with a gap of 3mm to the antenna carrier. The monopole antenna and printed loop antenna share an input feeding point A and parasitic element connect to PCB ground directly point C.

Fig. 2 depicts a 3-dimensional geometry of the proposed combo antenna with the antenna carrier and ground plane. The dimension of the PCB,  $55 \times 92\text{mm}^2$  including a non-ground region of  $55 \times 24 \text{mm}^2$ , is selected based on commercially available mobile phones. It is implemented using FR4 substrate with a thickness of 1.2mm and a relative permittivity of 4.0. It also has ground planes of a size of  $35 \times 68\text{mm}^2$  on both sides of the PCB. Antenna carrier, based on ABS, has a dimension of  $50 \times 17 \times 5(t) \text{mm}^3$ .

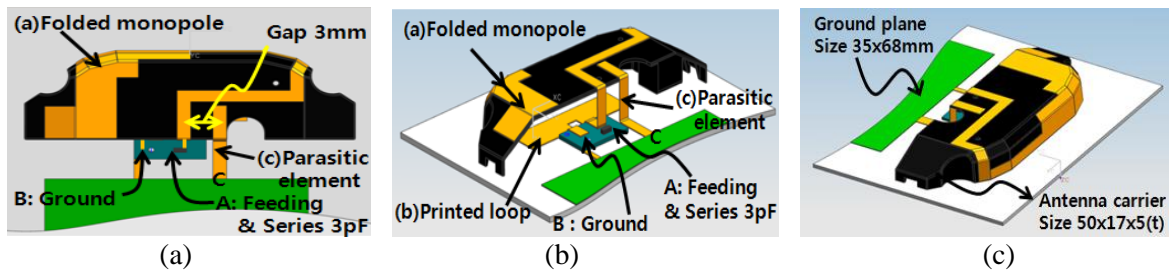

Fig. 2. Geometry of the proposed multiband combo antenna: (a) Top view, (b) and (c) 3D view

If there is only a monopole antenna, single mode is generated for the lower GSM band and the input impedance, plotted on the smith chart, shows that it is capacitive for the LTE700 band (A1:  $16.5-j31.7$  at 754MHz, as shown in Fig. 3 (a)). However, when the printed loop antenna is added under the folded monopole, the capacitive reactance is compensated (A2:  $27.6+j104$  at 754MHz, as shown in Fig. 3(b)) and it is further optimized by adding a series capacitor of 3pF for the low frequency bands (see Fig. 3(c)). As a result, the proposed combo antenna has a wide operating band which covers LTE700 (Band13) / GSM850 / GSM900 (746~960MHz).

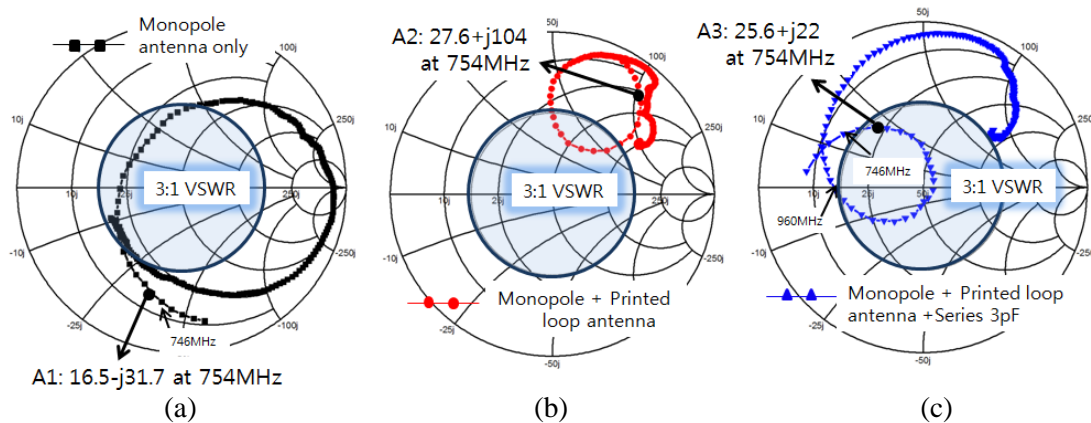

Fig. 3. Measured input impedances on the Smith chart: (a) monopole antenna only, (b) monopole antenna and printed loop antenna, and (c) monopole antenna, printed loop antenna, and a series capacitor of 3pF

The printed loop antenna is operating at the high frequency bands. It is found that the bandwidth is broadened because the printed loop antenna and folded monopole antenna's second resonant mode at about 1800MHz coincide. However, in this case, it doesn't still comply for the 3:1 VSWR (about 6dB return loss) for the target high frequency band (1710~2170MHz). So, we added a parasitic element which has a contact with the PCB ground. After adding this parasitic element of 19mm length, the high frequency bandwidth was controlled and eventually broadened (see Fig. 4).

### 3. Measurements and Discussion

The proposed combo antenna with a dimension given in Fig. 1 was implemented and evaluated. Fig. 4(a) shows a comparison of the measured return losses between the proposed antenna (folded monopole, printed loop, and parasitic element), and the case without parasitic element (only folded monopole and printed loop). Effect of the parasitic elements' lengths from 15 to 19 mm on the measured return losses can be observed from Fig. 4(b).

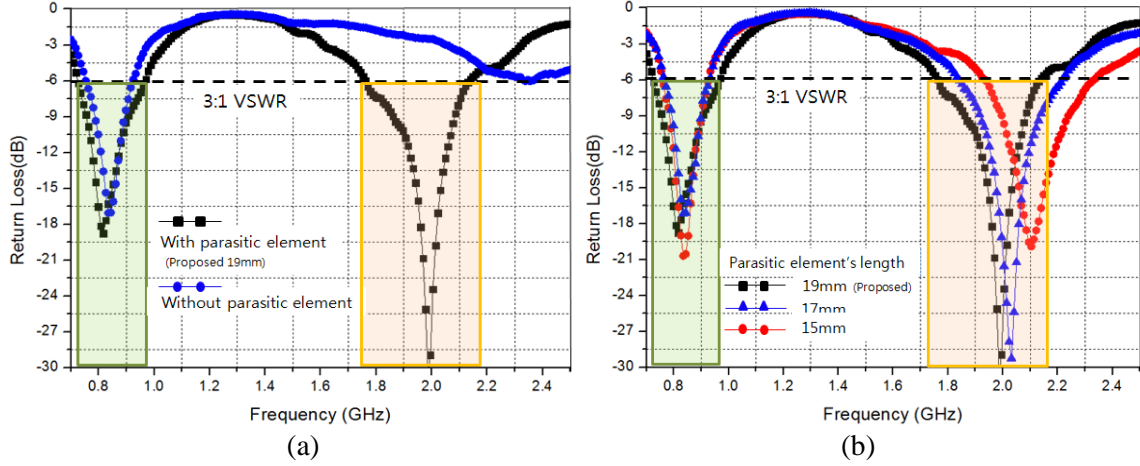
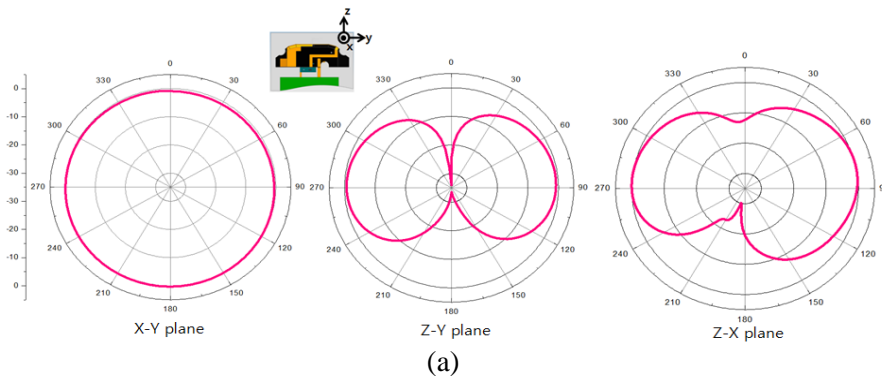

Fig.4. Comparison of the measured return losses: (a) the proposed antenna with a parasitic element (folded monopole, printed loop, and parasitic element) vs. the antenna without parasitic element (only folded monopole and printed loop), (b) Return losses according to the length of the parasitic element

The bandwidths of the antenna for both lower and upper bands are greatly enhanced due to the integration of the folded monopole antenna, printed loop antenna, and parasitic element together. After all, the hexa-band operation is achieved. Table 1 presents the experimental results for the proposed combo antenna. The measured average radiation efficiencies are 40, 60 and 55% for the LTE700 (band 13), GSM850, and GSM900 at the low frequency bands and 53, 66 and 62% for the GSM1800, PCS1900, UMTS2100 at the high frequency bands, respectively. Fig. 5 plots the measured radiation patterns from the anechoic chamber for 849, 1920, and 2110MHz.

TABLE 1. MEASURED AVERAGE EFFICIENCIES, AVERAGE GAINS, AND PEAK GAINS

Service Band	LTE 700	GSM 850	GSM 900	GSM 1800	PCS 1900	UMTS2100
Average Efficiency (%)	40	60	55	53	66	62
Average Gain (dBi)	-4.05	-2.20	-2.66	-2.82	-1.82	-2.13
Peak Gain (dBi)	-0.80	1.45	0.33	-0.50	1.19	1.59



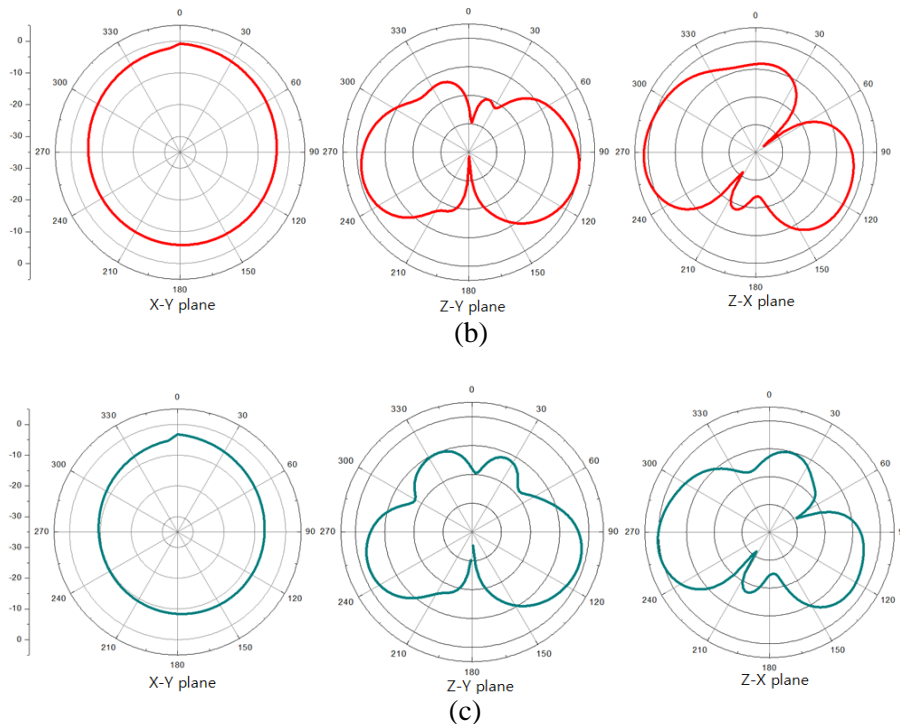

Fig. 6 Measured radiation patterns at (a) 849MHz, (b) 1920MHz, and (c) 2110MHz

It is found that monopole-like radiation patterns are observed at the lower bands and more variations and some nulls are observed at the upper bands. In addition, omni-directional radiation patterns in X-Y plane are obtained at the lower and upper bands.

#### 4. Conclusion

In this paper, a combo antenna, which covers the six representative wireless communication bands, including LTE700 (Band 13), has been proposed. The combo antenna formed by a folded monopole antenna, printed loop antenna, and parasitic element. It has been shown that the folded monopole antenna for the only lower GSM band works from LTE (Band 13) to GSM900 by good impedance matching through the printed loop antenna and a simple series C matching method. In addition, the combination of the printed loop antenna, folded monopole antenna's second resonant mode, and parasitic element attained wide bandwidth at the upper frequency bands. The parasitic element, which has a contact with the PCB ground, could adjust the upper frequency bandwidth.

The proposed combo antenna was fabricated and evaluated especially for return loss, antenna gain and radiation pattern. Good radiation characteristics over the hexa-bands, including LTE700 (Band 13), was obtained. It was proved that the proposed antenna is suitable for 4G smart phones which are capable of multiband operation.

#### References

- [1] S. Sesia, I. Toufik, and M. Baker, LTE-The UMTS Long Term Evolution: From Theory to Practice, Wiley, New York, 2009.
- [2] J. L. Volakis, C. Chen, and K. Fujimoto, Small Antennas : Miniaturization Techniques & Applications, Mc Graw Hill, New York, pp 131-208, 2010.
- [3] K. L. Wong, Planar Antenna for Wireless Communications, Wiley Inter-Science, New York, 2003.
- [4] C. Y. Huang and P. Y. Chiu, "Dual-band monopole antenna with shorted parasitic element", Electronics Letters, vol. 41, no. 21, pp. 1154-1155, 2005.