

# Discussion on Tapered Amplitude Multiple Beam Forming Networks for Array Antenna Design

Nelson J. G. Fonseca<sup>1,2</sup>

<sup>1</sup> Antenna and Sub-Millimetre Wave Section, European Space Agency (ESA/ESTEC)  
Keplerlaan 1, P.O. Box 299, 2200AG Noordwijk (ZH), The Netherlands  
[nelson.fonseca@esa.int](mailto:nelson.fonseca@esa.int)

<sup>2</sup> Université de Toulouse; UPS, INSA, INP, ISAE; UT1, UTM, LAAS  
F-31077 Toulouse cedex 4, France

## Abstract

This paper compares two different topologies of tapered amplitude multiple beam forming networks for linear array antenna design, highlighting their respective advantages and limitations. The comparison is supported by theoretical results, including internal losses, complexity, etc. and is illustrated with specific examples.

**Keywords:** Array Antennas Multiple Beam Forming Networks

## 1. Introduction

Multiple Beam Forming Networks (MBFN) are particularly interesting in array antenna design as they enable to produce several beams from a same radiating aperture [1]. It is a sub-system composed of elementary parts, e.g. couplers, hybrids, phase-shifters, etc., combined in such a way to connect  $M$  beam ports with the  $N$  ports of an  $N$ -element array antenna. Typical applications include multiple beam coverage for Space-Division Multiple Access (SDMA) implementation and electronically scanned beams. Some well known examples of MBFN are the Butler [2] and the Blass [3] matrices. These solutions have the particularity that each beam port is connected to each array element. In this paper, we discuss solutions that connect each beam port to a subset of array elements. This is well-adapted to multiple beam antennas in a focal array fed reflector configuration. Often, these focal arrays are based on tailored beam forming networks, the overlap between adjacent beams depending on the reflector geometry and beam crossover requirements.

In this paper, we focus on two generic topologies. The first one is known as Coherently Radiating Periodic Structure BFN (CORPS-BFN or C-BFN). It was first introduced in [4] for phased arrays, but was later applied to focal array design [5]. C-BFN is characterised by an alternating arrangement of power dividers and power combiners (which are actually the same component used in different operation modes). This is in fact a generalisation of the structure used in [2] to produce cosine and cosine-squared illuminations. The purpose of this paper is to compare this structure with another one based on parallel Beam Forming Networks (BFN). A good description of such a structure can be found in [6]. This second structure, referred to as parallel BFN is composed of a first section of power dividers followed by a second section of power combiners. This second structure is much more flexible than the first one, so it can actually be adapted to produce the very same amplitude and phase distributions as the first one. Accordingly, we considered worth comparing these two structures to identify their respective advantages and limitations, providing recommendations to select the most suited topology for a given application.

## 2. General Description and Performance Evaluation

As already mentioned, C-BFNs are characterised by an alternating arrangement of power dividers and power combiners. Figure 1(a) provides an example of C-BFN. Due to the elementary component characteristics, the power delivered at a beam port distributes itself within a triangular area (highlighted in Figure 1(a) for the beam port 2) toward corresponding output ports. The

topology naturally produces a Gaussian-like amplitude in-phase distribution. The parallel BFN topology is composed of a power dividing section, connected to each beam port, followed by a power combining section connected to each array element. Figure 1(b) gives an example of such a structure. The power dividing section is 1:4 and can be realised using two layers of standard power dividers (first layer is actually just a balanced power divider, while second layer has to be two unbalanced power dividers to produce the same Gaussian-like amplitude distribution as a C-BFN), while the power combining section 3:1 requires two power combiners, a balanced one and a 1/3-2/3 unbalanced one.

For proper operation of these two structures, the elementary component needs to be matched at all ports, which introduces losses in power combining operation mode. Losses actually appear when power combination is unbalanced. Losses of a C-BFN can be derived using the simple matrix representation described in [7]. These losses vary with the number of layers, which is equal to  $M-N$ . The number of components can easily be derived based on simple formulas and is equal to  $N^2-M^2$ . In the case of parallel BFN, losses only appear in the  $M:1$  combiner section. They depend on the overlap between adjacent beams. Losses in parallel BFN can never exceed  $10 \times \log_{10}(M)$ , which corresponds to the losses of a power combining section combining all the beams, assuming that all signals are incoherent. The number of components in that case is not defined with a simple formula. As it can be seen in Figure 1(b), the parallel BFN also induces some electrical path crossovers. For better comparison, we provide in Table 1 and Table 2 a detailed comparison of losses and number of components for the two types of BFNs and for different number of layers, as defined in the case of C-BFN. Table 1 corresponds to a 3-beam BFN while Table 2 provides results for a 4-beam BFN. These tables are illustrated by Figure 1 and 2 with specific examples of equivalent topologies. Figure 1 compares the C-BFN and parallel BFN topologies of a 3-beam BFN feeding a 6-element linear array (corresponding to the 3-layer case in Table 1), while Figure 2 compares the same topologies in the case of a 4-beam BFN feeding also a 6-element linear array (corresponding to the 2-layer case in Table 2).

### 3. Discussion

Comparing the two results, it appears that C-BFN and the corresponding parallel BFN are actually the same when they reduce to the elementary case of a 1-layer C-BFN. Losses in C-BFN increase as a logarithmic function, while losses in parallel BFN progress by steps as the beam overlap at the output ports increases to reach the maximum value defined above, function only of the number of beams produced. The results indicate that for low numbers of layers, the C-BFN topology always provides the same or lower losses when compared to the equivalent parallel BFN. But as the number of layers increases, C-BFN becomes at one point worst than its parallel BFN equivalent, and the difference keeps on increasing with the number of layers. Concerning the number of components, it is interesting to note that they are actually equal up to a certain number of layers that varies with the number of beams produced. For instance, in the case of the 3-beam BFN, the difference appears above 2 layers while in the case of the 4-beam BFN, the number of components is the same up to 3 layers. Parallel BFN has always the same or less components when compared to the equivalent C-BFN. But for a fair comparison, one has to take into account the fact that parallel BFNs induce crossovers. The number of crossovers increases exponentially with the number of layers, resulting in a complex design if a planar implementation is required.

Consequently, the main conclusions that can be drawn for this comparison is that C-BFN are attractive as long as the number of layers is small. This result is in line with the one previously published in [7], indicating that losses in C-BFN tend to make it unattractive for large array designs. This comparison also indicates that C-BFN could be preferred when a planar realisation is required by the targeted application, for instance for linear antenna design with integrated BFN. But most of the times, the array antenna is not linear but planar, allowing more freedom in the BFN topology. This comforts the general conclusion that parallel BFNs should be preferred to design large phased array antennas (this is actually the BFN topology used for most of the phased array antennas implemented in space applications) while C-BFN could have more potential in focal array fed reflector antenna configurations or for linear array antenna applications such as 1-D beam scanning antennas, as long as the array size remains relatively small.

Table 1: Comparison in the case of a 3-beam BFN

Number of layers	Parallel BFN			C-BFN	
	Number of components	Number of crossovers	Losses	Number of components	Losses
1	7	0	3.01dB	7	3.01dB
2	16	2	4.77dB	16	4.26dB
3	21	7	4.77dB	27	5.05dB
4	28	15	4.77dB	40	5.63dB

Table 2: Comparison in the case of a 4-beam BFN

Number of layers	Parallel BFN			C-BFN	
	Number of components	Number of crossovers	Losses	Number of components	Losses
1	9	0	3.01dB	9	3.01dB
2	20	3	4.77dB	20	4.26dB
3	33	11	6.02dB	33	5.05dB
4	40	25	6.02dB	48	5.63dB
5	47	45	6.02dB	65	6.09dB

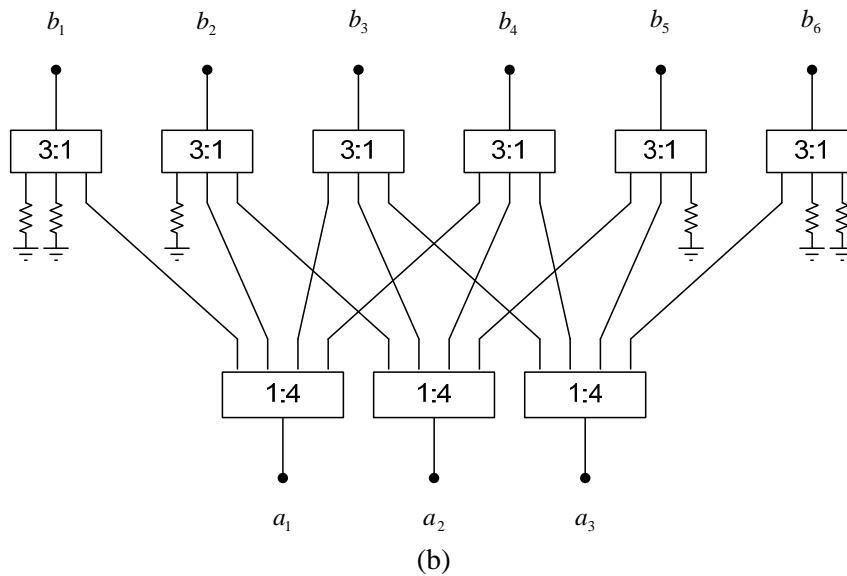
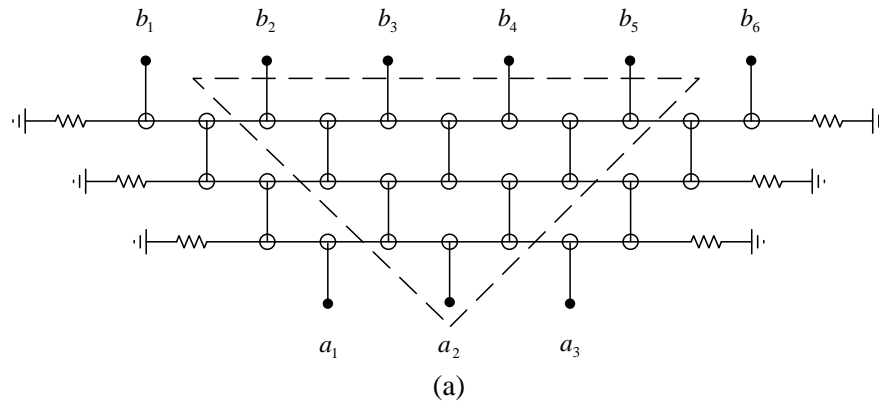

Figure 1: (a) 3x6 C-BFN and (b) equivalent parallel BFN.

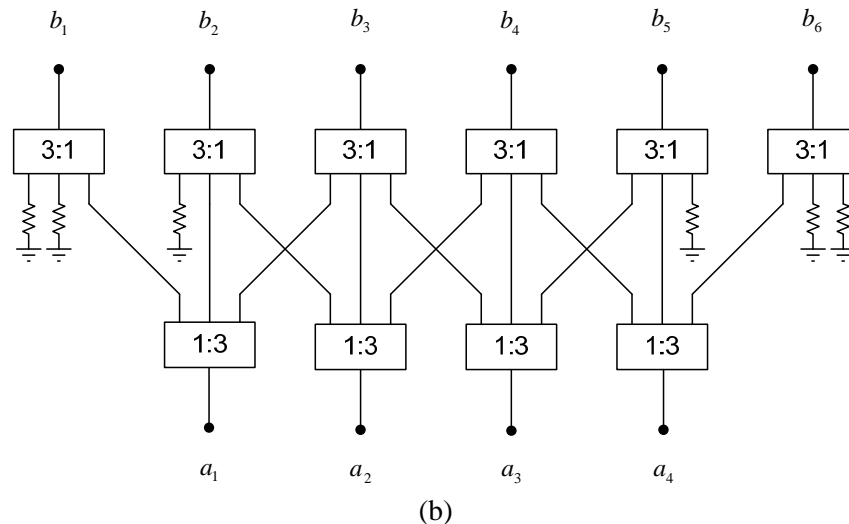
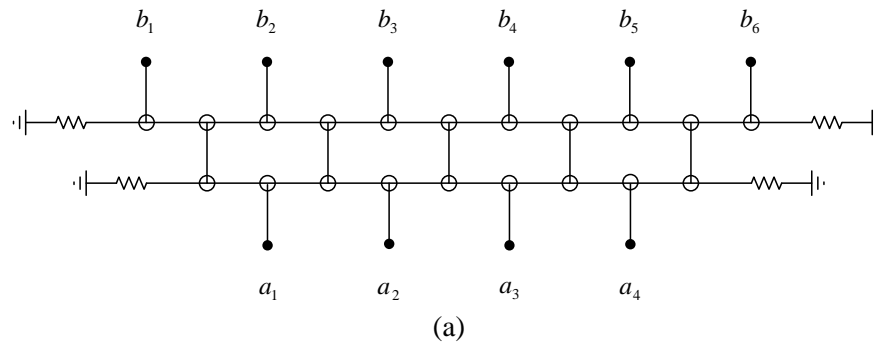

Figure 2 : (a) 4x6 C-BFN and (b) equivalent parallel BFN.

## References

- [1] R.C. Hansen, Phased Array Antennas – Chapter 10: Multiple-Beam Antennas, Wiley Series in Microwave and Optical Engineering, Kai Chang, Series Editor, 1998.
- [2] J. Butler, R. Lowe, “Beam-Forming Matrix Simplifies Design of Electronically Scanned Antennas,” *Electronic Design*, pp. 170-173, April 1961.
- [3] J. Blass, “Multidirectional Antenna, a New Approach to Stacked Beams,” *IRE International Conference Record*, Vol. 8, Part 1, pp. 48-50, 1960.
- [4] D. Betancourt, C. del R o, “Designing Feeding Networks with CORPS: Coherently Radiating Periodic Structures,” *Microwave and Optical Technology Letters*, Vol. 48, No. 8, pp. 1599-1602, 30 May 2006.
- [5] D. Betancourt, C. del R o, “Multi-Beam Applications of CORPS-BFN: Reflector Antenna Feeding System,” *Proc. 30<sup>th</sup> ESA Workshop on Antennas for Earth Observation, Science, Telecommunication and Navigation Space Missions*, Noordwijk, The Netherlands, pp. 287-289, 27-30 May 2008.
- [6] E.H. Kadak, “Conformal Array Beam Forming Network,” US Patent 3,868,695, 25 Feb. 1975.
- [7] N. Ferrando, N.J.G. Fonseca, “Investigations on the Efficiency of Array Fed Coherently Radiating Periodic Structure Beam Forming Network,” *IEEE Trans. Antennas and Propag.*, Vol. 59, No. 2, pp. 493-502, Feb. 2011.

## Acknowledgments

The Author would like to thank Dr. Cyril Mangenot for discussions that led to these investigations and results.