

IEICE Proceeding Series

Spike Propagation in Excitable Systems Enhanced by
Membrane-Potential-Dependent Noise

Gonzalez-Carabarin Lizeth, Tetsuya Asai, Masato Motomura

Vol. 1 pp. 640-643

Publication Date: 2014/03/17

Online ISSN: 2188-5079

Downloaded from www.proceeding.ieice.org



Spike Propagation in Excitable Systems Enhanced by Membrane-Potential-Dependent Noise

Gonzalez-Carabarin Lizeth, Tetsuya Asai and Masato Motomura

Graduate School of Information, Science and Technology, Hokkaido University
Kita 14, Nishi 9, Kita-ku, Sapporo, 060-0814, Japan
Phone: +81-11-706-7147, Fax: +81-11-706-7890

Email: lizeth@lalsie.ist.hokudai.ac.jp, asai@ist.hokudai.ac.jp, motomura@ist.hokudai.ac.jp

Abstract—

Until a few decades ago, noise was considered to be a factor that was responsible for the degradation in the performance of any electrical system, and indeed, there has been much research on the suppression of noisy signals. However, in the early 70's, a new phenomenon was observed in many physical as well as biological systems in which noise actually enhanced their performance under certain circumstances. Recently, Ochab-Marcinek *et al.* demonstrated that in myelinated axons having several intermediate nodes (known as Ranvier nodes), spike transmission initiated by sub-threshold stimuli can be enhanced by exploiting internal random fluctuations. Inspired by this work, we investigated how noise and its fluctuations enhance the performance of spike transmission in serially-connected electrically receiving sub-threshold inputs. Moreover, we also explored the effect of a membrane-potential-dependent dynamic noise as an alternative to avoiding spontaneous spike generation due to large noise fluctuations. Electrical simulations showed more than 20% increase in the transmission rate.

1. Introduction

Excitable systems are observed in a wide range of natural phenomena, such as those found in some biological structures and can be defined as a monostable system, if such a system is left unperturbed, it will continue resting, however, a strong perturbation can trigger the system to an excited state (called firing) and this response is represented by spikes (impulse-like signals). A subsequent excitation can be generated only after a certain period of time (refractory period) has elapsed. An excitable medium is constituted by segments that possess the property of excitability and are connected to each other via local coupling. Under this framework, we concentrate our attention on spike propagation through transmission lines modeled as excitable media. Usually, a transmission line consists of very low internal resistors (sub-threshold values) allowing transmission of information without any conflict; however, materials with many imperfections constitute transmission lines. Hence, one of the problems associated with transmission lines in excitable media, is the presence of high

resistance elements (supra-threshold values). According to the line model, in a non-uniform medium, a transmission line is composed of active segments, connected to each other through passive ones, so the final electrical model is similar to that found in segmented axons. On the other hand, it is known that some neurophysiological systems are able to complete several tasks even in the presence of large amount of noise, and research in this field has demonstrated the constructive and crucial role of Stochastic Resonance (RS) [2] in accomplishing some tasks for biological tissues such as those found in insect mechanoreceptors [3]. It has also been found to improve the performance of the human sensory system [4], by increasing the sensitivity to detect weak stimuli, as discussed in detail in the next section. The biological background of the work and the models used to emulate the biological system to transmit spikes have been discussed in the subsequent sections. The results of the simulation and the impact of noise amplitude on the spike propagation performance have also been presented.

2. Biological Background

One of the most common examples of excitable systems is observed in the biological neuron, where successful spike transmission must be ensured for correct communication between the neurons. Kawaguchi *et al.* [5] showed that transmission of neural information through an array of neurons, represented by sub-threshold stimuli, is assisted by uncorrelated noise with a specific amplitude. Usually conventional axons are uniform along the path, but myelinated axons, are divided into segments; separated from each other by the so-called Ranvier nodes (Fig. 1), whose main function is to enhance propagation velocity of spikes through long axons thereby saving the metabolic cost as well. Ranvier nodes can be modeled electrically as active elements separated from each other by a certain impedance. If these type of axons are electrically modeled, then we arrive at a chain of active elements connected to each other through internodal resistors, so that the entire electrical scheme of myelinated axons is similar and corresponds to the schematic of transmission lines. Moreover, the value of the internodal resistance depends on several factors such as the internodal distance and is usually represented by ran-

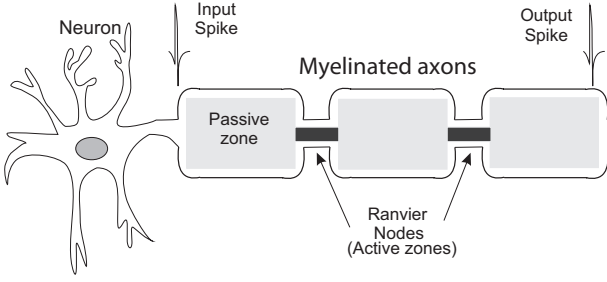

Figure 1: General scheme of myelinated axons.

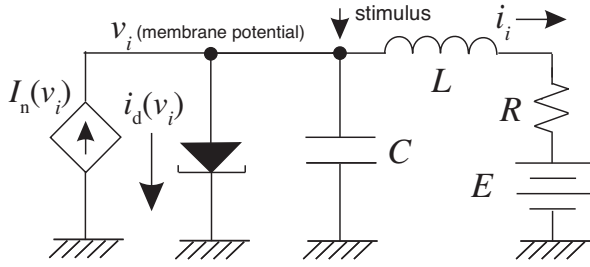

Figure 2: Noise-driven FitzHugh-Nagumo circuit.

dom values, that are sometimes large enough to reduce the spike amplitude, avoiding spike transmission. However, the interesting fact is that, actually, myelinated axons are an efficient way to transmit information even in the presence of low conductances between nodes. The question therefore arises as to how the axons successfully accomplish their task. It is well known that Ranvier nodes possess internal fluctuations due to the random opening and closing of ion channels, and research has shown that this internal noise assists sub-threshold spike transmission [1]. Moreover, it has been demonstrated that the strength of noise depends on the amplitude of the action potential [6], which actually is a key factor to avoid unwanted spikes (here, we refer to unwanted spikes as those that are generated spontaneously by noise and not by some input stimulus). Given this biological background, the objective of this work is to emulate the information on transmission of myelinated axons by the introduction of dependent uncorrelated noise sources.

3. FitzHugh-Nagumo model

The FitzHugh-Nagumo model has been widely used to emulate conductance-based neuron models as a simplification of the Hodgkin-Huxley model. As mentioned earlier, we employ an electrical circuit of the FitzHugh-Nagumo model operating in the excitable mode. We embed a current noise source in parallel with a tunnel diode (Fig. 2) in order to emulate the noise effect during spike transmission.

We serially connect circuits through resistors (bidirectional coupling) in order to emulate the serially connected nodes at the axon (Fig. 3) and the dynamics of the 1-D

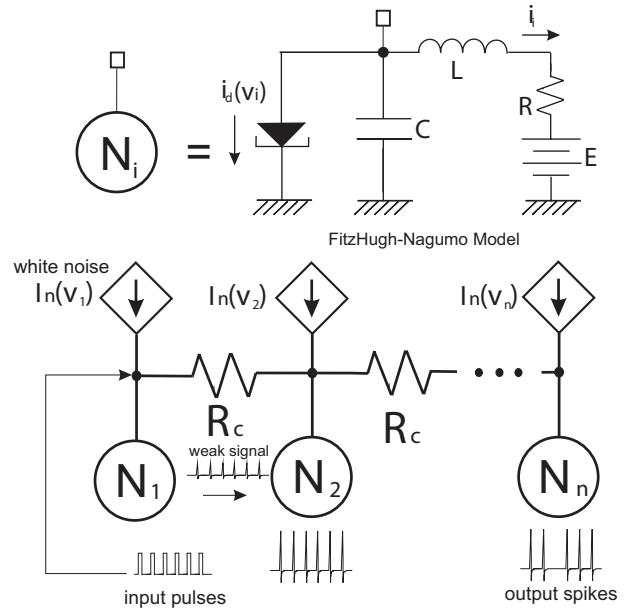

Figure 3: Block diagram of serially-connected circuits with noise-assisted spike propagation

excitable medium (our virtual axon), where the excitable circuits are locally coupled, have been represented by the following continuous forms.

$$C \frac{\partial v(x)}{\partial t} = g \frac{\partial^2 v(x)}{\partial x^2} + i(x) - i_d[v(x)] + I_n[v(x)] \quad (1)$$

$$L \frac{\partial i(x)}{\partial t} = E - R \cdot i(x) - v(x) \quad (2)$$

where x denotes the space; $i_d(\cdot)$, the I-V characteristics of the tunnel diode; $v(x)$, the membrane potential at x ; E , the resting potential; and $I_n[v(x)]$, the $v(x)$ -dependent dynamic noise current where the noise current is generated only when $v > E$. The characteristics of $I_n(\cdot)$ is crucial for successive spike transmission; i.e., if noises are generated independent of v , excitable circuits that should not be depolarized (receiving no input) may be depolarized by the noise, whereas if noises are generated only when $v > E$, the circuits may be depolarized only when inputs (external stimuli or firing of the neighbors) are given, even if the input is below the threshold of depolarization.

4. Simulations and Results

SPICE (Simulation Program with Integrated Circuit Emphasis) simulations were conducted for this excitable system, having the following parameters: tunnel diode NEC 1S1760, $C = 0.1$ nF, $R = 0.2$ Ω , $L = 10$ μ H, and $E = 50$ mV. Nine excitable circuits ($i = 1 \sim 9$) were locally connected by resistors R_c ($\sim g$), and the first circuit on the boundary was stimulated by an external current pulse (amplitude: 0.5 mA, width: 1 μ s). When each resistor R_c is 1

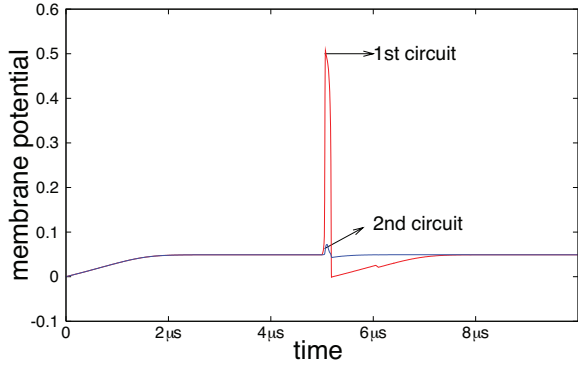

(a)

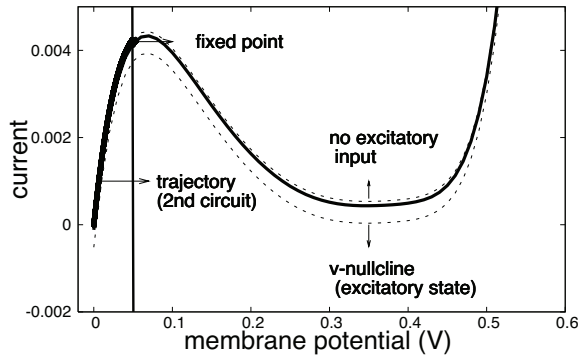

(b)

Figure 4: (a) membrane potential at 1st and 2nd circuit without noise assistance, (b) phase portrait.

$k\Omega$, successive spike transmission was observed (from the first to the ninth circuit) without noise assistance ($\sigma = 0$), whereas spike transmission was randomly terminated when R_c was $1.5 k\Omega$. As it can be observed in Fig. 4(a), a postsynaptic potential is not generated, only a small perturbation in the second circuit is observed. This phenomenon occurs as a result of the reduction in the input spike, owing to the supra-threshold value of the internodal resistances, and therefore, it is not possible to excite the subsequent remaining stages, without any response. The corresponding phase portrait is shown in Fig. 4(b), where the solid line represents the trajectory of the system response of the second circuit, converging to the fixed point (resting state), without any excitation trajectory. These figures clearly show that the spike transmission is stopped in the presence of supra-threshold values for internodal resistors.

On the other hand, when noise sources are introduced, spike transmission is successful. Fig. 5(a) shows spike propagation for the 3rd, 5th, 7th, and 9th circuit, showing that with the introduction of noise sources, spike propagation is successfully achieved. Fig. 5(b) shows the phase portrait with the corresponding trajectories.

A more general view of spike transmission is however necessary. Figure 6, shows the simulation results for spike propagation along circuits 1, 3, 5, and 9, connected through supra-threshold values for internodal resistors, where a cur-

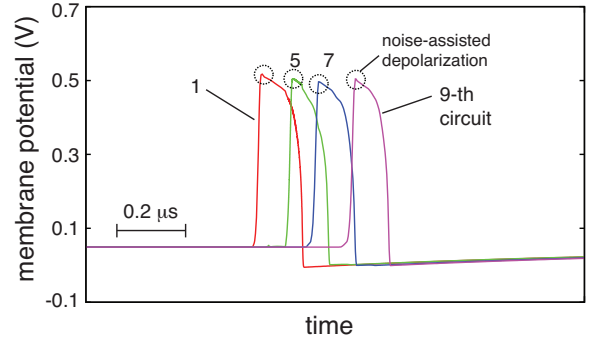

(a)

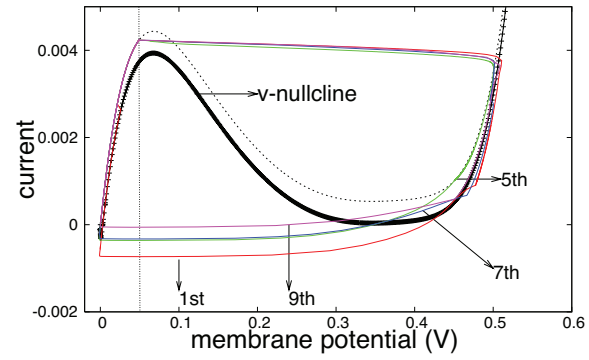

(b)

Figure 5: (a) membrane potential at 1st, 5th, 7th, and 9th circuit with noise assistance, (b) phase portrait.

rent pulse is applied as an excitatory input during $150 \mu s$. However, because of the stochastic nature of the noise sources, spike transmission is not successful in some cases; therefore, we define the spike transmission rate as the percentage of spikes transmitted to the last circuit.

On the other hand, it is necessary to explore how spike transmission is affected by the standard deviation of noise. Several simulations were run by using different values of standard deviation. Fig. 7 shows the transmission rate (percentage of transmitted spikes) for circuits 3, 5, 7, and 9. Several simulations were run using different values of standard deviation. Monte Carlo simulations were run for 100 iterations for 21 different values of standard deviation. The continuous lines in Fig. 7 represent the average between 10 Monte Carlo simulations (represented by different symbols for each circuit). As it has been observed, it is more probable to generate a spike in the subsequent circuits as the standard deviation of noise increases. In previous works [5], the amplitude of the noise input is independent of the membrane potential; in these cases, SR-like behavior could be observed; but in this particular case, noise is dependent on the membrane potential value, as the weak noise signal may not be able to assist input spike to excite the subsequent stages. However, as the amplitude of the noise signal increases, the probability of spike generation increases though there is a specific value at which, the spike trans-

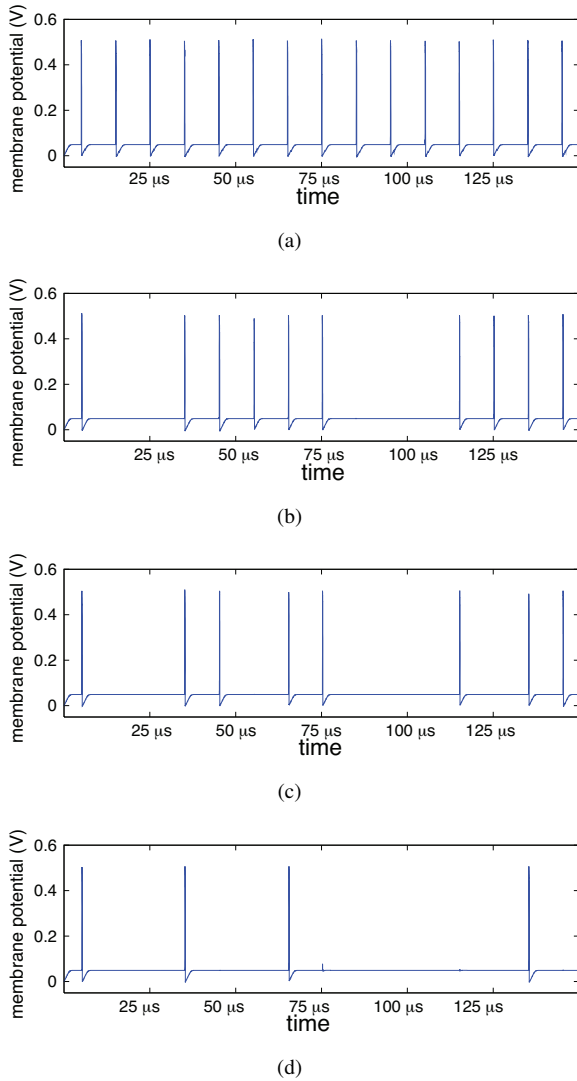

Figure 6: Transmission of spike trains assisted by noise for the 1st (a), 3rd (b), 5th (c), and 9th (d) circuit.

mission rate stops increasing (around 0.8mA) and remains constant. Nevertheless, even if SR-like behavior is not observed, the main advantage of the introduction of the dependent noise current source is that unwanted spikes are avoided.

5. Conclusions

We explored the effect of noisy signals on spike transmission in myelinated axons and thereby improved weak spike transmission in the serially-connected circuits based on stochastic the FitzHugh-Nagumo model. This sets the task to develop noise-assisted active transmission lines consisting of coarse-grained devices and materials as a future objective. The results of SPICE simulations showed that for weak stimuli, when noise was applied, it was more probable that a spike would be generated in the next stage.

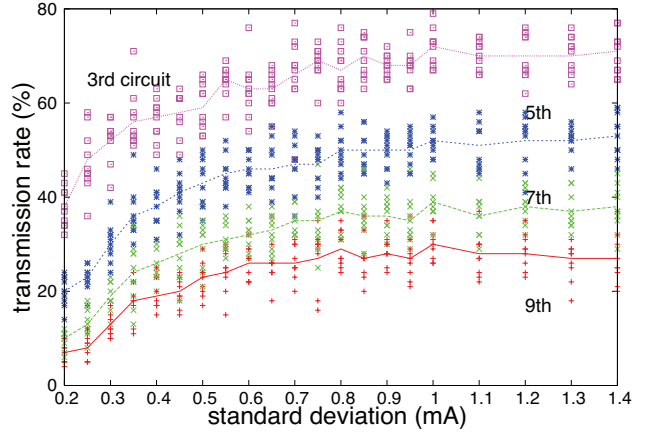

Figure 7: Percentage of successful spikes versus standard deviation of noise.

One key factor in successful spike transmission is the introduction of a membrane-potential-dependent current source as the noise input, in order to avoid unwanted spike generation, since the noise source is only activated when there are sub-threshold stimuli. Moreover, there is a critical value for noise amplitude where the spike transmission rate stops increasing and fluctuates around a certain value. Although SR-like behavior is not exhibited, spike transmission is improved considerably by noise assistance. We will further investigate how random values for internodal resistances (for both sub-threshold and supra-threshold case) affect the spike transmission rate.

References

- [1] Ochab-Marcinek A. *et al.*, "Noise-assisted spike propagation in myelinated neurons" *Phys. Rev. E*, 79, 011904, 2009.
- [2] L. Gammaitoni, *et al.*, "Stochastic Resonance" *Rev. Mod. Phys.* 70, 225, 1998.
- [3] Pei X, Wilkens LA., Moss F., "Light enhances hydrodynamic signaling in the multimodal caudal photoreceptor interneurons of the crayfish.", *J Neurophysiol.*, Vol. 76, 1996.
- [4] Collins, J. J., Imhoff, T. T. and Grigg P. J. "Noise-enhanced tactile sensation", *Nature*, Vol. 383, pp. 770, 1996.
- [5] Minato Kawaguchi, *et al.*, "Stochastic Resonance Can Enhance Information Transmission in Neural Networks" *IEEE Trans Biomed Eng* 58:1950-8, 2011.
- [6] Peter N. Steinmetz , Amit Manwani , Christof Koch , Michael London and Idan Segev, "Subthreshold Voltage Noise Due to Channel Fluctuations in Active Neuronal Membranes ", *J. Comput. Neurosci.*, Vol. 9, pp. 133-148, 1999.