

Acoustic Effect Using Chaos Controlled by an External Signal

Hironori Kumeno[†]

[†]Department of Mechanical engineering, National institute of technology, Niihama college
7-1 Yagumo, Niihama, Ehime 792-8580, Japan

Abstract—In this study, a system which apply chaotic fluctuation to improvement of sounds is proposed. Fluctuation of chaos has possibility to append natural nuance to electric sounds and to generate good electric sounds imitate sounds of nature. To implement the system, bifurcations of chaos circuit generating chaotic fluctuation are investigated. Additionally, in circuit experimentation, chaotically fluctuated output sounds are observed when sound signals are input to the system.

1. Introduction

One of the characteristics of chaos is non-periodic fluctuation. The fluctuation influence human mind in a positive way like $1/f$ fluctuation. Features deciding nuance of the sound is the fluctuation. Applying the chaotic fluctuation will make good sounds influencing human mind. On the other hand, Common electric sounds made of combinations of canned audio sources and periodic oscillators. Therefore, the electric sounds can not represent rich natural sounds. Applying the chaotic fluctuation permit the electric sounds to express nature nuance. Studies of chaos are widely carried out[1]-[7]. However, there are few study about applying the chaotic fluctuation to electrical instrument on analog electronic circuit. We aim to develop electrical instrument applying the chaotic fluctuation on analog electronic circuits.

In this study, a system which apply chaotic fluctuation to improvement of sounds is proposed. To implement the system, bifurcations of chaos circuit generating chaotic fluctuation are investigated. In circuit experimentation, chaotically fluctuated sounds output from the system are confirmed.

2. Chaotically Fluctuating System

The chaotically fluctuating system is an analog electronic circuit which fluctuate an input sound signal in accordance with chaotic signals and then output. The framework of the system is shown in Fig. 1. The system is constructed of an amplitude-modulation circuit and an chaos circuit controlled by an external signal. The chaos circuit generates voltage signals of chaotic waves which are used as modulation signals. The modulation signals chaotically fluctuate the amplitudes of the input sound signals. Then, the system output the sounds which have chaotic characteristics. There are several amplitude-modulation circuits, the

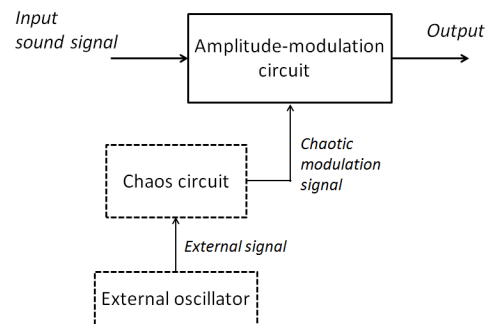

Figure 1: Framework of the system which append chaotic fluctuation to sound signals.

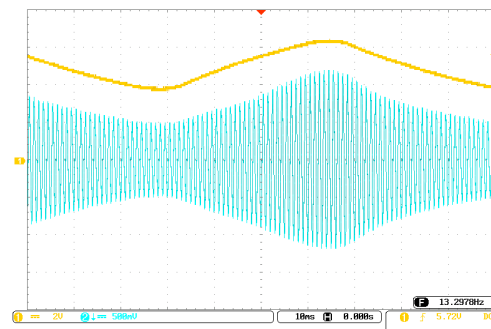

Figure 2: A modulating wave and an output signal when a sinusoidal wave is input. The upper line shows the modulating wave, and the lower line shows output signal.

circuit shown in Fig. 3 is used as the amplitude-modulation circuits in this study. In the figure, the operational amplifier constructs the inverting amplifier whose amplification degree is determined by resistors and a JFET. The resistance value of JFET between D terminal and S terminal is controlled by the voltage between G terminal and S terminal. The amplification degree of the amplifier is controlled by the voltage signal input to G terminal of the JFET. As an example, a modulation signal and an output sound signal are shown in Fig. 2 when a voltage signal of a triangle wave is input to G terminal of the JFET and a sinusoidal wave is input to the system as a sound signal. The amplitude of the sinusoidal signal is modulated in accordance with the

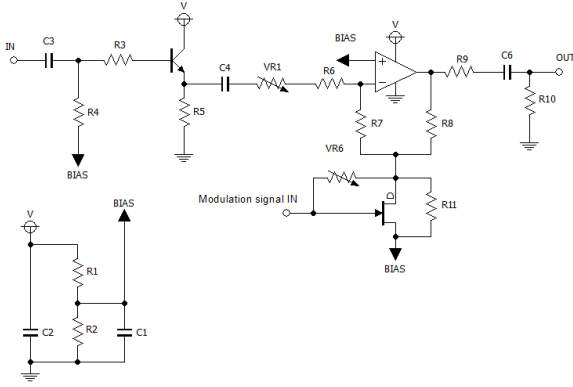

Figure 3: Amplitude-modulation circuit.

triangle wave. In this study, chaotic signals are used for modulation signals which control the amplification degree. The chaos circuit in Fig 1 is explained in the next section.

3. Chaos Circuit

Figure 4 shows a chaos circuit used in this study. The chaos circuit is constructed of capacitors, resistors, operational amplifiers and an external signal. Rectangular wave is used for the external signal in this study. The comparators compare the voltage of the rectangular wave with the voltages of the capacitors and output positive or negative voltage. Since the chaos circuit is simple and does not include inductors, noise is relatively low. Figure 5 shows the rectangular wave. V_S and T are respectively the amplitude and the period of the rectangular wave. The frequency of the rectangular wave termed as f is obtained from $1/T$. The circuit equations of the chaos circuit are described as follows;

$$v_1 = \begin{cases} (V_1 + E)e^{\frac{-1}{RC}t} - E & (V_2 \geq V_S) \\ (V_1 - E)e^{\frac{-1}{RC}t} + E & (V_2 < V_S) \end{cases} \quad (1)$$

$$v_2 = \begin{cases} (V_2 - E)e^{\frac{-1}{RC}t} + E & (V_1 \geq V_S) \\ (V_2 + E)e^{\frac{-1}{RC}t} - E & (V_1 < V_S) \end{cases}$$

where E is the output voltage of the comparators, namely the DC supply voltage of the operational amplifiers. Figure 6 shows an example of an attractor and waveform of chaos observed from the chaos circuit. The waveform is resembles a triangle wave. This form is convenient for modulation signal, because triangle wave is used as modulation signal in general electronic instruments. The chaos signal have non-periodic chaotic characteristics and pseudo triangle waveform.

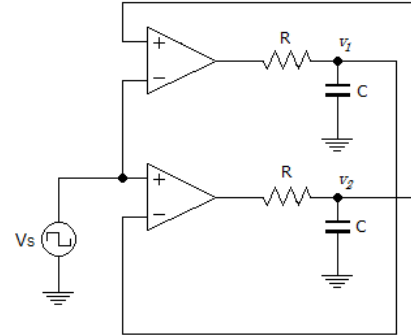

Figure 4: Chaos circuit.

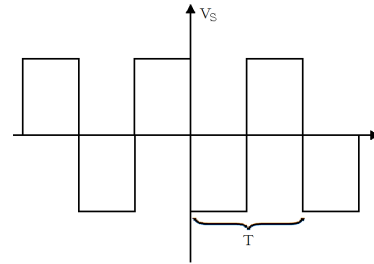

Figure 5: Rectangular wave used for the external signal.

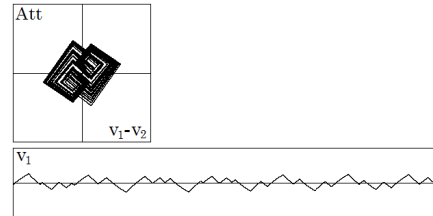

Figure 6: Attractor and waveform of chaos.

4. Chaotic Modulation Signal

The chaotic signals are used to fluctuate input sound signal in order to append chaotic effects. Therefore, it is better that the frequency of the chaotic wave is tens of hertz. Bifurcation of the chaos circuit is investigated in order to achieve chaotic waves whose frequencies are tens of hertz. The frequencies of the chaotic waves are varied widely by discharging rates of the capacitors and frequencies of the external signal which is the rectangular wave in this study. The resistors and the capacitors in the chaos circuit is selected from E6 series. On that basis, chaotic waves are generated by coordinate the amplitude and the frequency of the rectangular wave. Figure 7 shows a bifurcation diagram when parameters are set as $R = 470\Omega$, $C = 100\mu F$, $E = 12V$ and $V_S = 10V$. Figures 8-10 show attractors, Poincare maps, waveforms and rectangular waves

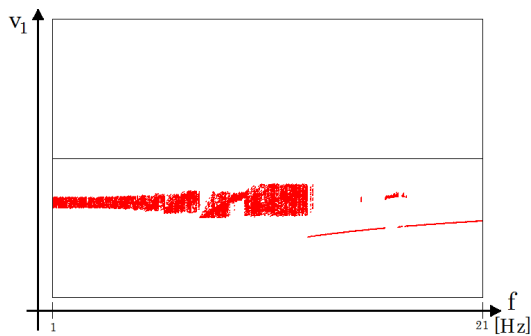

Figure 7: Bifurcation diagram for $V_S = 1.0V$.

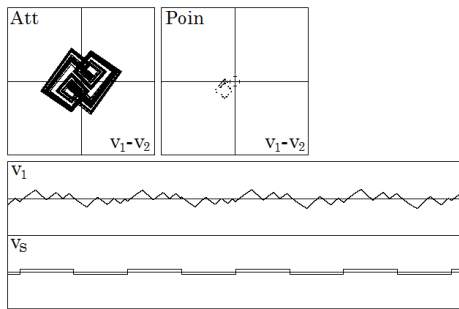

Figure 8: Attractor, poincare map, waveform and rectangular wave for $f = 7Hz$.

related to the Fig. 7. In the figures, it is confirmed that chaos are generated in widely parameter space. Figures 11 and 12 show bifurcation diagrams when V_S are set as 0.8V and 1.2V. Similar bifurcation diagrams are observed although parameter regions where chaos are generated are varied. From these observations, if elements include errors, chaotic waves can be generated by adjust V_S . V_S is easily adjusted by mount a variable resistor between the rectangular wave oscillator and the chaos circuit and divide the voltage of V_S .

5. Circuit Implementation and Chaotically Modulated Sound

Figure 13 shows circuit implementation of the system which append chaotic fluctuations to input sound signals. When several signals are input to the system, chaotically modulated output signals are observed. In order to clarify changes of input-output waveforms, periodic voltage signals are input to the system in stead of sound signals. Figure 14 shows the chaotic modulating signal and an output when a sinusoidal wave with a frequency of 100Hz is input. It is confirmed that the amplitude of the output is varied in accordance with the modulating signal. From Fig. 14(b), it is also confirmed that the sinusoidal wave of the output is not distorted. When the system is connected to a speaker,

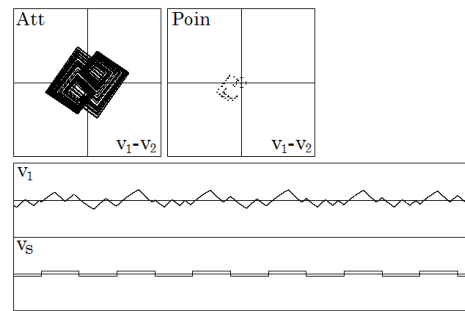

Figure 9: Attractor, poincare map, waveform and rectangular wave for $f = 10Hz$.

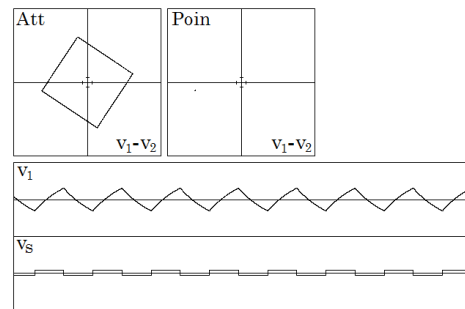

Figure 10: Attractor, poincare map, waveform and rectangular wave for $f = 13Hz$.

and sound signals are input, chaotically fluctuated sounds are observed. These fluctuations are non-periodic. By effectively using these fluctuations, natural vibrancies are append to flat electrical sounds.

6. Conclusions

In this study, the system which apply chaotic fluctuation to improvement of sounds was proposed. The chaos circuit was used to generate the chaotic modulation signal of the system. To implement the system, bifurcations of chaos circuit generating chaotic fluctuation were investigated. Chaotic signals could be generated by adjust the external signal. In circuit experimentation, input-output sound signals of the system were investigated. Chaotically fluctuated sounds output from the system were confirmed.

References

- [1] Mayer-Kress, G. and Choi, I. and Weber, N and Bargar, R. and Hübler, A. "Musical Signals from Chua's Circuit." IEEE Transactions on Circuits and Systems-II: Analog and Digital Signal Processing, vol. 40, No.10, pp. 688-695, 1993.
- [2] Rodet, X. "Models of Musical Instruments from

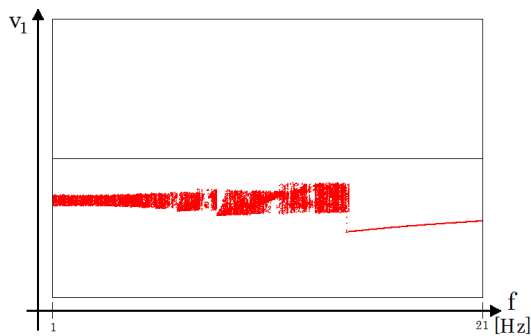

Figure 11: Bifurcation diagram for $V_S = 0.8V$.

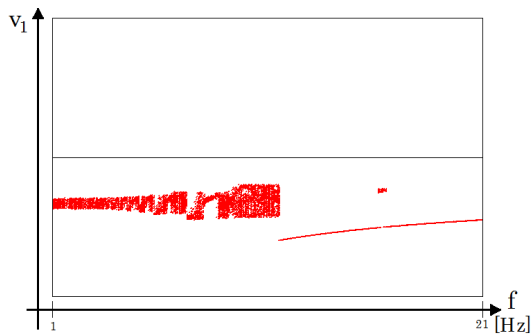
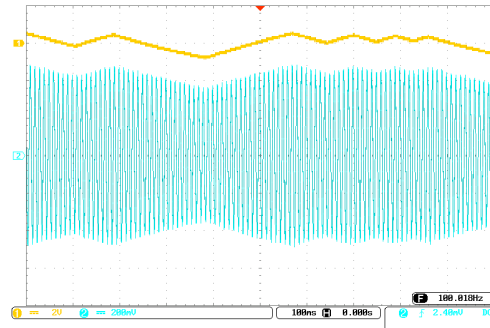
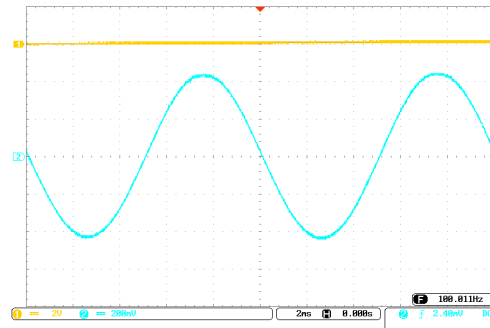

Figure 12: Bifurcation diagram for $V_S = 1.2V$.



(a)



(b)

Figure 14: A modulating chaotic wave and an output sound signal when a 100Hz sinusoidal wave is input. The upper line shows the modulating chaotic wave, and the lower line shows output sound signal. (b) is enlargement of (a).

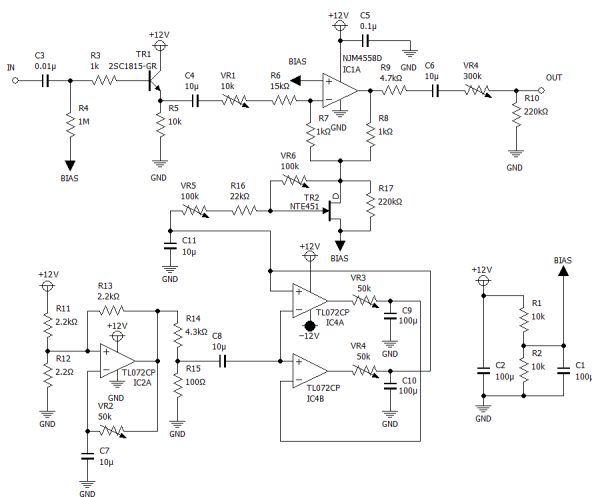

Figure 13: Circuit implementation of the system that append chaotic fluctuation.

Chua's Circuit with Time Delay." IEEE Transactions on Circuits and Systems-II: Analog and Digital Signal Processing, vol. 40, No.10, pp. 696-701, 1993.

[3] Abramson, G. and Kenkre, V. M. and Bishop, A. R., "Analytic Solutions for Nonlinear Waves in Coupled Reacting Systems." Physica A: Statist. Mech. Appl. 636 -

vol. 305, pp. 427-436, 2002.

[4] Lind, P. G. and Titz, S. and Kuhlbrodt, T. and Cortereal, J. A. M. and Kurths, J. and Gallas, J. A. C. and Feudel, U., "Coupled Bistable Maps: A Tool to Study Convection Parameterization in Ocean Models." Int. J. Bifurcation and Chaos, vol. 14, num. 3, pp. 999-1015, 2004.

[5] Freeman, W. J., "A Neurobiological Theory of Meaning in Perception. Part I: Information and Meaning in Nonconvergent and Nonlocal Brain Dynamics." Int. J. Bifurcation and Chaos, vol. 13, num. 9, pp. 2493-2511, 2003.

[6] Cosp, J. and Madrenas, J. and Alarcon, E. and Vidal, E. and Villar, G., "Synchronization of nonlinear electronic oscillators for neural computation." IEEE Trans. Neural Networks, vol. 15, pp. 1315-1327, 2004.

[7] Zhang, W. and Song, C. and Ye, M., "Further Studies on Nonlinear Oscillations and Chaos of a Symmetric Cross-Ply Laminated Thin Plate under Parametric Excitation," Int. J. Bifurcation and Chaos, vol. 16, num. 2, pp. 325-347, 2006.