

## Quinary Coded Decimal Conversion Techniques

Ali Massoud Haidar & Hassan Amin Osseily\*  
Elias Nassar\*\*, Hiroyuki Shirahama\*\*\*

\*Faculty of Engineering, Beirut Arab University, Beirut - Lebanon

\*\* Faculty of Engineering, Notre Dame University, Zouk - Lebanon

\*\*\*Faculty of Education, Matsuyama University, Japan

Email : ari@bau.edu.lb , sasoha@yahoo.com , enassar@ndu.edu.lb , jyuichiro@yahoo.co.jp

**Abstract-** The aim of this paper is to introduce new models, algorithms and circuits of quinary to quinary coded decimal (QCD) conversion. In classical binary logic [1,2], the conversion from binary to binary coded decimal could be done easily while in higher valued logic [3,4,5] the matter of conversion will be much different and done in a much difficult way. Many methods of conversion from quinary to quinary coded decimal were considered such as the counters comparison, table look up and addition technique of the quinary number 30 (15 in decimal). These methods are common for all multi-valued radices [6]. Here we will develop the algorithm and the circuit of addition technique using adder and subtraction units. Then we will introduce a new algorithm called "division by 2" technique and we will develop its circuit using  $\delta$ -gate [7,8]. Finally, we will make a brief comparison between these two methods in terms of cost and performance.

### 1. Introduction

The QCD numbers are useful wherever decimal information is transferred into or out of any quinary computerized unit. In quinary code, each digit is assigned as a weight of  $5^0$ , and  $5^1$  while the quinary coded decimal is a code where each digit of the decimal system (0 to 9) is represented by 2 digits of quinary code.

The following table shows the QCD numbers:

**Table 1:** Table of QCD numbers

Decimal	$5^1$	$5^0$
0	0	0
1	0	1
2	0	2
3	0	3
4	0	4
5	1	0
6	1	1
7	1	2
8	1	3
9	1	4

The other cases 20 up to 44 are not acceptable in QCD code and we say that these numbers are incorrect and an error is generated.

The advantage of this code is the simplicity to transfer from and to decimal numbers where we need only to remember the quinary numbers from 0 to 9. The disadvantage of this code occurs when performing the arithmetic operations. The result of addition, for example, for two QCD numbers could be incorrect and we need to use a predetermined technique to obtain a true result.

### 2. Quinary to Quinary Coded Decimal Conversion Using the "Addition of 30" Technique

#### 2.1. Arithmetic Addition in QCD System

In the quinary system, the addition operation can be simply performed as shown in the following examples.

Decimal	Quinary
12	22
+10	+20
22	42

But in QCD code , the addition operation becomes:

Decimal	1 <sup>st</sup> . quible	2 <sup>nd</sup> quible
12	01	02
+10	+01	+00
(22)	(02)	(02)
	2	2

The result of QCD code is correct 22.

A new case:

Decimal	QCD	
12	01	02
+9	+00	+14
(21)	(01	21)

The result here is incorrect because it contains a number (21) which does not belong to QCD code.

2.1.1. Lemma 1

When adding two decimal numbers consisting each of several digits, the result of addition in QCD code will be correct if and only if the sum of the digits having equal weights is equal or less than 9. For example:

Decimal	QCD
2	02
+3	+03
5	10

10 = (5)<sub>10</sub> is correct because (2+3) < 9.

2.1.2. Lemma 2

When adding two decimal numbers consisting each of several digits, the result of addition in QCD code will be incorrect if the sum of two digits having equal weights is greater than 9. For example:

Decimal	QCD
5	10
6	11
11	21

The result (21) is incorrect and does not belong to QCD code because the sum (5+6) is greater than 9.

2.1.2. Lemma 3

If the sums of each two digits of the two decimal numbers are greater than 9, In this case we add the quinary number 30 to each quible of the result to terminate the ring and to make the results belong to QCD set.

Consider the following example:

Decimal	QCD
55	10 10
87	13 12
142	(23 22)

23 and 22 do not belong to QCD set, we have to add 30 to 23 and 22 as follows:

23	22
+30	30
01	04 02

The result becomes correct.

2.2. Algorithm of Q/QCD Converter Using Addition Technique

To develop a conversion algorithm that can convert any quinary N to QCD, we will apply a loop of addition of the number 30 to the number N. To do that, we have to split the quinary set into intervals to know how many times we

should run the loop. If we take intervals consisting each of ten quinary numbers, here we shall add one time 30 to numbers between 10 ≤ N < 20 and twice to the numbers 20 ≤ N < 30 and three times to the numbers 30 ≤ N < 40 and so on. In general:

$$n * 10 \leq N < (n+1) * 10 \text{ add } n * 30 \quad (1)$$

For example, the decimal number 45 = (140)<sub>Q</sub>, can be written as follows:

$$45 = 4 \times 10 + 5$$

So to convert it into QCD system, we have to repeat the addition of 30 to the quinary (140) four times. The result will be (04 10) which belongs to QCD and equals to the decimal 45.

2.3. Logic Circuit of Q/QCD Converter Using Addition Technique

Figure 1 shows a converter block diagram that can convert a quinary number with 3 quits into a QCD code where the quinary number 344 (99 in decimal) is the maximum quinary value that can be converted. The equivalent QCD number in this case will have 4 digits (or 2 quibles).

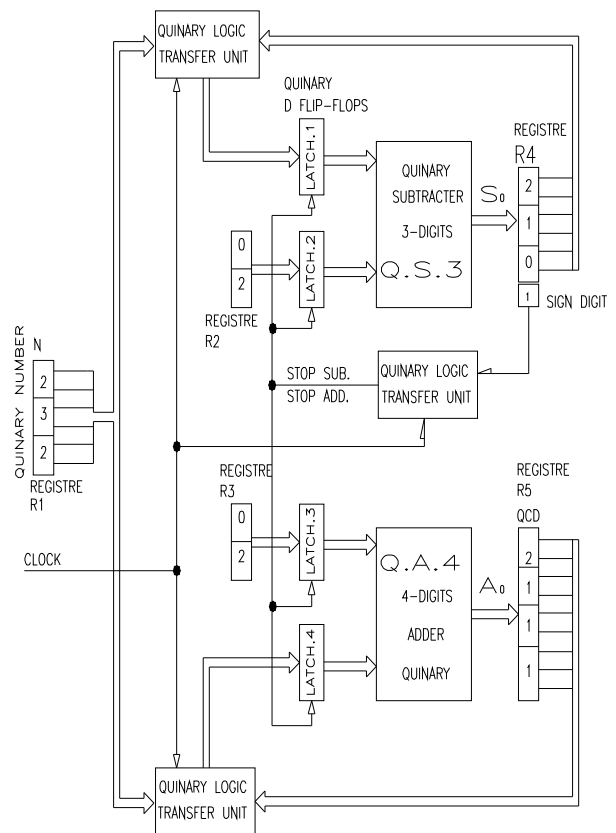

Figure 1: Q to QCD Using Addition Technique

For the first clock cycle, the quinary number will be added to 30 at the adder and will be subtracted of 20 at the

subtractor. For the second cycle, the transfer units transfer to a feedback state to repeat the addition and subtraction operations. This will continue for many clock cycle until we get a negative result at subtracter output. In this case, the quinary logic transfer unit will stop the addition and subtraction operations by taking a command from the sign digit of the subtracter. The QCD number is obtained at the output of the adder.

### 3. Quinary to Quinary Coded Decimal Converter Using the Method of "Division by 2".

We have noted from the previous method that it contains many addition and subtraction operations even for small quinary numbers and this will make the elements cost quite high and the performance quite low. For that, we will introduce a new technique of conversion and we will develop the corresponding logic circuit by using delta gates [7,8] as basic switching elements.

#### 3.1. Algorithm of Quinary to Quinary Coded Decimal Converter Using "Division by 2" Technique

Let CBA be a quinary number that we want to convert into a quinary coded decimal number with the form "dc ba" where A,B,C,a,b,c,d belong to the quinary numbers set {0,1,2,3,4}. To determine "ab cd" by using the method of division by 2, we have to apply the following equations:

$$a = A \quad (2)$$

$$b = 0 \text{ (if CB is an even number)} \quad (3)$$

$$b = 1 \text{ (if CB is an odd number)} \quad (4)$$

$$dc = (CB/2) \text{ (if BC is an even number)} \quad (5)$$

$$dc = (CB-1)/2 \text{ (if BC is an odd number)} \quad (6)$$

##### 3.1.1 Example 1

Let Q1 a quinary number Q1=231 (or is equal to 66 in decimal) and we want to convert it to QCD system. The result will be obtained directly from the equations (2,3,4,5,6) of a,b,c and d where A=1, B=3 and C=2:

- a=A=1
- b=1 because CB=23 is odd (13 in decimal)
- $dc = (CB-1)/2 = (23-1)/2 = 11$  then c=1, d=1

Then the QCD equivalent to the quinary number 231 is:  
QCD=dc ba = 11 11 (or 66 in decimal)

#### 3.2. Quinary $\delta$ Gate

The output of  $\delta$  gate [7,8] is defined as:

$$\delta(A,B;a;b) = \begin{cases} A & \text{if } a=b \\ B & \text{otherwise} \end{cases} \quad (7)$$

Where,

- A,B,a,b belong to the quinary set  $Q=\{0,1,2,3,4\}$

- a, b: control variables
- A, B: residue variables

The symbol of this logic gate is as follows:

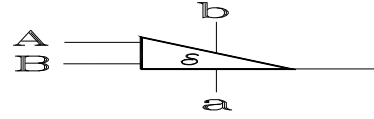

Figure 2: Symbol of  $\delta$  gate

based on the  $\delta$  gate, any quinary logic function of one input variable x can be represented by the equation (8) and be realized with four  $\delta$  gates as shown in Figure 3.

$$f(x) = \delta(\delta(f(i0), \delta(f(i1), \delta(f(i2), \delta(f(i3), f(i4); i3; x); i2; x); i1; x); i0; x) \quad (8)$$

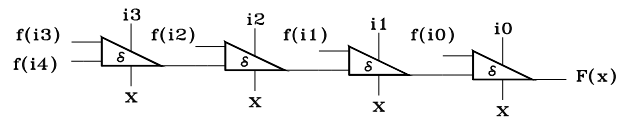

Figure 3: Network of  $f(x)$

#### 3.3. Quinary to Quinary Coded Decimal Converter Logic Circuit Using $\delta$ gate:

To construct the logic circuit of the Q to QCD converter which is based on the division by 2 algorithm, we have to return to the conversion truth table:

Table 2: Table of Q to QCD Conversion

Decimal	Quinary CBA	QCD dc ba
0	000	00 00
1	001	00 01
....	....	....
9	014	00 14
....	....	....
30	110	03 00
....	....	....
99	344	14 14

From this table, we note that:

- a=A
- b=0 if CB even
- b=1 if CB odd
- $cd = (CB/2)$  for CB even
- $cd = (CB-1)/2$  for CB odd.

The logic circuit that verifies these equations is shown in Figure 4 with a quinary input 333:

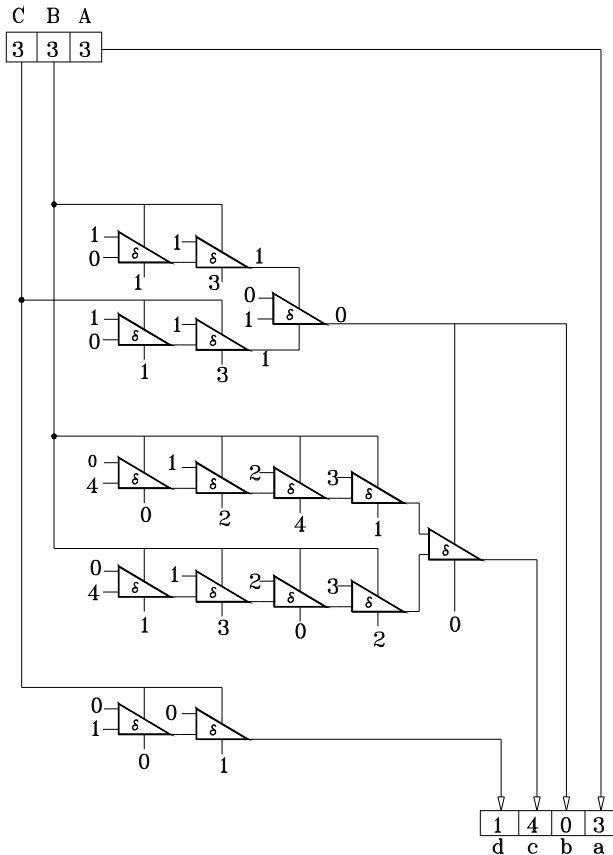

**Figure 4:** Q to QCD converter using  $\delta$  gate

The circuit consists of three main branches that are needed to determine  $b$ ,  $c$  and  $d$  while  $a$  is connected directly to  $A$ .

- The first circuit aims to determine if  $CB$  is even or odd by giving at its output "b" 0 for even numbers and one for the odd ones.
- The second circuit's role is to represent the function of "c" that can be done by several  $\delta$  gates as shown.
- The third circuit is designed to give at its output "d" 0 if  $C=0$  and 1 if  $C=2,3$

From the output of these circuits, we will find that the converted number in QCD is 14 03 or 93 in decimal, remembering that the maximum value of "C" is 3 since the maximum number can be converted by this circuit is 344. For larger numbers, we could use this circuit as the main element to build other converters with higher capacities.

#### 4. Applications

Quinary logic is one of the the multi-valued logic MVL that could be the solution for interconnection complexity and could be an approach to enlarge the memories capacity with fewer address lines than in binary logic. At the moment, we can not replace totally the binary by any

other system due to the large use of the classical system in all old and even in recent machines and computers all over the world. But we could use the new system (quinary system) in the independent and individual systems such as digital cameras, logic controllers or any other computerised or memorized system that we do not need to connect them to the old systems. QCD is here intended to display as decimals all quinary information in order to be understood by users who need only to read results from these quinary logic or arithmetic units.

#### 5. Conclusion

This paper presented the development of a new technique concerning the conversion through quinary system to quinary coded decimal system using division by 2 algorithm. The advantages of this technique are the design simplicity and the high performance compared with all other methods. This technique can be generalized for any length of quinary numbers.

The minimum number of  $\delta$ -gates that is required to build a converter with addition technique is more than one hundred and it requires 10 clock cycles at least to perform a number such as 344, while the number of  $\delta$ -gates required for the division technique is only 16 and any number (up to 344) can be converted with one cycle. This technique is therefore the best in cost and in performance.

#### References

- [1] Morris Mano and Charles R. kime "Logic and Computer Design Fundamentals" second edition, PP.3-24 Prentice-Hall publishing New Jersey, 2001.
- [2] Albert Paul Malvino, "Digital Computer Electronics" second edition, Tata McGraw-Hill publishing Company Limited, NEW DELHI, 1994.
- [3] Goerge Epstein, "Multiple-Valued Logic Design: an introduction" . PP.12-51 University of North Carolina, computer science department, USA. 1993.
- [4] Goerge Epstein, "The Development of Multiple-Valued Logic as Related to Computer Science" . Computer, Vol. C-9, PP.20-33, Indiana University, USA. September 1974.
- [5] Sasoa, T., "Multiple-Valued Decomposition of Generalized Boolean Functions and the Complexity of Programmable Logic Arraya", IEEE Trans. On Comp., Vol. C-30 No. 9, pp. 635-643, September 1981.
- [6] H. A. Osseily "Ternary Arithmetic and Logic: Operations and Circuits", Beirut Arab University, Lebanon, Faculty of Engineering, Master thesis, PP.75-83, 2001.
- [7] A. M. Haider, "Analysis and Design of Multiple valued logic systems" Japan 1995 SAITAMA UNIVERSITY (PHD thesis).
- [8] A. M. Haider, C.Zukeran. C.Afuso and T.Yamashiro."Design of a Quaternary  $\delta$ -gate and its characteristics" IEICE. conference.pp.1-114. 1991.