

STATISTICAL CHARACTERISTICS OF SCATTERING OF SUBSURFACE RADAR PULSES BY BURIED OBJECTS IN RANDOM MEDIA

Koichi TAKAHASHI and Yasumitsu MIYAZAKI
Department of Information and Computer Sciences,
Toyohashi University of Technology,
Tempaku-cho, Toyohashi, 441-8580, JAPAN.
E-mail miyazaki@emlab.tutics.tut.ac.jp

1. Introduction

Recently, subsurface radar has been paid worldwide attention for detection of buried objects, such as gas and water pipes, archaeological prospects and mines. For these applications in the underground media, subsurface radar of very high resolution is required. However, since the underground media is inhomogeneous, many undesirable scattered waves are generated and the received signals will have random fluctuations. Therefore, the separation of the target signal from the undesired signals is very important. Moreover, when the target has similar permittivity to that of underground, as in the case of plastic materials, the intensities of scattered waves from the target are very weak for the target detection. In this study, we considered the statistical characteristics of the electromagnetic wave scattering in random media, and the knowledge acquired will be useful to achieve solving the above-mentioned problems. We considered a simulation model in which the target is an air gap buried in random media, and transmitted electromagnetic pulse is scattered from the target as well as from many obstacles buried in the random media. Transient response characteristics of electromagnetic pulse by buried objects are numerically simulated using 3-dimensional FDTD method. The properties of random media are shown statistically, using autocorrelation function and correlation length. The received signals are evaluated by correlation function and standard deviations.

2. 3-dimensional FDTD simulation for Subsurface Radar

FDTD method can effectively be applied for the analysis of complex materials, such as random media. Using FDTD simulations, we analyzed the received signal of subsurface radar from the target object buried in the random media. The simulation model of subsurface radar system is shown in Fig. 1. The geometry of the analysis region is defined as $L_x = L_y = 1.28\text{m}$, $L_z = 1.5\text{m}$, $L_g = 1.28\text{m}$ and $L_a = 0.22\text{m}$. For the material constants of soil, permittivity of 3.0, conductivity of 0.02 S/m and the permeability μ_0 are assumed. An air gap, which is the target, has a dimension of $0.4 \times 0.4 \times 0.2\text{m}$ is placed at 0.5m depth. Bow-tie antenna is used as the subsurface radar antenna for the electromagnetic pulse transmission and reception. The transmitting antenna and the receiving antenna are placed at 4cm distance from each other and both are placed at a distance of 2cm above the ground surface. The structure of bow-tie antenna is shown in Fig. 2. The incident voltage is a Gaussian pulse with a pulse width of 0.5 nsec. FDTD equations for calculating electric fields at a time step n are,

$$E_y^n(i, j+1/2, k) = \frac{1 - \frac{\sigma(i, j+1/2, k)\Delta t}{2\varepsilon(i, j+1/2, k)}}{1 + \frac{\sigma(i, j+1/2, k)\Delta t}{2\varepsilon(i, j+1/2, k)}} E_y^{n-1}(i, j+1/2, k) + \frac{1 - \frac{\Delta t}{2\varepsilon(i, j+1/2, k)\Delta s}}{1 + \frac{\sigma(i, j+1/2, k)\Delta t}{2\varepsilon(i, j+1/2, k)}} \left\{ H_x^{n-1/2}(i, j+1/2, k+1/2) - H_x^{n-1/2}(i, j+1/2, k-1/2) - H_z^{n-1/2}(i+1/2, j+1/2, k) + H_z^{n-1/2}(i-1/2, j+1/2, k) \right\} \quad (2)$$

where, Δs is cell size, Δt is time step. Cell size is 0.01m defined as 1/15 times the pulse length, and time step is 0.015 n sec determined by Courant criterion. The electric fields at the boundaries of analysis region are calculated by Mur's second order absorbing boundary

conditions. The electric field at antenna feed source are calculated using delta gap model,

$$E_y^n(i_s, j_s + 1/2, k_s) = -\frac{V_t^n}{\Delta s} \quad (3)$$

The received voltage is calculated by

$$V_r^n = E_y^n(i_r, j_r + 1/2, k_r) \Delta s \quad (4)$$

where, i_s, j_s, k_s and i_r, j_r, k_r correspond to the coordinates of feed point and receiving point respectively.

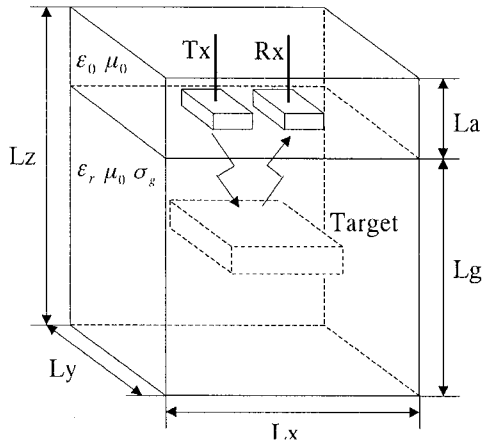

Fig. 1 3-dimensional simulation model of Subsurface radar system.

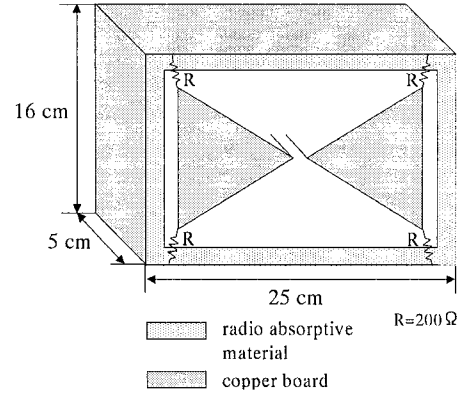

Fig. 2 The structure of bow-tie antenna.

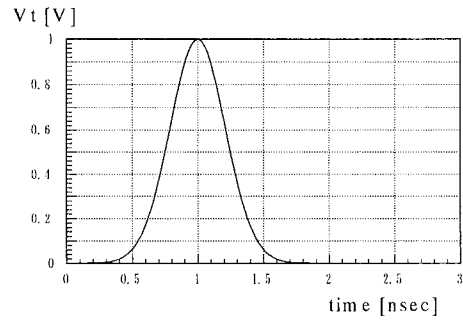

Fig. 3 The incident voltage pulse.

3. Statistical analysis of electromagnetic scattering in random media

The received signals obtained by FDTD simulation contains scattered waves from the target, which are affected by the random media. The properties of random media are characterized by correlation length and mean value of the permittivity. The normalized autocorrelation function, correlation length and average permittivity are defined by

$$R_{gn}(\mathbf{r}) = \frac{\iiint \varepsilon_r(\mathbf{r}') \varepsilon_r(\mathbf{r} + \mathbf{r}') d\mathbf{r}'^3}{\iiint \varepsilon_r^2(\mathbf{r}') d\mathbf{r}'^3} \quad (5) \quad l_z = \{|\mathbf{r}'| | R_{gn}(\mathbf{r}) \leq 1/e\} \quad (6) \quad \mu_{\Delta\varepsilon} = \frac{1}{V} \iiint \Delta\varepsilon(\mathbf{r}) d\mathbf{r}^3 \quad (7)$$

where, $\Delta\varepsilon(\mathbf{r}) = \varepsilon_r(\mathbf{r}) - \varepsilon_{rg}$, ε_r is the relative dielectric constant of the soil, equals to 3.0. With respect to the received signals, the squared mean deviation, the mean value of received signal and the correlation coefficient are defined as follows,

$$\mu_{PP} = \frac{1}{T} \int_0^T \Delta V_{PP}(t) dt \quad (8) \quad \sigma_{PP} = \frac{1}{T} \int_0^T [\Delta V_{PP}(t)]^2 dt \quad (9) \quad R_{PP} = \frac{C(Vr_{PP}, Vn_{PP})}{\sigma_{r_{PP}} \cdot \sigma_{n_{PP}}} \quad (10)$$

where $\Delta V_{PP}(t) = Vr_{PP}(t) - Vn_{PP}(t)$, $Vr_{PP}(t)$ and $Vn_{PP}(t)$ are the received signals by PP polarization in random media and homogeneous media, respectively.

4. Simulation Results and Conclusions

Fig. 4~6 show the numerical results of various random media. Case 1 is specified by $l_g = 0.04$ m and $\mu_{\Delta\varepsilon} = 0.06$, Case 2 by $l_g = 0.10$ m and $\mu_{\Delta\varepsilon} = 0.20$, and Case 3 by $l_g = 0.20$ m and $\mu_{\Delta\varepsilon} = 1.90$. The first target signal is received at the time of 7.8 ns. Using the definition given by equations (8)~(10), the effects of electromagnetic scattering by random media are evaluated statistically as shown in Table 1. Although the media in Case 1 has very short correlation length,

and the media has small average permittivity, the distortion of effects of random media are negligible. On the other hand, the media of Case 3 has large average permittivity and correlation length. The standard deviation σ_{VV} in this case becomes the largest, the effects of randomness also become the largest and shows that reflection intensity from the underground is very strong. The correlation coefficient R_{VV} in Table 1 shows that the received signal from the media in Case 2 is the most affected of the three cases. The intensity of received signal by the crosspolarized antenna is small, and is about 0.1 times the received signal obtained by the copolarized antenna. Extensive simulations of various random media are required for the discussion of the precise nature of these statistical parameters.

References

[1] Y. Miyazaki, J. Sonoda and Y. Jyonori, Trans. IEE Japan, vol. 117-C, no. 1, pp.35-41, 1997.
 [2] K. Takahashi and Y. Miyazaki, Trans. IEE Japan, vol. 118-C, no. 1, pp.93-98, 1998.
 [3] Y. Yamamoto, H. Ozo and Y. Miyazaki, Trans. IEE Japan, vol. 119-C, no. 1, pp.91-96, 1999.
 [4] Y. Nishioka, O. Maeshima, T. Uno and S. Adachi, IEEE Trans. Antennas Propag., vol. 47, no. 6, 1999.
 [5] J. M. Bourgeois and G. S. Smith, IEEE Trans. Geosci. Remote Sensing, vol. 34, no.1, 1996..

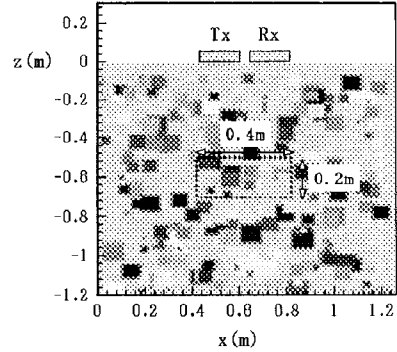

(a) Random medium $\epsilon_r(x, 0.64, z)$

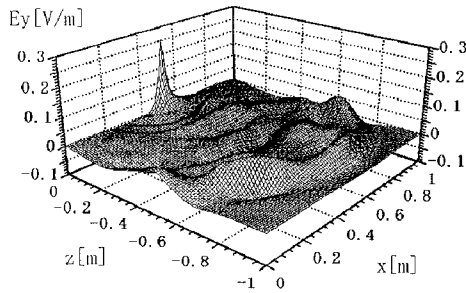

(b) Electric field on $y=0.64m$ at 6ns

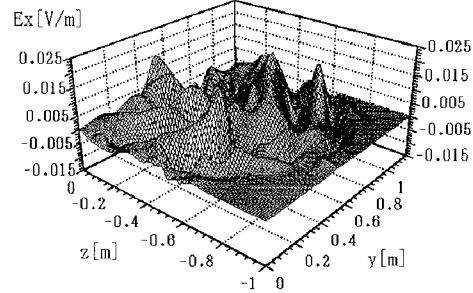

(d) Electric field on $x=0.64m$ at 6ns

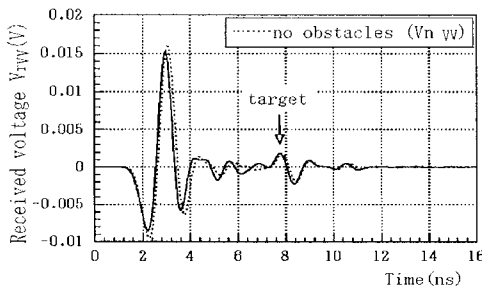

(c) Received signal at copolarization

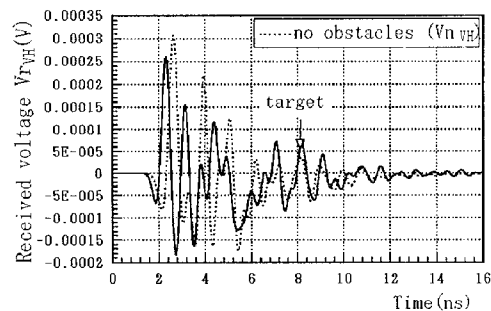

(e) Received signal at crosspolarization

Fig. 4 Results of FDTD simulation in Case 1 ($l_g = 0.04 m$, $\mu_{\Delta\epsilon} = 0.06$)

Table 1. Results of statistical analysis of electromagnetic wave scattering

	$\mu_{VV} \times 10^6$	$\sigma_{VV} \times 10^{-3}$	R_{VV}	$\mu_{VH} \times 10^6$	$\sigma_{VH} \times 10^{-3}$	R_{VH}
Case 1	-4.41	1.32	0.82	-27.7	3.39	-0.10
Case 2	-7.68	3.32	0.48	-27.7	3.39	-0.09
Case 3	1.39	12.1	0.77	-25.1	3.34	0.16

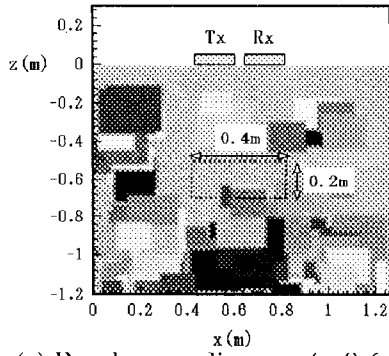

(a) Random medium $\epsilon_r(x, 0.64, z)$

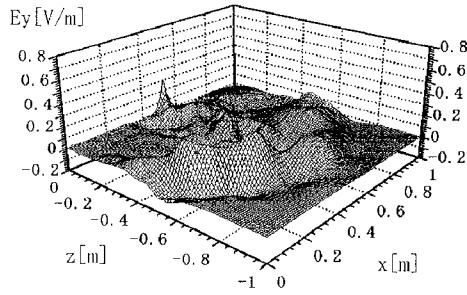

(b) Electric field on $y=0.64\text{m}$ at 6ns

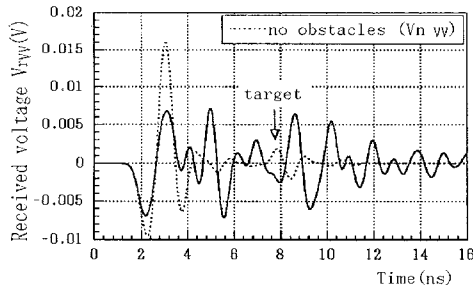

(c) Received signal at copolarization

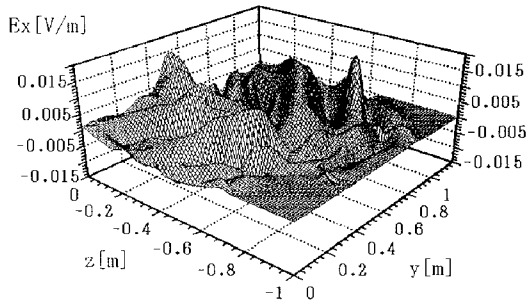

(d) Electric field on $x=0.64\text{m}$ at 6ns

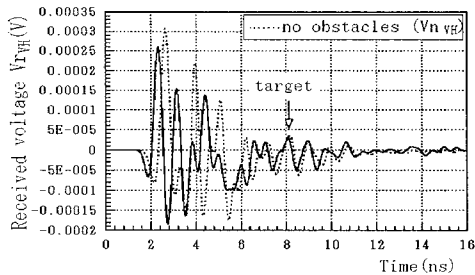

(e) Received signal at crosspolarization

Fig. 5 Results of FDTD simulation in Case 2.

$$(l_g = 0.10 \text{ m}, \mu_{\Delta\epsilon} = 0.20)$$

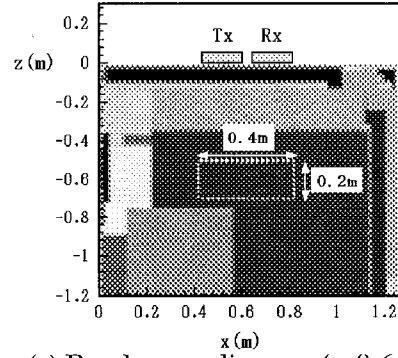

(a) Random medium $\epsilon_r(x, 0.64, z)$

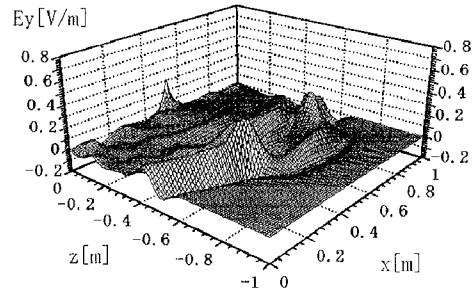

(b) Electric field on $y=0.64\text{m}$ at 6ns

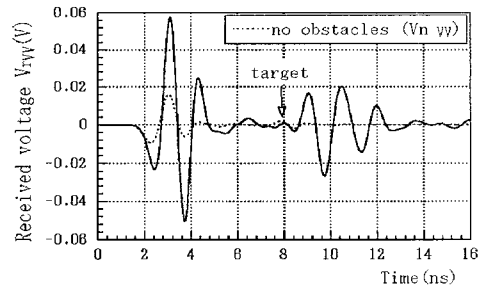

(c) Received signal at copolarization

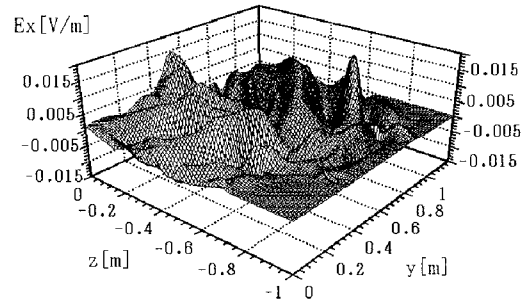

(d) Electric field on $x=0.64\text{m}$ at 6ns

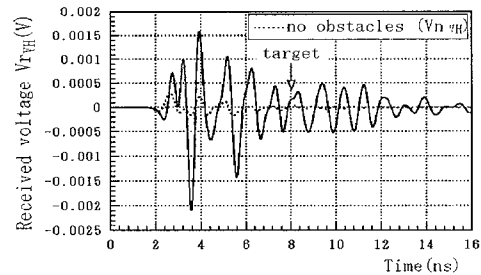

(e) Received signal at crosspolarization

Fig. 6 Results of FDTD simulation in Case 3.

$$(l_g = 0.20 \text{ m}, \mu_{\Delta\epsilon} = 1.90)$$