

Beam Switched Antenna Using Inverted F Antenna for Mobile Terminal

¹Shun Yonezawa, ¹Rohani Bakar, ¹Hiroyuki Arai, ²Amane Miura, ²Hiroyuki Tsuji

¹Dept. of Electrical and Computer Engineering

Graduate School of Engineering, Yokohama National University
79-5, Tokiwadai, Hodogaya-ku, Yokohama, Kanagawa, 240-8501 Japan
yonezawa-shun-fm@ynu.jp

²4-2-1, Nukuikitamachi, Koganei-cho, Tokyo-to, NICT

Abstract – This paper presents a beam switched antenna using inverted F antenna for mobile terminal application in satellite communication. The antenna produces unidirectional radiation patterns in yz-plane which can be switched in two directions using a simple feeding circuit. This paper discusses the prototype antenna as well as the feeding circuit which is fabricated to demonstrate the switching of the beam patterns in vertical plane.

Index Terms — Inverted F antenna, beam switched antenna, super directivity array, mobile terminal.

1. Introduction

The spread of the portable terminals for wireless mobile satellite communication entails for miniaturization design with high gain characteristic antenna. In mobile satellite communication, the line margin in the link budget of voice communication by a portable terminal is small with 3.4 dB for forward link and 1.1 dB for return link [1]. Hence, the antenna gain is crucial and needs to be considered in designing the antenna. Furthermore, the exposure of the radio waves radiation to human body can be reduced with unidirectional radiating antenna instead of conventional omni directional antenna. In this paper, we propose an antenna satisfying these requirements where a single directivity with switching property is obtained with super directivity effect and small inter-element spacing. A printed half-dipole antenna having super directivity effect is reported in [2]. In [3], an inverted F antenna mounted on broad base plate produces a super gain effect and can switch the directivity. This paper proposes a beam switched antenna using inverted F antenna capable of switched, unidirectional directional radiation pattern perpendicular to the antenna element. The effectiveness of the antenna is demonstrated in both simulation and measurement results.

2. Antenna design

The proposed antenna is intended for portable terminal of mobile satellite communication operating at frequency 2 GHz. The antenna will be fixed on top of the mobile terminal and the objective is to increase the gain of the radiation pattern. Fig. 1 shows the geometry of the proposed antenna consisting of two parts, the ground plane (GP) and the

antenna pack. Two inverted F elements is placed 0.05λ from each other and each element can be excited independently making the other as parasitic element. The excitation produces a unidirectional beam pattern due to the strong coupling between the elements. The impact of the GP is shown in current distribution results in Fig. 2. Three conditions are investigated where in (a), the elements are directly connected to the GP while in (b), a conductor is connecting the antenna pack and the GP. In (c), the current distribution flowing from the GP is totally cut off when an inductor is inserted in the conductor offering the optimized structure.

The directivity of the pattern is shown in Fig. 3 where the black line and red line corresponds to the feeding port 1 and 2, respectively in Fig. 1. The patterns show that the radiation in the opposite direction is reduced while the radiation angle is increased producing a high gain directivity at angle 60° .

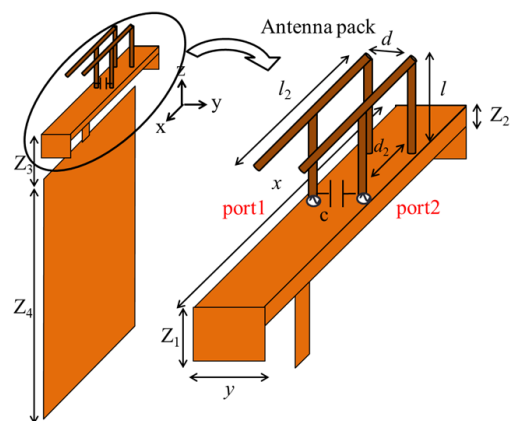

Fig. 1. The geometry of the proposed antenna.

$x=0.46\lambda, y=0.067\lambda, w=0.007\lambda, d=0.05\lambda, d_2=0.12\lambda, l=0.11\lambda, l_2=0.27\lambda, Z=0.067\lambda, Z_2=0.013\lambda, Z_3=0.067\lambda, Z=0.733\lambda, C=10[\text{pF}]$

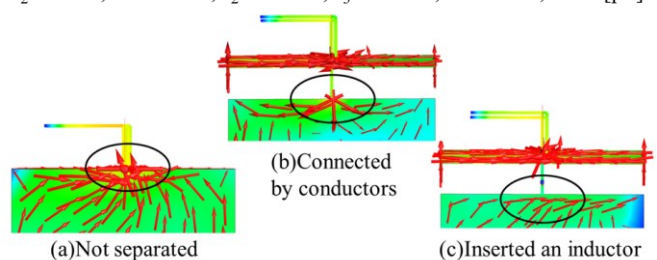

Fig. 2. Current distribution in 3 conditions.

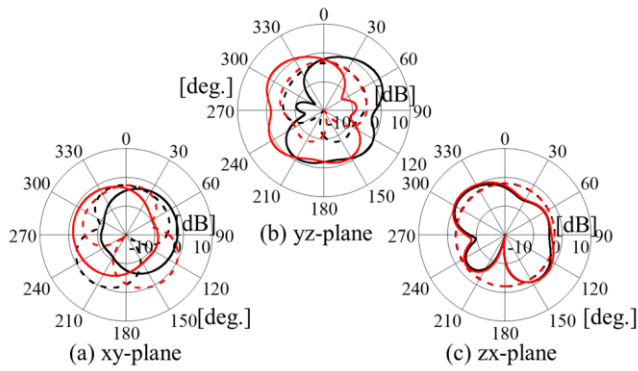

Fig. 3. Radiation patterns at 2 GHz.

— Principle --- Cross — Port 1 — Port 2

The antenna is fed using the feeding circuit shown in Fig. 4. The proposed circuit is made of a substrate with dielectric constant, $\epsilon_r=4$ and diodes that can be switched on and off providing one open port and one short port. Therefore, the pattern can be switched in two directions in yz-plane. The reflection characteristics are shown in the S-parameter results.

3. Experiment result

The proposed antenna together with the feeding circuit is fabricated where the feeding circuit is grounded to the GP. The size of the GP is optimized to the size of a typical smartphone. Fig. 5 shows the S-parameter results where the resonance points are shifted from the simulation results for both ports. The reflection characteristics are confirmed below -10 dB at the design frequency.

The radiation pattern in yz-plane is shown in Fig. 6 with the black and red line represents port 1 and 2, respectively. The directivity is confirmed in agreement with the simulation result with the half power beamwidth of approximately 20 MHz. In addition, the gain is increased 1 dB as compared to the inversed F antenna in the previous research. For the future work, the half power beamwidth and cross-polarized wave of the suppression will be considered.

4. Conclusion

This paper presents the beam switched antenna for mobile terminal application using inverted F antenna. A method of cancelling the current distribution flowing from the GP is also proposed by inserting the inductor in the conductor. Furthermore, a feeding circuit with switching capability is designed. The antenna has a high gain, unidirectional patterns in yz-plane that can be switched in two directions.

References

- [1] T. Minowa et al., "Satellite/terrestrial integrated mobile communication system for nation's security and safety," *IEICE Trans.* vol. J91-B, no. 12, pp. 1629-1640, 2008.
- [2] H. Abdullah and A. Sharaiha, "Design of small parasitic loaded superdirective end-fire antenna arrays," *IEEE Trans on Antennas and Propagation*, vol. 63, no 12, pp. 5456-5464, Dec. 2015
- [3] H. Nakamura and H. Arai, "A study of super gain effect of inverted F antenna array," *2014 IEICE Society Conf.*, B-1-118, Sep. 2014.

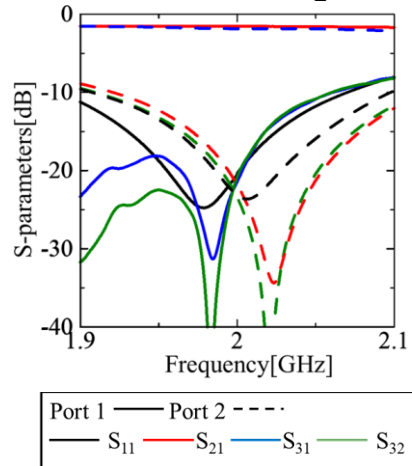
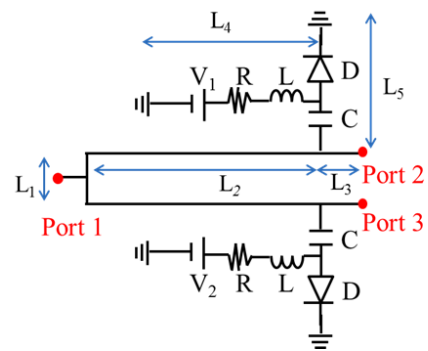

Fig. 4. The feeding circuit

$C=100[\text{pF}], L=22[\text{nH}], R=680[\Omega], L_1=0.16\lambda,$
 $L_2=0.31\lambda, L_3=0.05\lambda, L_4=0.11\lambda, L_5=0.11\lambda[\text{mm}]$

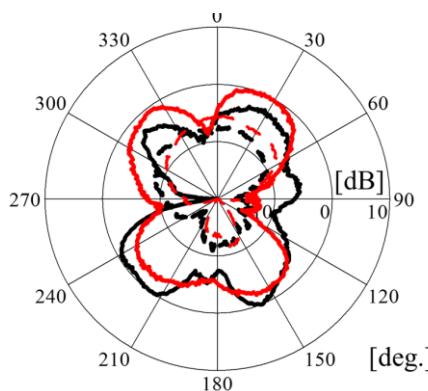
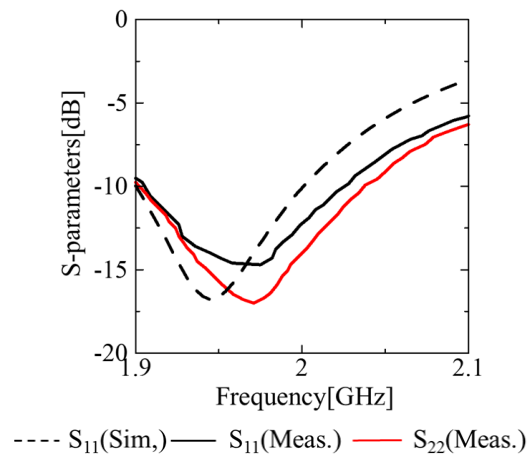

Fig. 6. Radiation pattern (yz-plane)

— Principle --- Cross — Port 1 — Port 2